

Analog to Digital (A/D) Conversion Techniques

Successive Approximation

Compare against a series of reference voltages that are generated by a D/A.

Fairly slow (hundreds of microseconds)

Requires sample and hold (S/H)

A simple analogy for this (Thanks Bryan!) is to think of the old number guessing game:

Pick a number between 1 and 32 – (19)

Is it less than 16 (32/2) No (1) ; the answer is NO; keep the 16

Is it less than 24 (16+8) Yes (0) ;the answer is YES; discard the 8

Is it less than 20 (16+4) Yes (0) ;the answer is YES; discard the 4

Is it less than 18 (16+2) No (1) ; the answer is NO; keep the 18

Is it less than 19 (18+1) No (1) ; the answer is NO; keep the 19

10011 in binary is 19 in decimal

The new reference value (guess) is calculated each time by dividing the remaining distance by two and adding to the previous best guess. If the guess is correct then it is subtracted off and the next value is added to the previous best guess.

Integration (dual-slope)

The converter charges a capacitor (integrates current) for a fixed time using the input voltage signal. It then discharges the capacitor until it is completely discharged.

(comparator). The ratio between the charge and discharge times is dependent on the signal voltage.

This technique works well because it depends on counting timer ticks, which is easy in a computing environment, and a single comparator to determine when the voltage has reached zero. The weakness of it is that it takes a relatively long time. The resolution is dependent on the number of ticks counted therefore the longer the cycle the better the resolution. Integration A/D is frequently used on low-cost computing devices and can take tens of milliseconds to make a measurement.

Dual slope: By first charging and then discharging the capacitor the effects of clock drift are eliminated. The timing of the charge slope is compared to the timing of the discharge slope. This process will be completed within tens of milliseconds, not enough time for the clock to drift.

Dual slope converters are slower than successive approximation ones but achieve better resolution.

Flash

Uses many comparators to compare against a set of reference voltages.

A comparator is set up for every single voltage that has a binary value. EG if you want a 8 bit binary output you set up $2^8 - 1 = 255$ comparators, each with their own reference, a 16 bit converter would require 65535 comparators. The binary output is the ADDRESS of the highest numbered comparator that is triggered by the signal voltage.

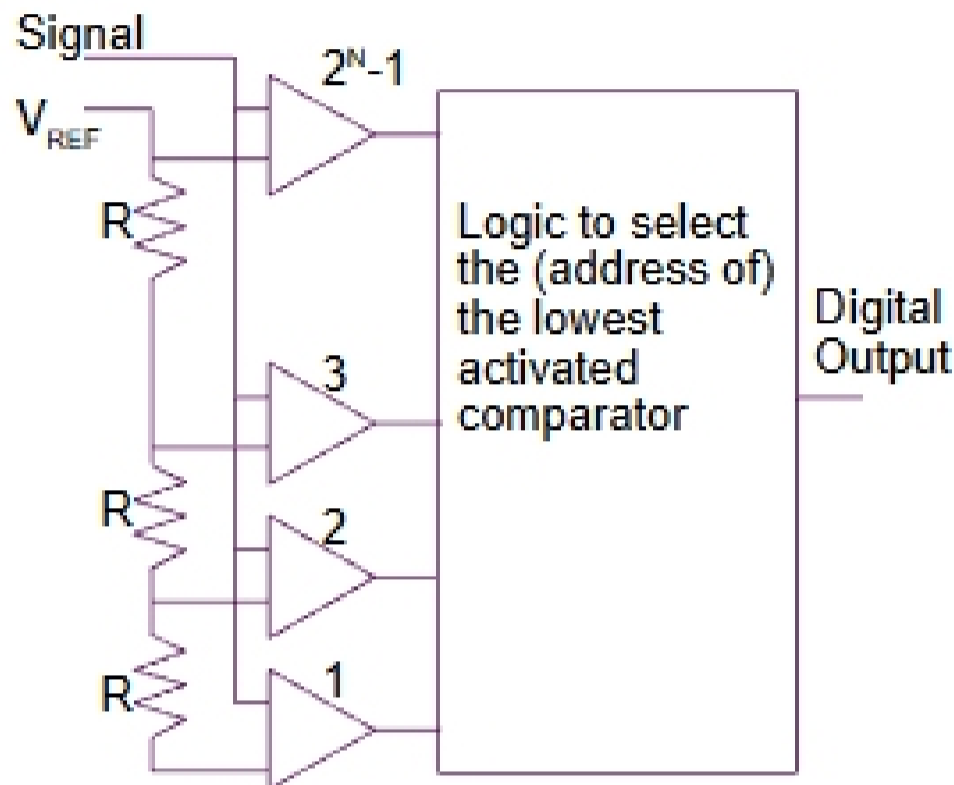

Flash converters operate very fast, in microseconds or even nanoseconds, which gives very high sampling rates. They require large numbers of comparators which must each be precisely set up. The voltage reference is divided down the chain of resistors (which must be accurate) and each comparator receives the original signal and compares it against its reference. The highest comparator that matches is the value of the signal. The accuracy of the converter depends entirely upon the accuracy of the single comparator that is active. In other words the worst case accuracy is the accuracy of the single worst comparator.

Modern flash comparators are made on a single integrated circuit. By doing it on a single circuit the values of the resistors can be precisely controlled and the comparators can be matched.

Flash A/D converters are easily the fastest converters available but cannot achieve high resolution due to the number of comparators required.

$\Sigma\Delta$ (Sigma Delta)

This is a form of tracking converter. A sigma-delta A/D converter compares the signal at each step with its value at the previous step. If the signal is greater than the current reference value the reference value is *increased* a fixed amount and the operation is repeated. If the signal is less than the reference value the reference is decreased a fixed

amount and the operation is repeated. The wave is recorded as a sequence of ones and zeros. A one is recorded every time the wave is increased and a zero every time it is decreased.

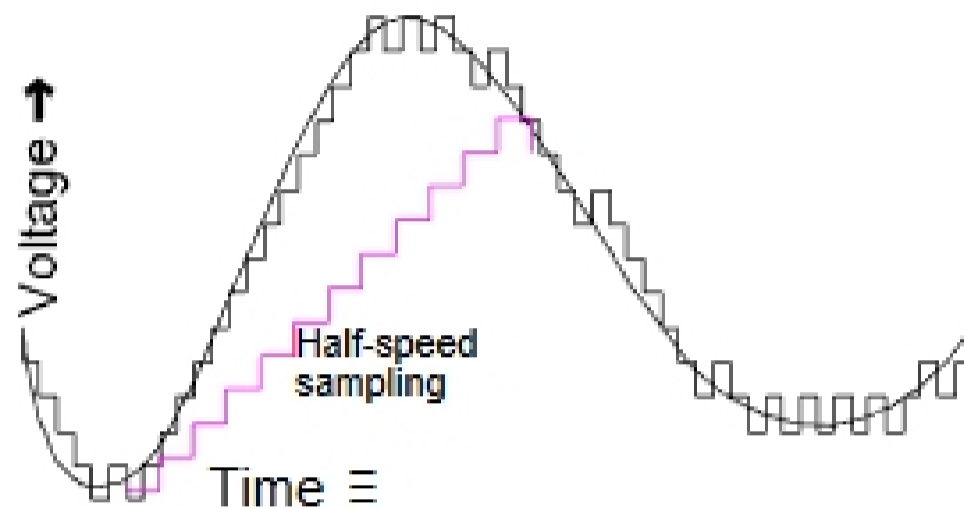

The binary sequence for the above wave starts 0 0 0 0 0 1 0 1 1 1 ...

Using this approach it is necessary to sample frequently to accurately model the waveform. The second (mauve) line shows the poor modeling of the rising wave if the sampling rate is halved. If the step height were doubled the step function would again be able to follow the wave, but much more coarsely, i.e. the frequency response would be better but the resolution would be poorer.

Because just a single stream of bits is recorded and because it is possible to trade off between sampling rate and resolution, $\Sigma\Delta$ conversion is sometimes called single-bit conversion. Marketing departments of CD players often use this title. It is confusing at best.

Sigma-delta converters are often used for high frequency DSP work. Traditionally they have not been used for ordinary industrial instrumentation, but are appearing in more and more devices.

Multiplexing

Most A/D converters operate in milliseconds or faster. Many industrial applications only require signals to be read on a scale of seconds. Since A/D converters are fairly complex devices it is possible to save money by combining a single converter with a multiplexer to achieve a multi-channel converter. Speed of conversion is traded for multiple channels.