

UNIVERSITY OF CALIFORNIA AT BERKELEY
College of Engineering
Department of Electrical Engineering and Computer Science

R.W. Brodersen
Jianhui Zhang

Homework #9
(Due 12/01/03)

EECS 140
Fall 2003

1. In the circuit of Fig.1, ignore all device capacitance. Include only C_{GS1} , C_{GS3} , and C_o in your calculations. Take $\lambda_n = 0.01$ and all $V_{DSAT} = 200\text{mV}$. Also take $C_{GS1} = C_{GS2} = 1\text{pF}$ and $C_o = 100\text{nF}$. Assume M1-3 are active.

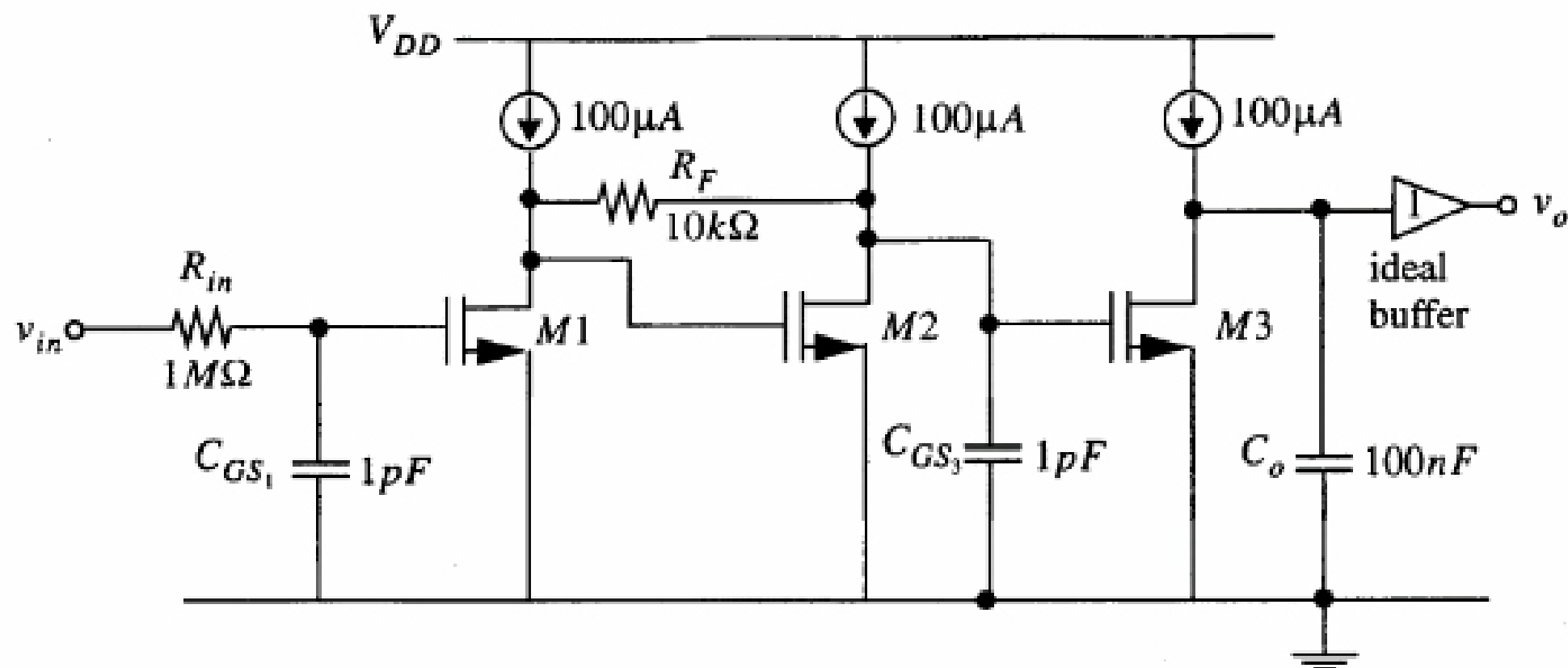

Fig. 1

- Determine the poles of the amplifier of Fig.1 if $R_F = \infty$, i.e. if R_F is removed.
- If the amplifier of Fig.1 with $R_F = \infty$ was connected in a unity gain connection, i.e. connect V_{in} to V_o , would the circuit be stable? Explain.
- Determine the poles of the amplifier with $R_F = 10\text{k}\Omega$.
- Determine the low frequency gain of the amplifier if $R_F = 10\text{k}\Omega$.
- Estimate the frequency of the lowest pole in a unity gain feedback connection with $R_F = 10\text{k}\Omega$, i.e. connect V_{in} to V_o .

2.

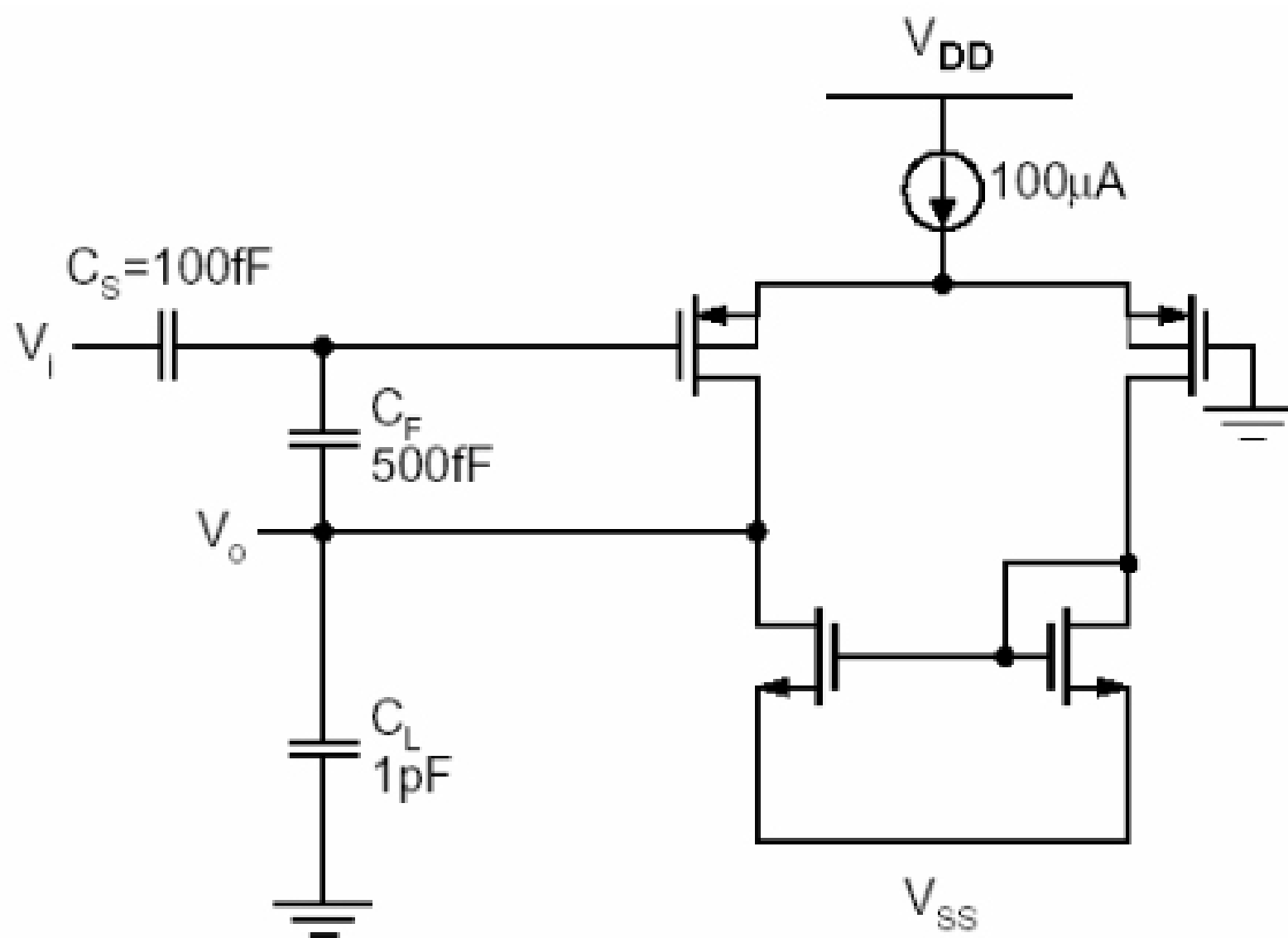

Fig. 2

In the circuit shown in Fig.2, estimate the settling time for 0.1% error for an input step amplitude $V_i = 2\text{V}$ into the amplifier below. Neglect all capacitors except the three that are explicitly shown. $V_{DSAT} = 200\text{mV}$ (all device). Assume all devices in saturation, amplifier is stable and $\lambda_n = \lambda_p = 0.1$.