

The University of Iowa
Department of Civil & Environmental Engineering
53:030 Soil Mechanics, Fall Semester 2003
Lab Experiment No. 11:
Shear Strength of Sand via Direct Shear Tests

A. Objective

In this laboratory experiment, the shear strength of both loose and dense sand samples are measured using a displacement-controlled direct shear apparatus. The horizontal displacement δ_h , the vertical displacement δ_v and the shear force F_n will be measured using L.V.D.T. transducers and a Labview® direct shear program.

B. Experimental Procedure

The experimental setup and procedure for this displacement-controlled test is standard and can be found in many references, for example in *Experimental Soil Mechanics* by J.P. Bardet, which is on reserve for this course in the Engineering Library. In the lab, your instructor will explain the direct shear apparatus and demonstrate the experimental procedure. A description of the direct shear test as a means of measuring the shear strength behavior of soils can also be found in Section 11.4 of your textbook.

Upon becoming familiar with the direct shear apparatus, you will measure the shear strength behavior of both loose and dense sands. For both types of sand, the specimens will be sheared to failure along a fixed plane. For each type of sand (loose and dense):

- the shear test will be repeated three times with a different normal stress acting on the shear plane each time ($\sigma_n \cong 100\text{kPa}$, 200kPa , and 400kPa)
 - for each trial, compute the initial dry density of sand in the apparatus, and the corresponding initial void ratio e_o .
- 1) Prepare the shear box: Assemble the shear box by connecting the lower half and the upper half with the pair of alignment screws provided. Place the lower metallic pressure pad into the assembled shear box (via the top), and then place one porous plate on top of the lower metallic pressure pad.
 - 2) Sample preparation:
 - a) Loose: for a loose sand specimen, simply pour the sand into the shear box until the desired thickness is attained. Level the top part of the sand specimen so the porous plate and the upper pressure pad, when they're applied, will rest horizontally.
 - b) Dense: for a dense sand specimen, apply the sand in 3 layers, and after each layer use the compaction tool to compress the layer (ask the T.A. for the compaction tool).

For both the loose and dense soil samples, the procedure for measuring the mass will be identical. Fill an evaporating dish with the soil FI-6, then measure and record the mass M_1 . Dispense enough soil into the shear box to give the specimen a height of 25mm, or fill the shear box until the small holes on the inside of the shear box are just barely covered. Measure the new mass M_2 , and subtract it from M_1 to acquire the mass of the specimen M_{sand} . To obtain the actual height of the specimen, place a porous plate on top of the flat surface of the specimen, and

measure the distance (h) from the top of the shear box to the top of the porous plate (refer to figure below). Then, subtract (h) from H_{fixed} (3.03 cm) to determine the height of the sample H_{sand} .

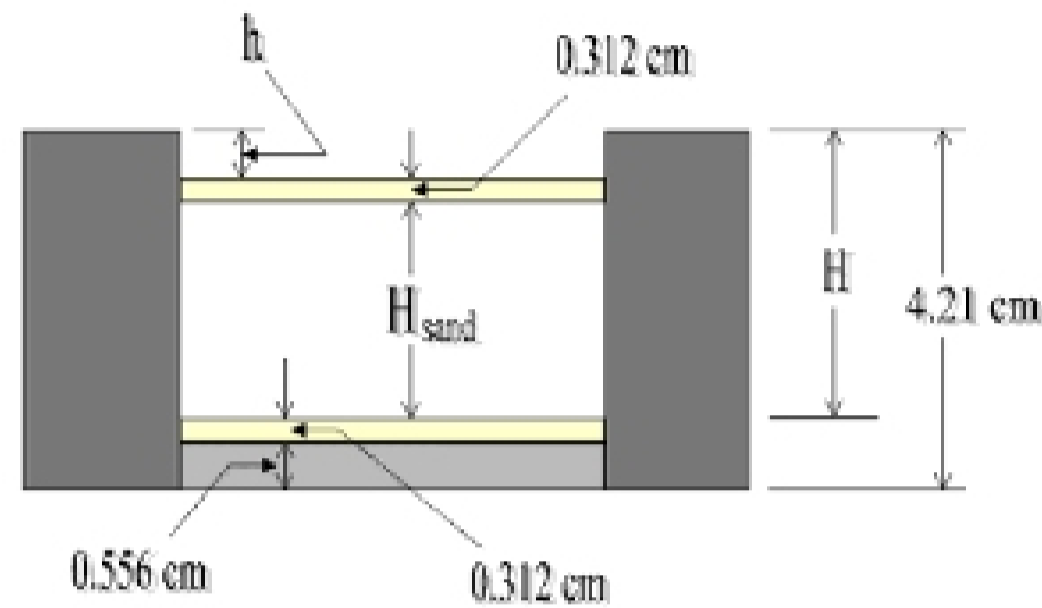

Once the mass and the height of the soil sample have been determined, the void ratio e_o can be easily computed using the following equations.

$$V_{\text{sand}} = H_{\text{sand}} * A \qquad \rho_{\text{sand}} = \frac{M_{\text{sand}}}{V_{\text{sand}}} = \frac{\rho_w * G_s}{1 + e_o}$$

where $A = 31.67 \text{ cm}^2$

- 3) Insert the shear box: Place the shear box into the carriage, so that the driving lugs, on the top half of the shear box, are connected to the front part of the swan neck. Next, place the upper pressure pad into the shear box. Then use the locking screws, on the outside of the carriage, to secure the shear box. Once the shear box is secured, take the alignment screws out and screw in the pair of separator screws into the two additional holes provided. Once the two halves of the shear box have been separated, remove the pair of separator screws from the top of the shear box (**Make sure you take both pairs of screws out before going further!!**). Return the yoke to its vertical position and secure it with the bolt (it is not necessary to fully secure the yoke, just enough to hold it in a vertical position).
- 4) Applying a normal stress: First, crank the jacking handle so when the weights are added, the lever loading arm is supported by the jacking handle. The amount of mass required to achieve the three different normal stresses, can be determined by the following equations and diagram;

$$W(\text{N}) = M(\text{kg}) * g(\text{m/s}^2) \qquad W(\text{N}) = \frac{\sigma_n(\text{kPa}) * A(\text{m}^2)}{f_m}, \quad \text{where } f_m = \frac{L}{x} = 10$$

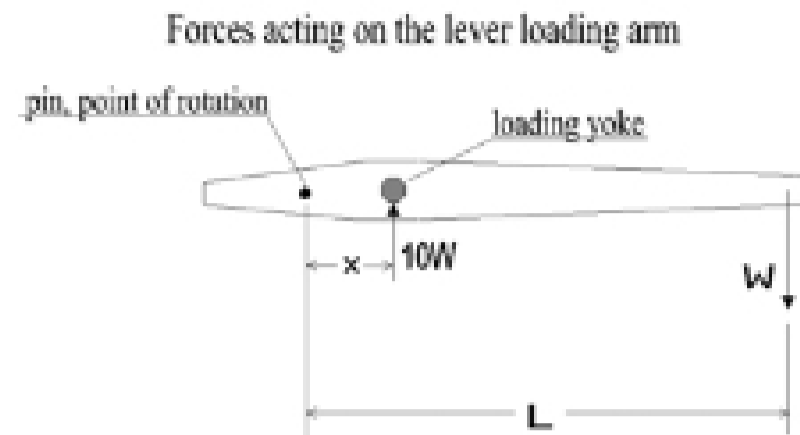

Setting the two equations equal to each other and solving for the mass (M) yields the following equation for determining the amount of mass of a given normal stresses;

$$M = \frac{\sigma_n * A}{g * f_m} \quad \text{kg.}$$

To apply the load to the specimen, slowly wind the jacking handle down so that the load will be transferred to the sample.

- 5) Proving Ring: The proving ring will have a stiffness factor measured in N/mm, and the transducer will be fastened on the inside of the proving ring and will measure the displacement in Volts/mm. Dividing the stiffness of the proving ring (N/mm) by the transducer reading (Volts/mm) will produce a graph in Labview. The values of the graph (N/Volts) are then divided by the area of the shear box, and the result will yield a value for shear force.
- 6) Starting the Direct Shear Apparatus: Turn the machine on using the on/off switch located on the back of the apparatus. Wait a couple of seconds until the display shows:

‘(MANUAL) = STOP = x.xxxxx mm/min’
 ‘[MODE] / Enter Speed #.##### mm/min’

First, set the datum position by pressing the [Mode] key until the display reads:

‘[Enter] [Mode] : Set-0-Datum or [Exit]’

then press the enter key [↵] and the symbol ‘ ’ should appear. Press the [Mode] key until the display shows:

‘[Enter] [Mode] : Manual or [Exit]’

then press the enter key [↵]. After the manual mode has been selected, use the number keypad to enter a speed, and press the enter key [↵] to activate the speed. To start the direct shear apparatus, first start the Labview direct shear program, then press the [Run] key on the display of the direct shear apparatus. To stop the apparatus, simply press the stop key [■]. After the test has been successfully executed, return the carriage back to its initial position by pressing the [] key.

- 7) Data files: The data from each test will be collected via computer. At the end of the week, the data from all tests will be placed on the ECSS system, and you can copy data files from the directory: /usr/ui/class/examples/53:030/lab11 for post-processing and analysis. The sand used in this set of experiments is the same fine-grained uniform soil FI-6 used in Lab #10. Lab Sections 1 and 3 will perform tests on loose sand samples, while Lab Sections 2 and 4 will perform tests on dense sand samples.