

[COILS & THE INDUCTOR -]

This experiment involves looking at inductors, coils and inductor time constants.

PRIMARY and SECONDARY COILS

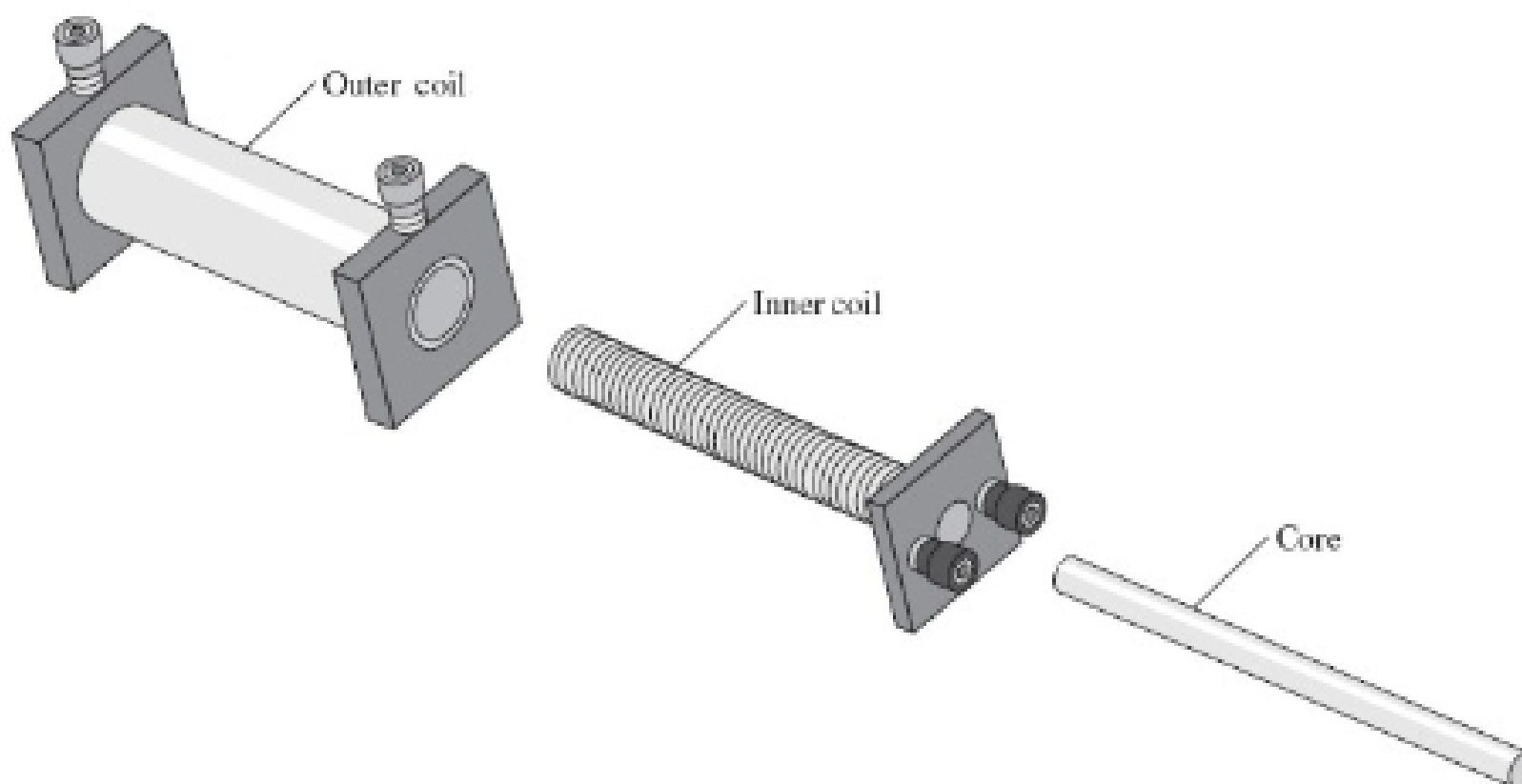

PART I – INTRODUCTORY CONCEPTS

In the last unit we discussed induction (Faraday's Law) and Lenz's Law. We also recognized the importance of Magnetic Flux in these studies. The next step is to study the last electric element that we will encounter in this course: the Inductor. The inductor has a property associated with it that is called "inductance" and in this unit we will study its properties.

The inductance of an inductor is referred to by the letter L which is added to our lexicon that already contains R and C . In this unit we will study the RL circuit (similar to the RC circuit) and then we will plunge into AC circuits and the combination of all three elements.

The symbol for the inductor is:



We begin with some review questions:

1) Consider a U-shaped metal rod with a metal rod touching it, which is free to slide (shown below). A magnetic field is into the page everywhere, as in the diagram.

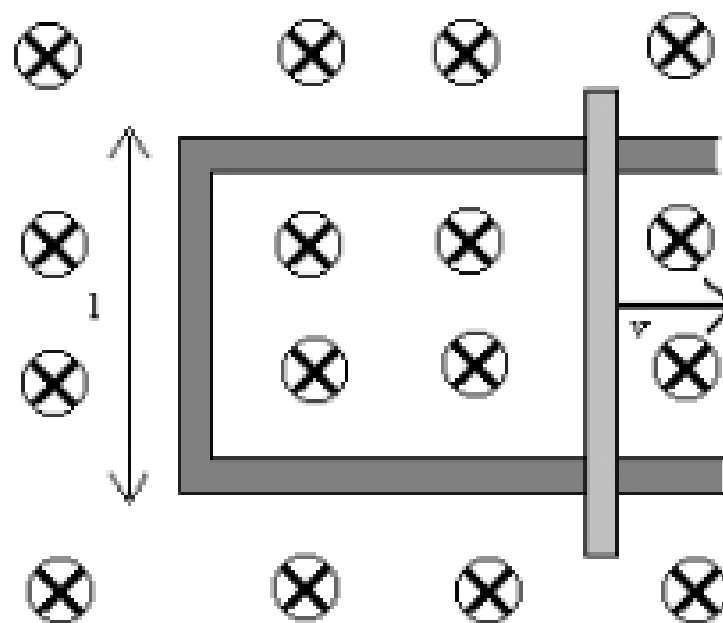

If the rod is moving to the right at a velocity v ,

(i) Would there be a current? Explain. If so, determine the direction of the current.

(ii) Would there be an emf? Explain. If so, calculate the emf in terms of the magnetic field, B , the velocity of the rod, v , and the length l . (i.e. $\frac{d\Phi}{dt}$)

2) Two solenoids 1 and 2 are sufficiently close together that the magnetic field formed in solenoid 1, in the presence of electric current, also penetrates into solenoid 2.

