

Instructor: Robert Dick
 Office: L477 Tech
 Email: dickrp@northwestern.edu
 Phone: 847-467-2298

TA: Neal Oza
 Office: Tech. Inst. L375
 Phone: 847-467-0033
 Email: nealoz@u.northwestern.edu

TT: David Bild
 Office: Tech. Inst. L470
 Phone: 847-401-2083
 Email: d-bild@northwestern.edu

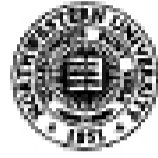

NORTHWESTERN
UNIVERSITY

Flip-flop introduction

- Stores, and outputs, a value
- Puts a special clock signal in charge of timing
- Allows output to change in response to clock transition
- More on this later
 - Timing and sequential circuits

TG and NOT-based memory

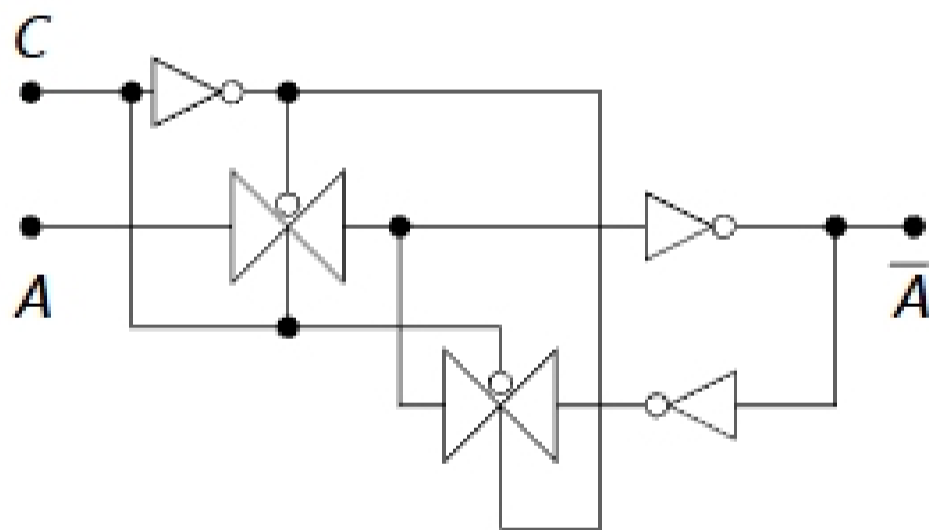

- Can break feedback path to load new value
- However, potential for timing problems

Ring oscillators

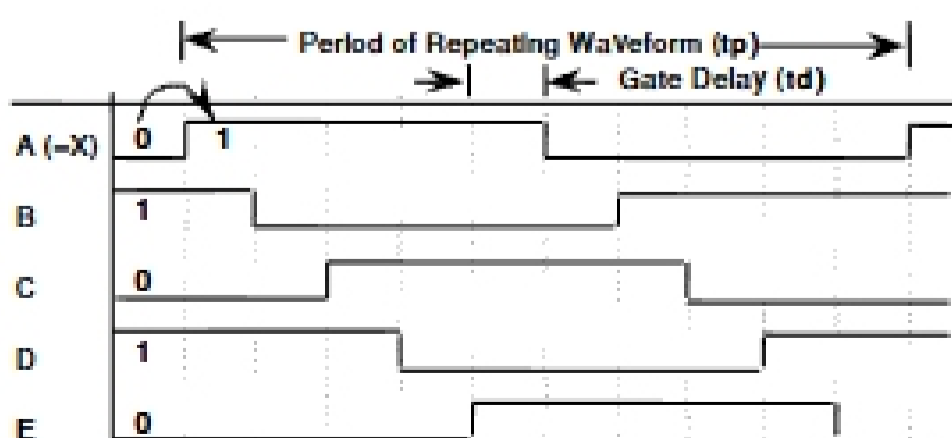

Memory

- Combinational logic outputs a function of inputs, only
- Sequential logic outputs a function of inputs and state
- State is remembered
- Consider a sequential vending machine

Feedback and memory

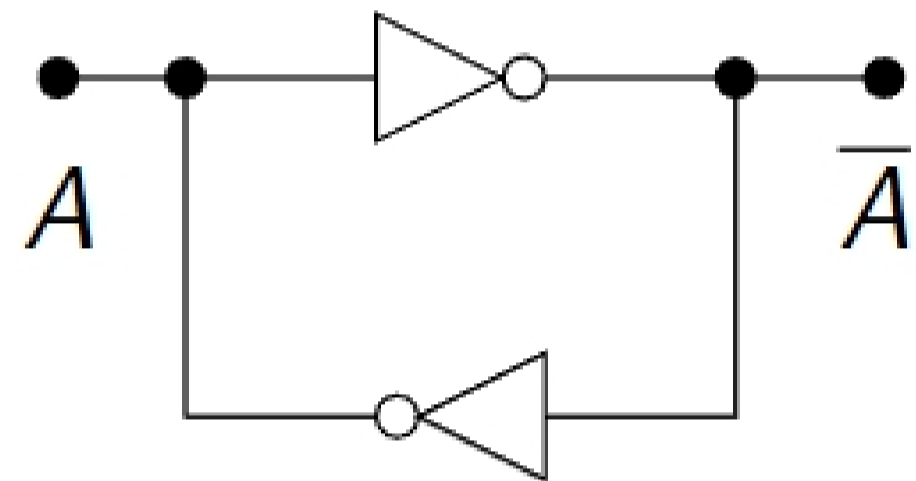

- Feedback is the root of memory
- Can compose a simple loop from NOT gates
- However, there is no way to switch the value

Ring oscillators

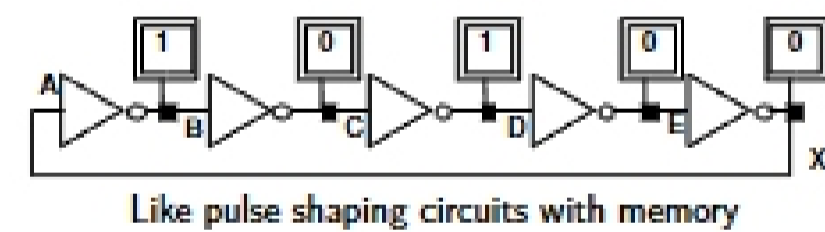

Reset/set latch

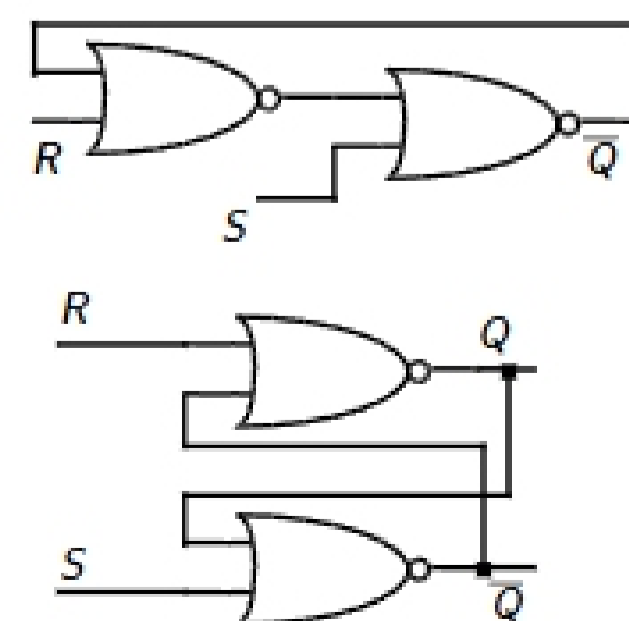

Reset/set timing

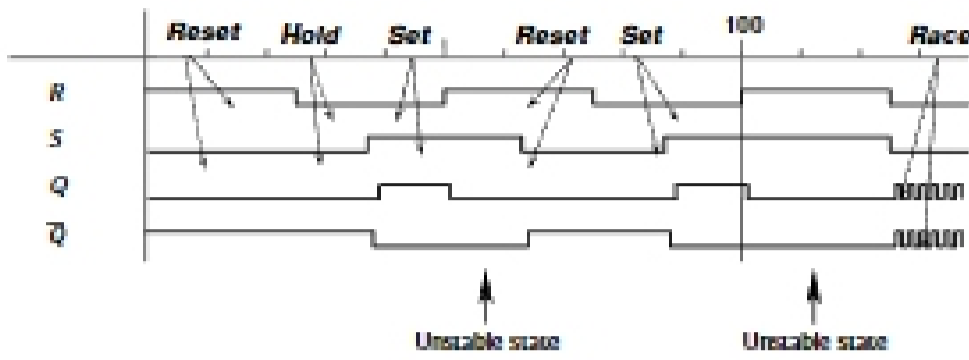

Clocking terms

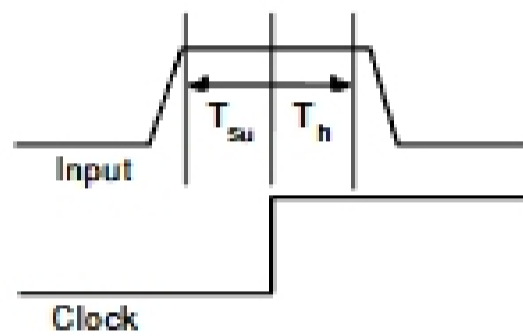

- Clock – Rising edge, falling edge, high level, low level, period
- Setup time: Minimum time before clocking event by which input must be stable (T_{SU})
- Hold time: Minimum time after clocking event for which input must remain stable (T_H)
- Window: From setup time to hold time

Gated RS latch

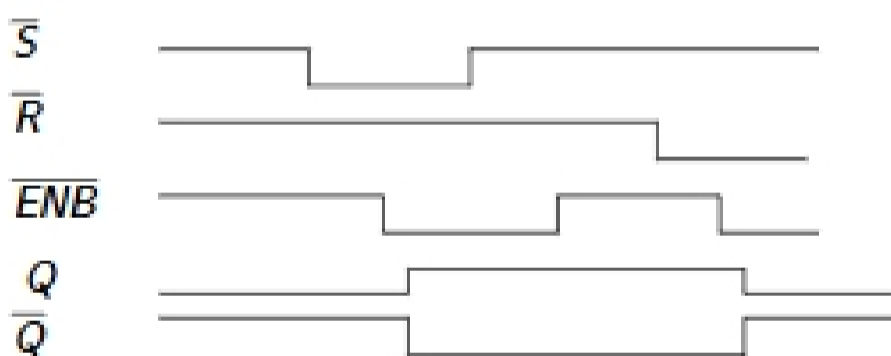

Clocking conventions

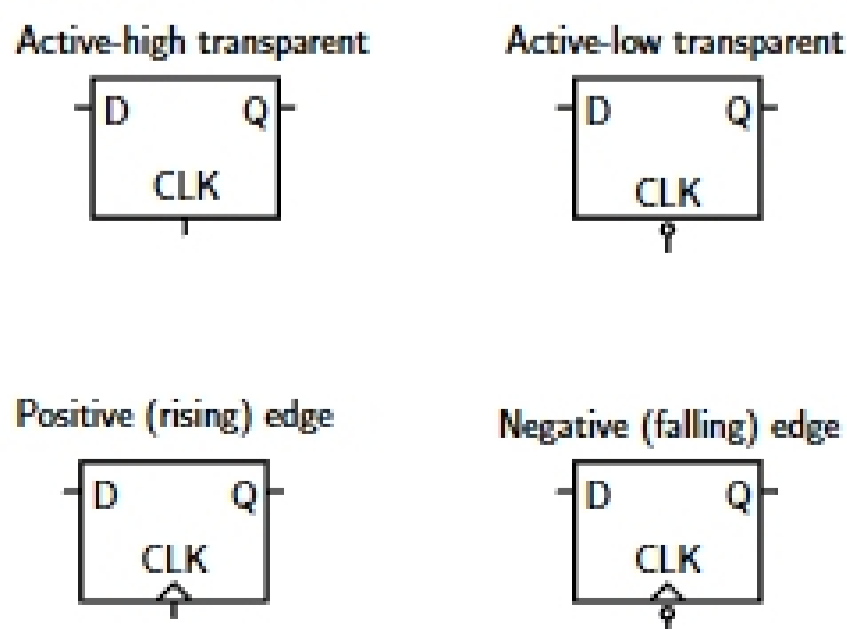

RS latch state diagram

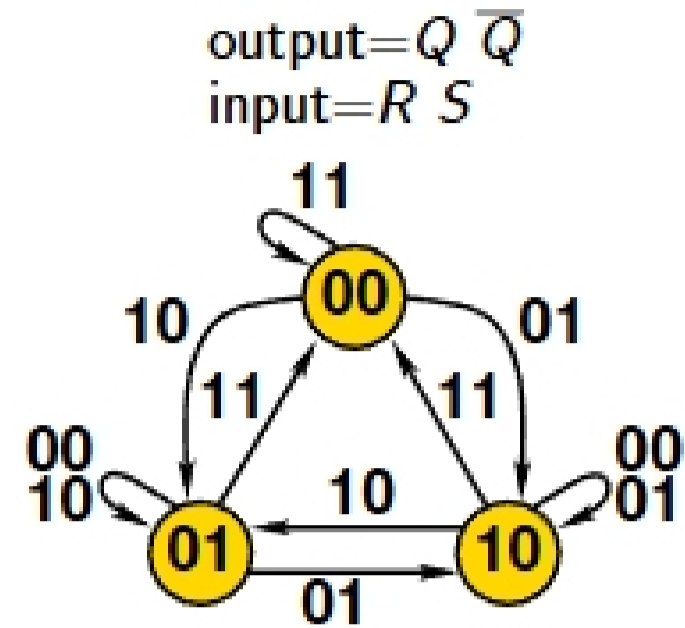

Gated RS latch

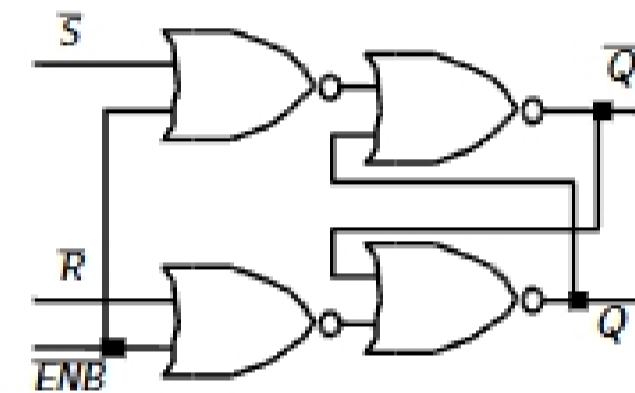

Memory element properties

Type	Inputs sampled	Outputs valid
Unclocked latch	Always	LFT
Level-sensitive latch	Clock high	LFT
Edge-triggered flip-flop	$(T_{SU}$ to T_H) around falling clock edge Clock low-to-high transition $(T_{SU}$ to T_H) around rising clock edge	Delay from rising edge

Timing for edge and level-sensitive latches

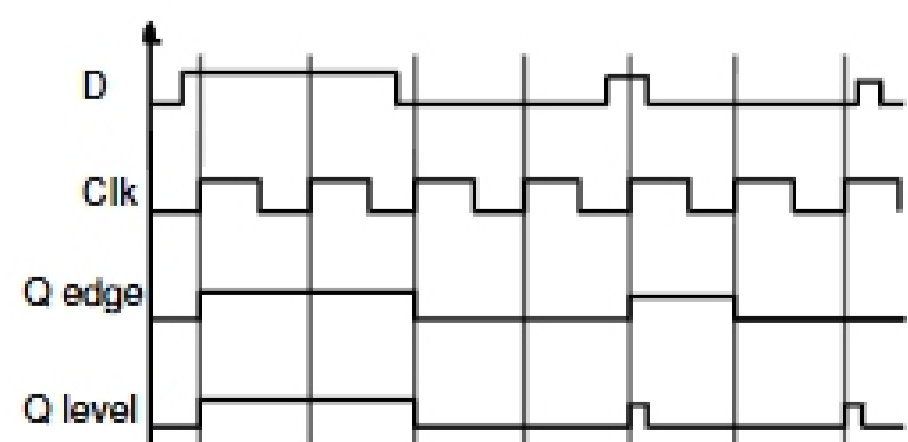

Summary

- Memory
- Latches
- Flip-flops (more on these later)

Computer geek culture reference

Computer security

- PGP
- (Open)SSH
- (Type II) remailers
- Wireshark
- Crack

Reading assignment

- M. Morris Mano and Charles R. Kime. *Logic and Computer Design Fundamentals*. Prentice-Hall, NJ, fourth edition, 2008
- Sections 5.1–5.7
- Sections 6.1–6.4