

**EGR 262**  
**Fundamental Circuits Lab**  
**Presentation for Lab #5**  
**Digital to Analog Conversion**

**Instructor: Paul Gordy**

**Office: H-115**

**Phone: 822-7175**

**Email: [PGordy@tcc.edu](mailto:PGordy@tcc.edu)**

## Communicating with Digital Devices

The MicroStamp11 is a digital device. This means that its inputs and outputs are typically 0V and 5V, corresponding to the binary logic values 0 and 1. As a result, working with digital inputs and outputs is relatively easy.

In Labs #3-4 we used the MicroStamp11 to work with digital inputs/outputs:

- Digital input: button switch (5V when pressed, 0V when not pressed)
- Digital output: 7-segment display controlled (0V – segment on, 5V – segment off).

### Circuit for Labs #3 - 4

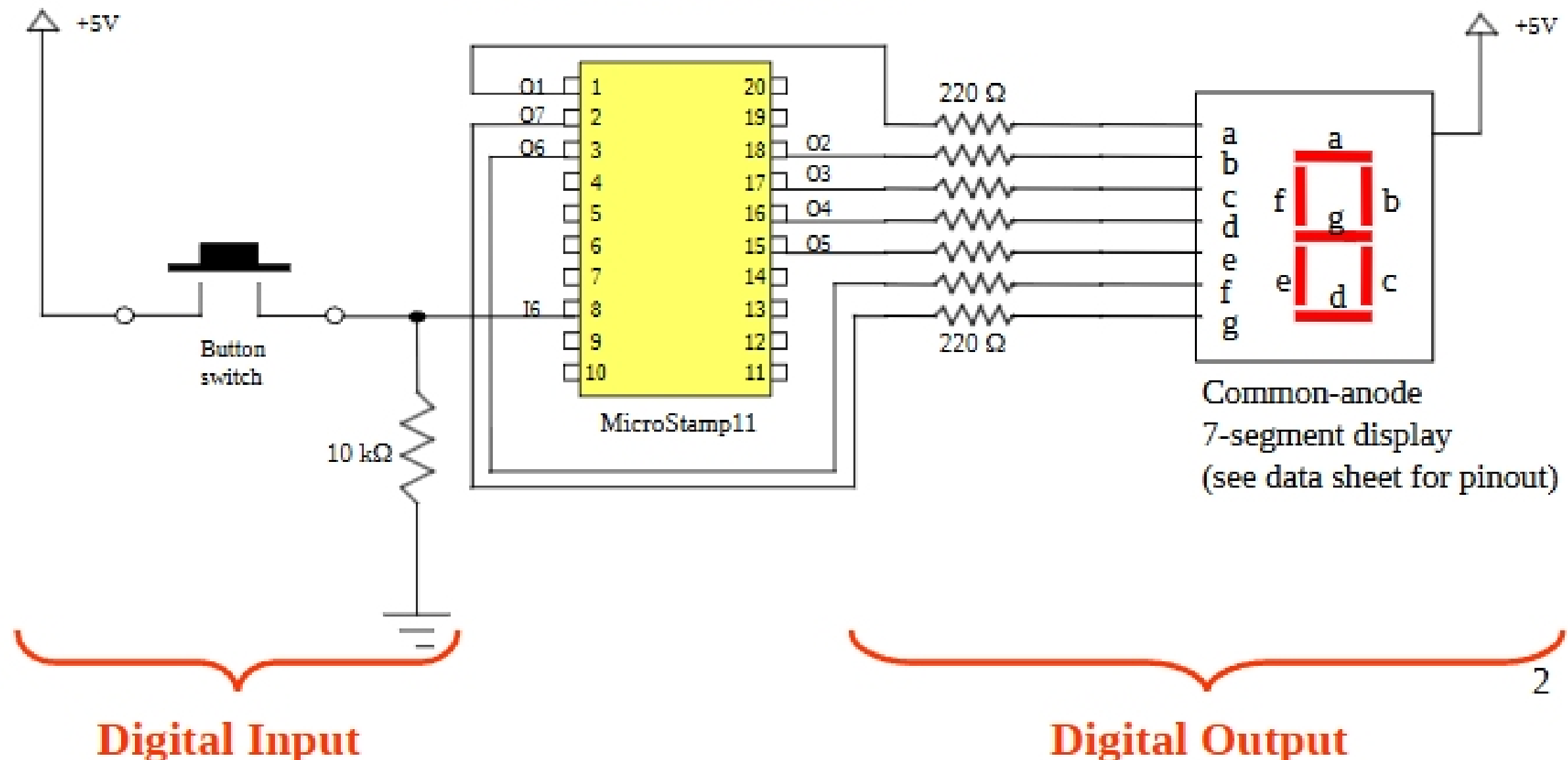

## Communicating with Analog Devices

Using the MicroStamp11 to communicate with analog inputs/outputs is much more difficult than using digital inputs/outputs. Analog devices are devices that can have any amplitude (any voltage level).

### Examples of analog inputs:

- Infrared sensor input – the input voltage varies with the amount of reflected light
- Dimmer switch input – the input voltage varies to indicate the desired output
- Temperature sensor input – the input voltage is related to the temperature
- Read the input voltage from any circuit

### Examples of analog outputs:

- Motor control – vary the motor speed gradually by changing output voltage
- Light intensity control – vary output light intensity gradually by changing output voltage
- Volume control – vary the volume of an alarm by gradually changing output voltage
- Control the output voltage to any circuit