

ECE 2070 - Lecture 6

Equivalent Circuits



Department of Electrical and Computer
Engineering
Clemson University

Overview of DC Electric Circuits

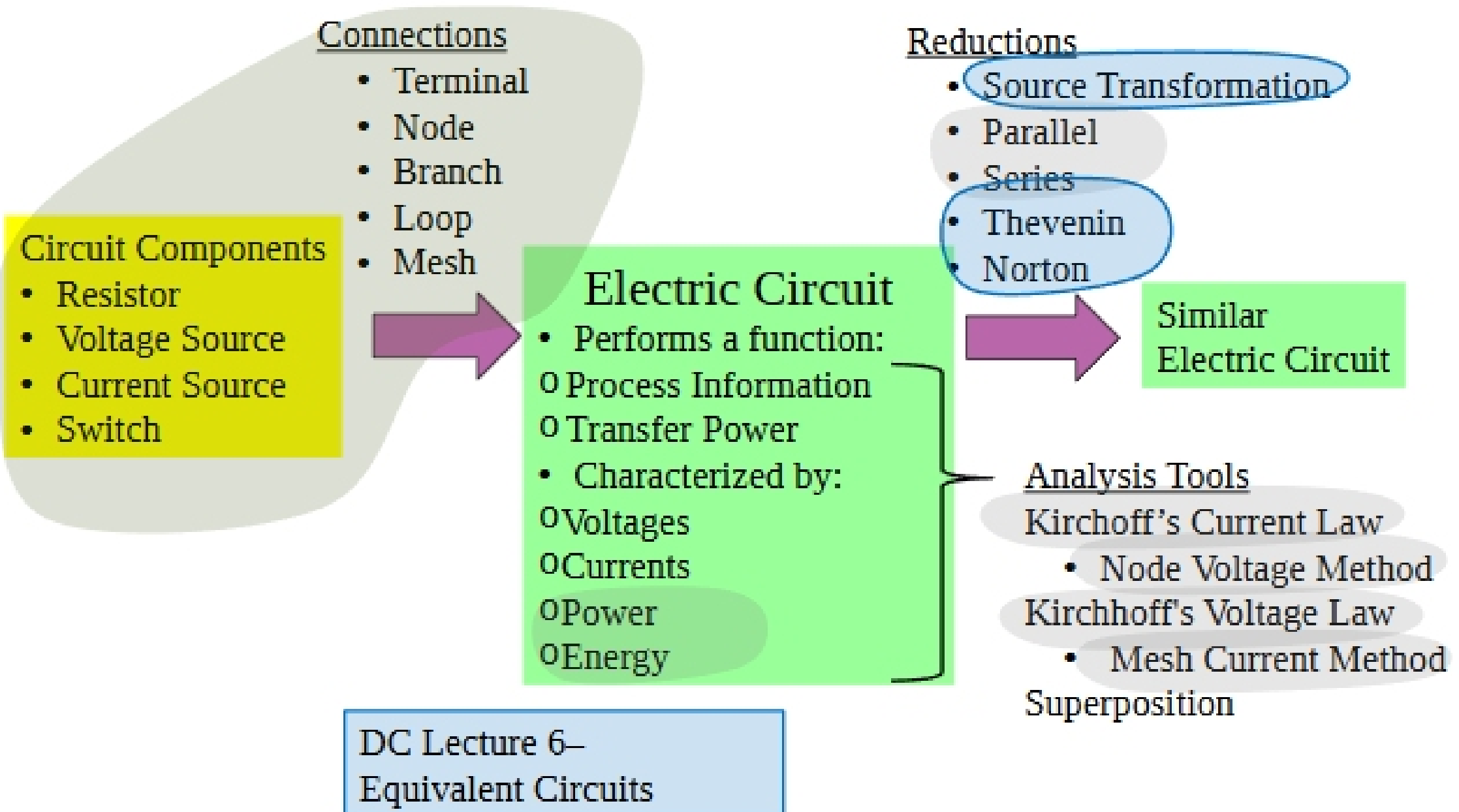



Temperature Sensing - Resistance Temperature Detectors (RTDs)

In a Metal, increasing temperature (T) will increase the resistance (R_T)

$$R_T \approx R_0 + R_0 \alpha T \quad \text{Platinum: } \alpha = +0.00392/^\circ\text{C}, R_0 = 100\Omega \text{ at } T = 0^\circ\text{C}$$

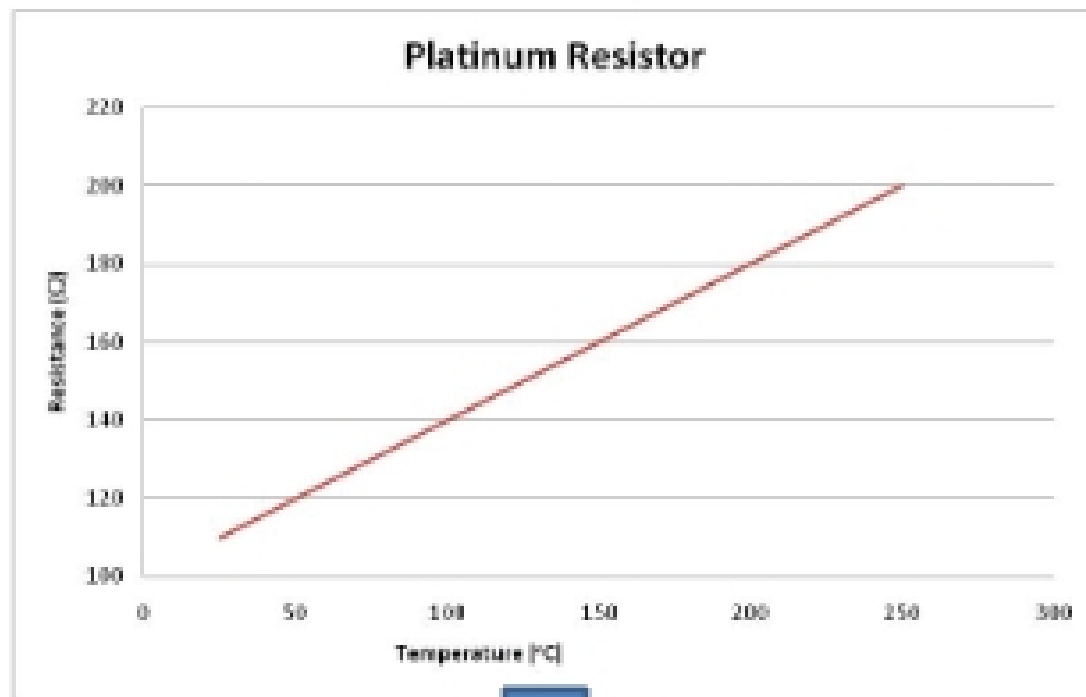

Measure the resistance R then we know T
This is a means of measuring temperature.

Several ways to measure R.

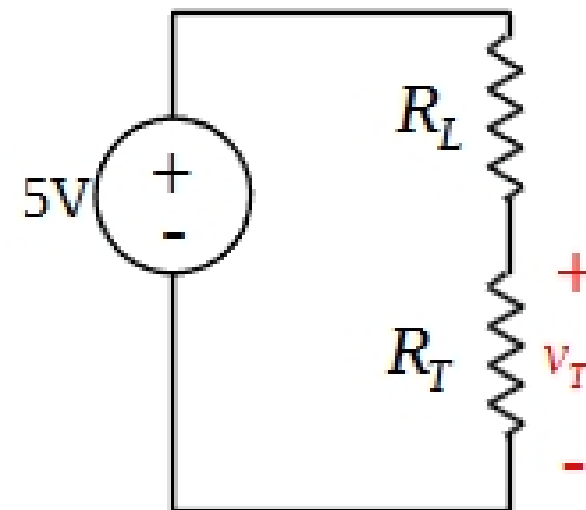

Voltage divider equation:

$$V_T = \frac{R_T}{R_L + R_T} (5V)$$

$$V_T = \frac{R_0 + R_0 \alpha T}{R_L + R_0 + R_0 \alpha T} (5V)$$