

Lab 8: Automatic Nightlight

In this lab, we will again be using the Digilent Analog Discovery DAQ device and your knowledge of MATLAB to design a simple automatic nightlight (turns on and off automatically and adjusts the brightness based on the surrounding light level).

This idea is similar to what your phone or computer may do when it adjusts the brightness of the screen based on whether you are out in the sun or in a dimly lit room. When you are out in the sun, the ambient light level is usually high, which causes the device to increase the brightness of the screen so you can see it better. When you are in a dimly lit room, it can be very difficult to read a screen if it is at full brightness, so the device may set the screen to a lower brightness level. In our situation, we will be doing the opposite: making an LED brighter as the room gets darker.

In order to accomplish these tasks, you will be required to use your knowledge of conditional structures and loops. You will work in groups of three to design and test your system.

A. Building the Circuit

The circuit you must build for this lab is shown below. To construct it, you will need the following items:

- 1x Light Emitting Diode (LED)
- 1x Photocell
- 1x $1\text{k}\Omega$ resistor
- 1x $10\text{k}\Omega$ resistor
- 1x yellow connector wires
- 2x orange connector wires
- 1x black connector wire
- 1x red connector wire

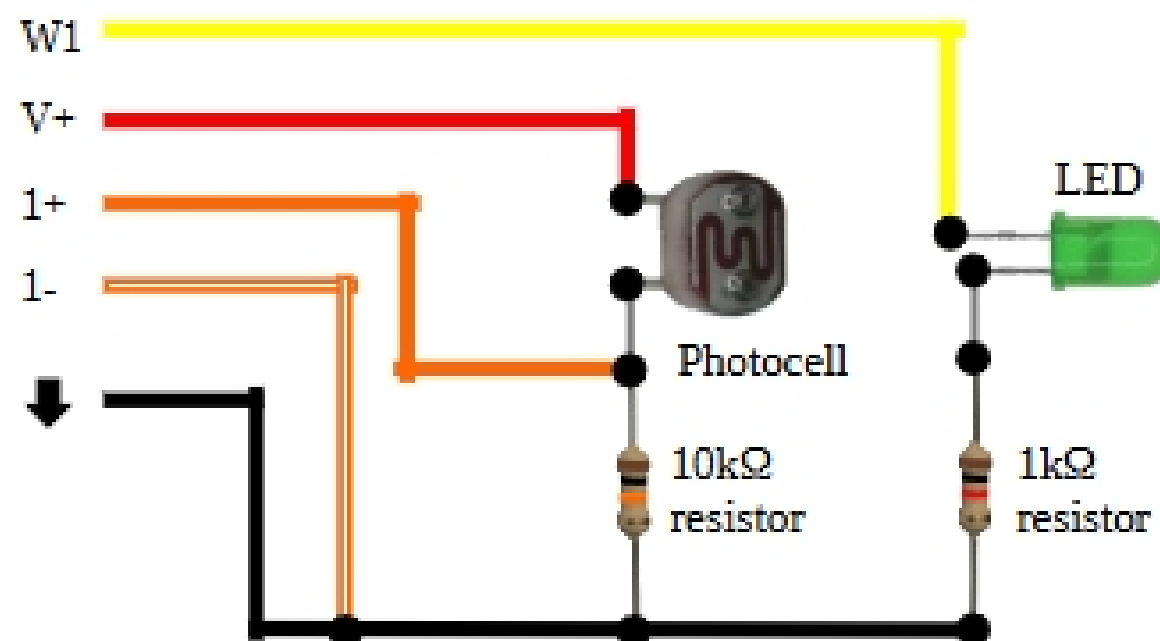

Notes:

- Just like the capacitors we used in lab 5, the LED has a polarity. Connect the longer lead from the LED to the W1 connection and the shorter lead to the connection with the $1\text{k}\Omega$ resistor.

A possible breadboard layout is shown below:

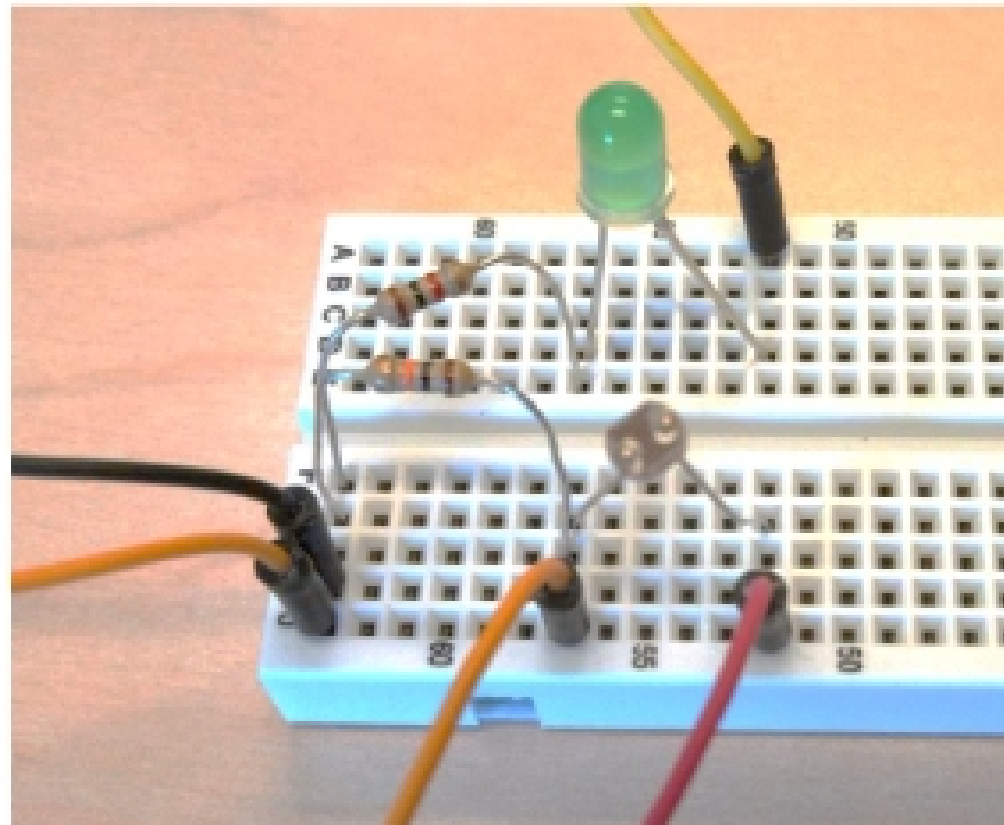

B. Software Check for Digilent DAQ

Note: if you used your computer on Lab 5 and you have not uninstalled any software, you can skip to step 5 to check MATLAB communication with the DAQ

1. Form teams of 3 students at your recitation tables making sure that at least one team member does not have a MAC because the software does not run on a MAC.
2. Ask your T.A. to give you one of the Digilent Analog Discovery DAQs.
3. Hopefully, at least one of your team members installed the WaveForms software and the MATLAB support package for the Digilent Analog Discovery last week for Engineering Foundations. If not, have one team member (without a MAC computer) go to the Recitation Folder on the Blackboard metasite and follow the instructions for the MATLAB Update under Recitation 5.
4. Software Check #1: Use the USB cable to connect the Analog Discovery DAQ to the computer that has the software installed. Run the Waveforms Software – it should be in a folder called Digilent. **If you get a message that no device was detected, then you failed to install the Waveforms software correctly.** Go back to Blackboard, Step 1 under the Recitation 5: MATLAB Update and run the program: *digilent.waveforms V2.5.4.exe* to install the drivers and software for the Digilent. If you installed everything correctly, you should see the image below indicating the software is ready to go and is connected to the Discovery DAQ.

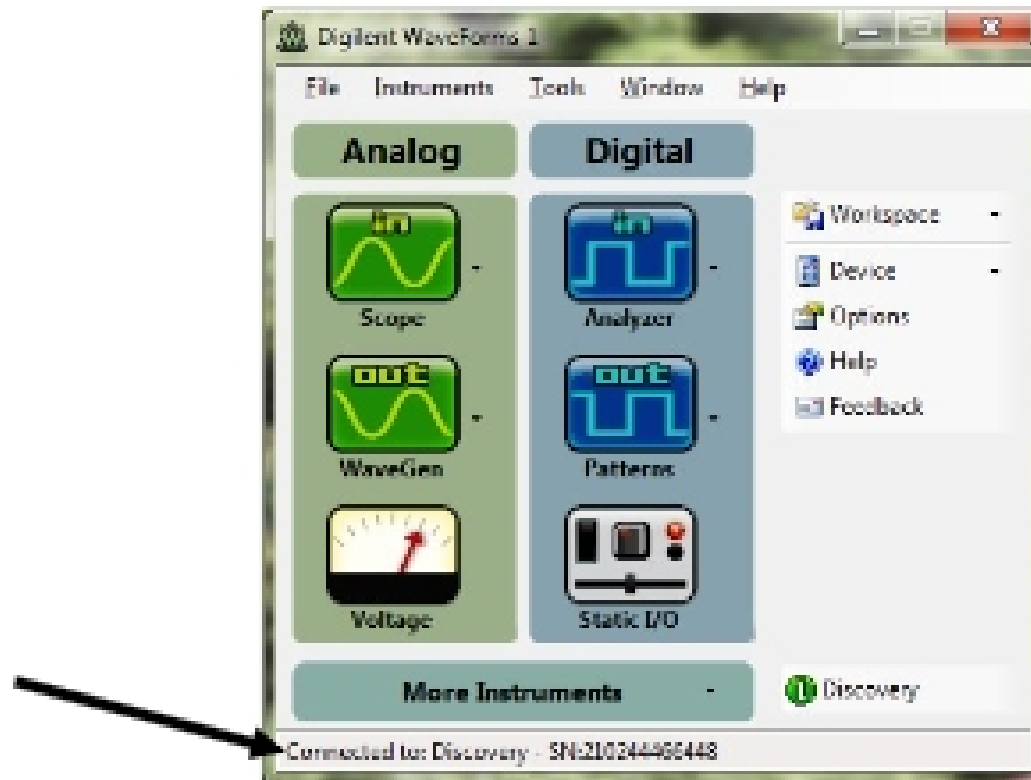

5. Software Check #2: Assuming Software Check #1 worked, **close** the Digilent Waveforms software program. Once the Waveforms software has been closed, type the following command in MATLAB: `>> clear all; d = daq.getDevices`

If you get an output like this then you are good to go:

```
d =
digilent: Digilent Inc. Analog Discovery Kit Rev. C (Device ID:
'AD1')
  Analog input subsystem supports:
    -2.5 to +2.5 volts, -25 to +25 volts ranges
    Rates from 0.1 to 1000000.0 scans/sec
    2 channels ('1', '2')
    'Voltage' measurement type

  Analog output subsystem supports:
    -5.0 to +5.0 volts range
    Rates from 0.0 to 1000000.0 scans/sec
    2 channels ('1', '2')
    'voltage' measurement type
```

Properties, Methods, Events

If you get the message that No Data Acquisition Devices Are Available, then you have not installed the MATLAB support package properly. Go back and repeat Step 2 in the Recitation 5: MATLAB Update folder; that is, run the install called *digilentanalogdiscovery.mlpkginstall*. Then try this MATLAB command once again: `>> clear all; d = daq.getDevices`

NOTE: If you lose connectivity with the DAQ at any point, type `clear all` at the command prompt. This will clear out the old session and allow you to start a new one.