

Even/Odd Mode Analysis of the Wilkinson Divider

Consider a matched Wilkinson power divider, with a source at port 2:

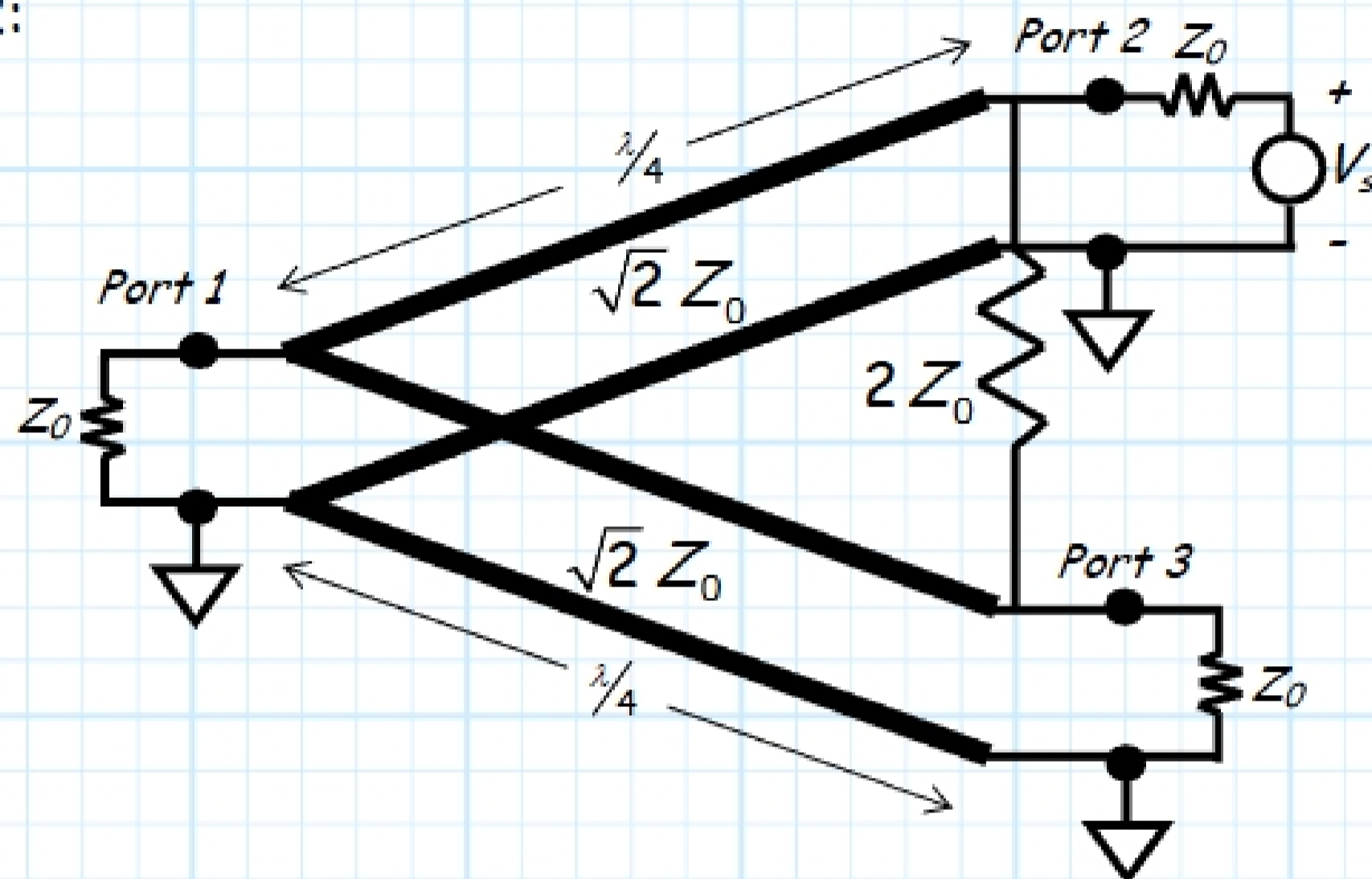

To simplify this schematic, we remove the ground plane, which includes the bottom conductor of the transmission lines:

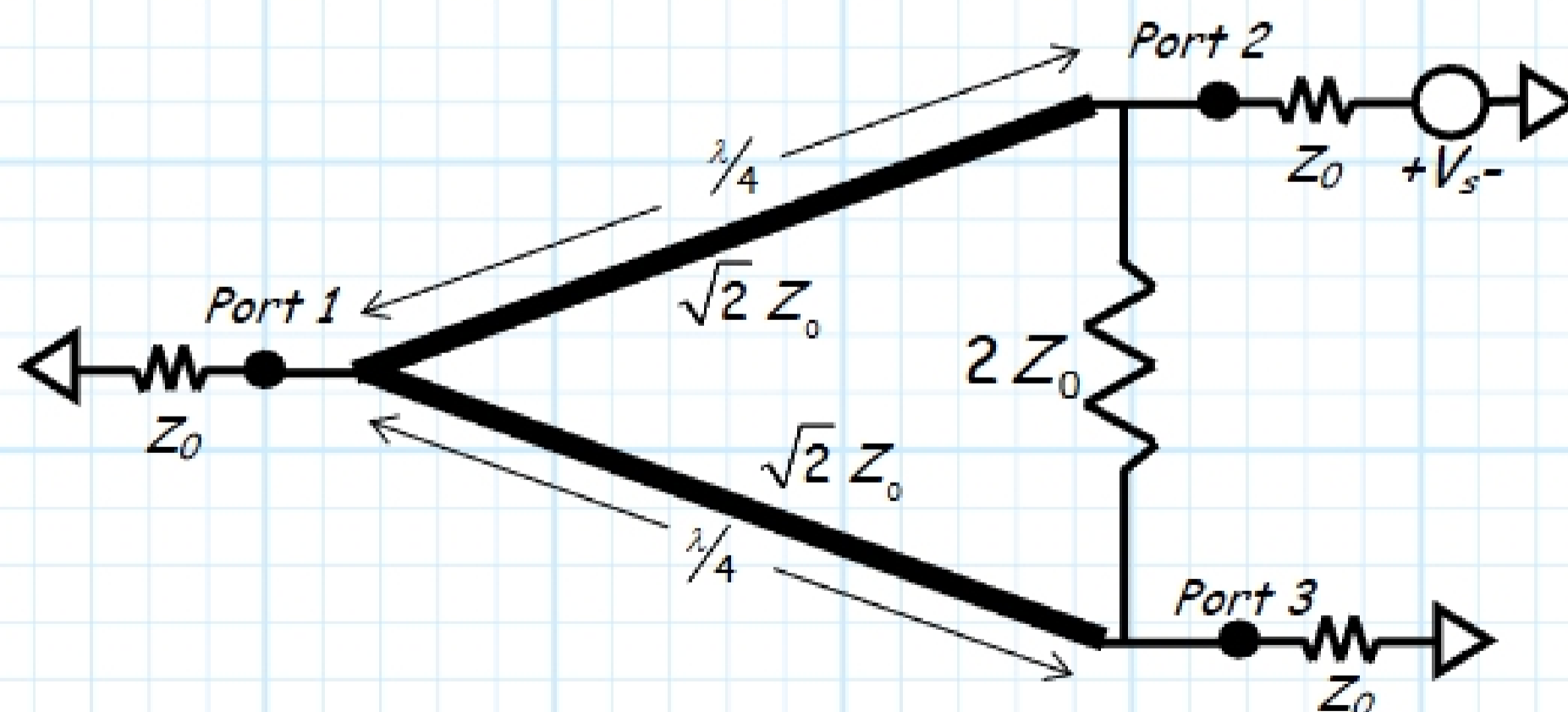

Q: How do we analyze this circuit ?

A: Use **Even-Odd mode analysis!**

Remember, even-odd mode analysis uses **two** important principles:

- a) superposition
- b) circuit symmetry

To see how we apply these principles, let's first rewrite the circuit with **four** voltage sources:

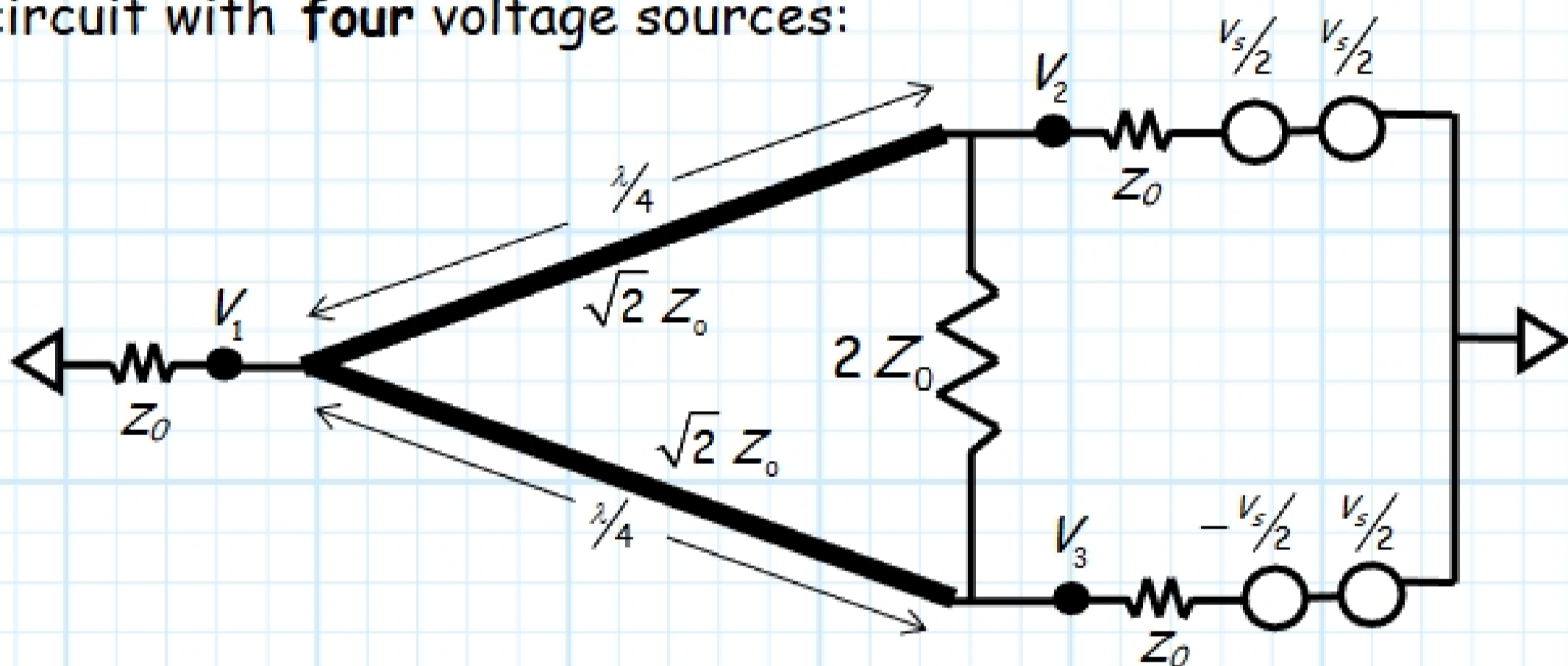

Turning off one positive source at each port, we are left with an **odd mode** circuit:

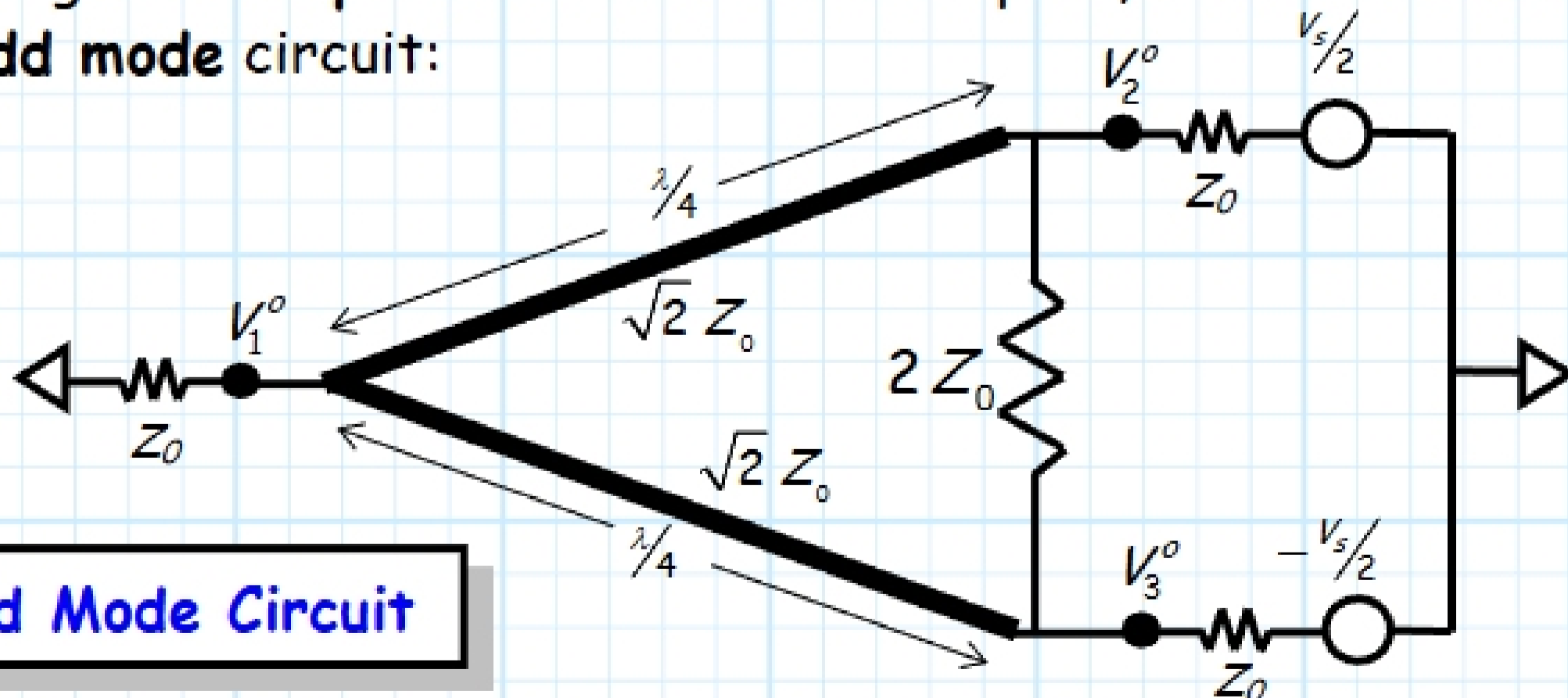

Odd Mode Circuit

Note the circuit has **odd symmetry**, and thus the plane of symmetry becomes a **virtual short**, and in this case, a **virtual ground**!

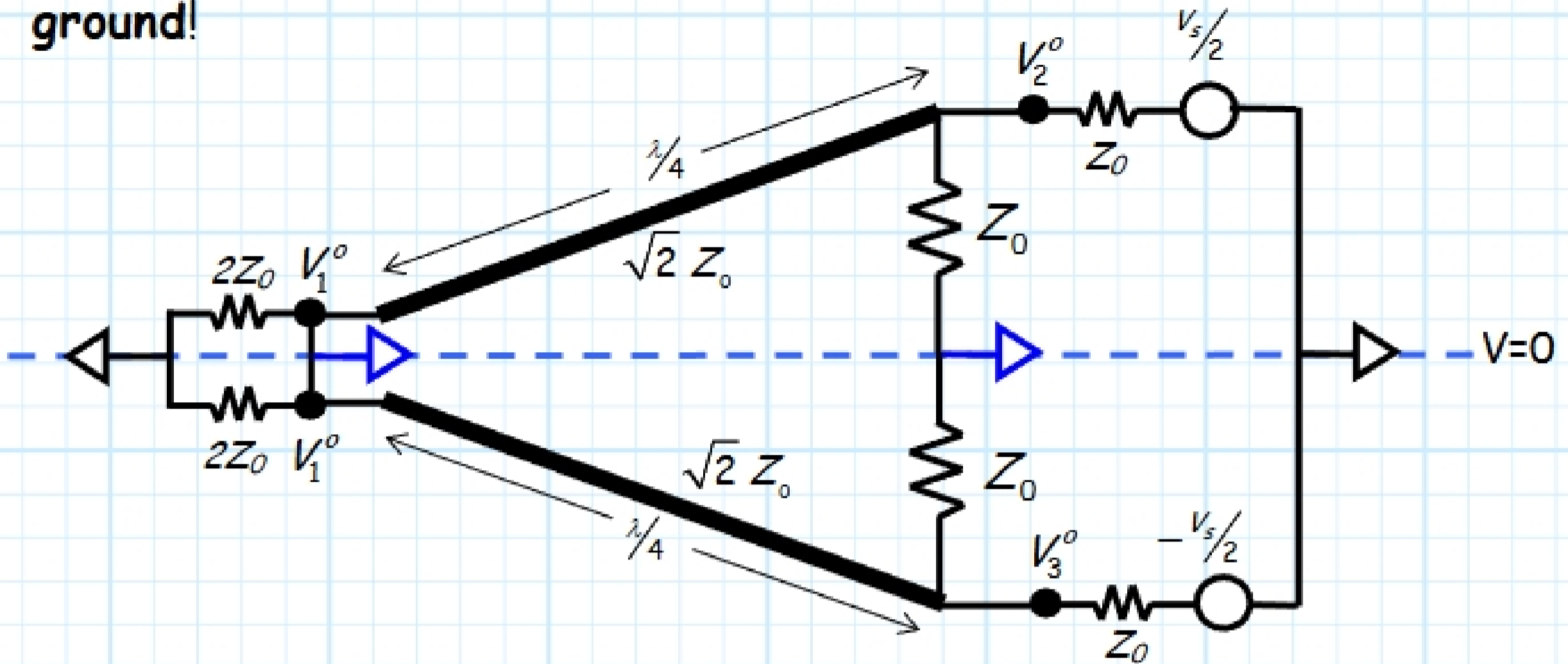

Dividing the circuit into two half-circuits, we get:

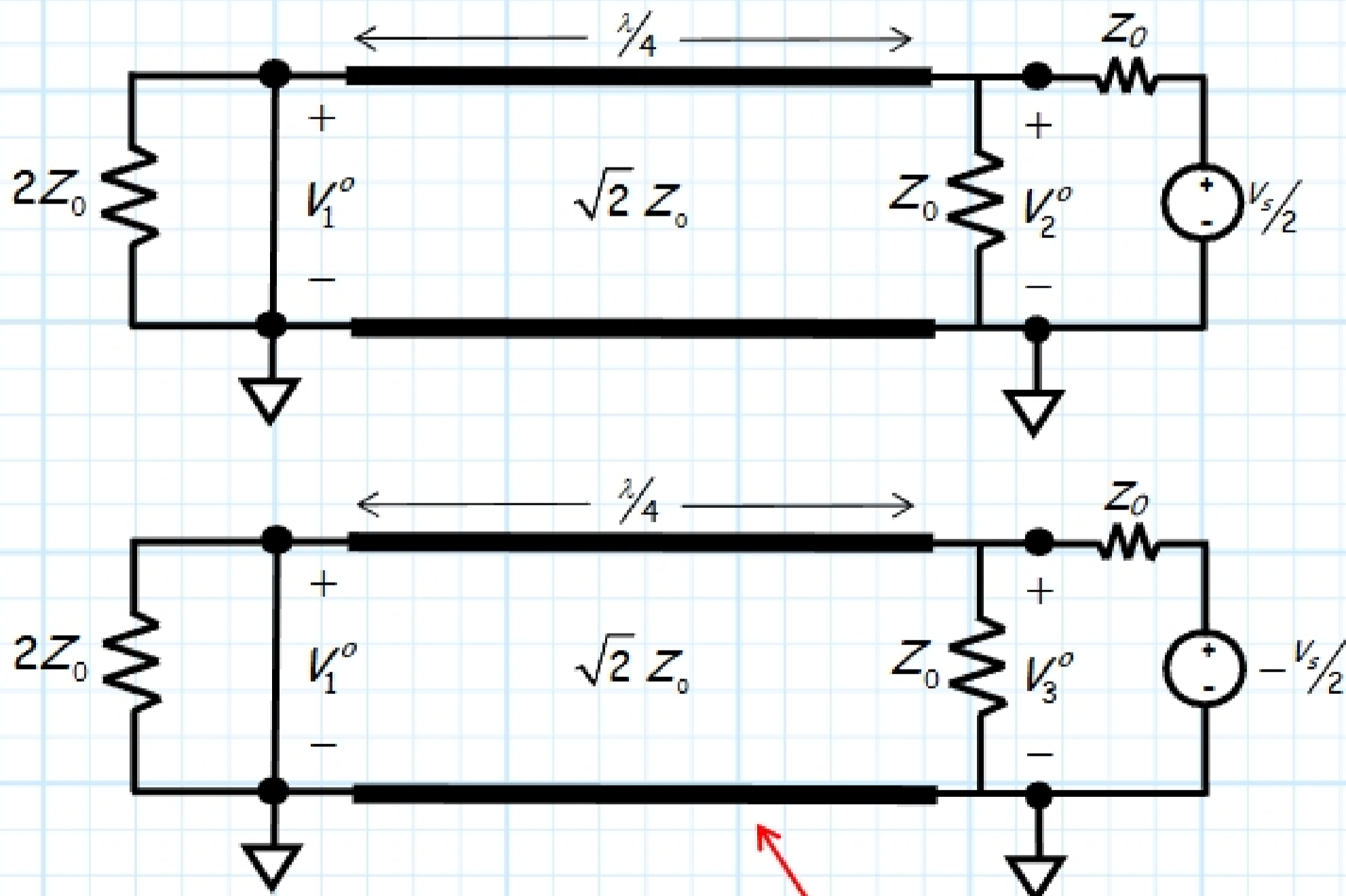

Note we have again drawn the **bottom conductor** of the transmission line (a **ground plane**) to enhance clarity (I hope!).