

PHY 2049 – Physics for Scientists and Engineers - II
 Dr. J. B. Bindell
 February 11, 1825

OLD EXAMINATION #1

Instructions: *PRINT* your name on *EACH* page of this examination. It is imperative that you are very clear in what you are doing. Use short descriptive sentences to state what you are doing. Be sure to show units in stated results. Carrying units through a calculation is often a good check of your work but not essential as long as they are correct at the end. Answers that cannot be read will be considered to be incorrect. Good luck!

Constants:

k	$8.99 \times 10^9 \text{ Nm}^2/\text{C}^2$
ϵ_0	$8.85 \times 10^{-12} \text{ C}^2/\text{Nm}^2$

Problem #1 (40 points)

In Figure 21-43, two tiny conducting balls of identical mass m and identical charge q hang from non-conducting threads of length L . Assume that θ is so small that $\tan \theta$ can be replaced by its approximate equal, $\sin \theta$ which for small angles $\sim \theta$

Using a free body diagram, find an algebraic expression for the distance of separation “ x ”. Additional space has been provided on the next page.

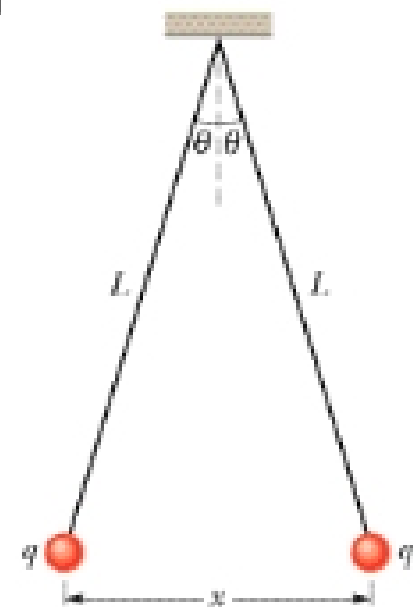

NAME _____

(Problem #1 – additional space.)

Problem #2 (30 points)

(A WebAssign Question) An electric field given by $\mathbf{E} = 2.0 \mathbf{i} - 3(y^2 + 8.0) \mathbf{j}$ pierces the Gaussian cube shown in the diagram. (E is in newtons per coulomb and x is in meters.) What is the electric flux through the following surfaces?

(a) the top face

$\text{N} \cdot \text{m}^2/\text{C}$

(b) the bottom face

$\text{N} \cdot \text{m}^2/\text{C}$

(c) the left face

$\text{N} \cdot \text{m}^2/\text{C}$

(d) the back face

$\text{N} \cdot \text{m}^2/\text{C}$

(e) the net electric flux through the cube

$\text{N} \cdot \text{m}^2/\text{C}$

