

## Lecture 41: Review Frequency Response, FET physics

Prof. J. S. Smith



Department of EECS

University of California, Berkeley

## Final Exam

- Covers the course from the beginning
- Date/Time: SATURDAY, MAY 15, 2004 8-11A
- Location: BECHTEL auditorium
- One page (Two sides) of notes

Department of EECS

University of California, Berkeley

## Q&A about the final

---

- Q: Are differential amplifiers going to be on the exam?  
A: No, there will not be a differential amplifier question.
- Q: Do we need to know a lot of device physics for BJTs?  
A: No, there won't be any BJT physics
- Q: Will there be any BJT circuits questions on the exam?  
A: No, the exam will not have any BJT transistor problems.
- Q: How much of the material from before Midterm 1 will be tested in detail?  
A: Material before midterm 1 is fair game.
- Q: Also, are we responsible for Chapter 5 i.e.- digital circuits?  
A: No, nothing specifically on digital circuits or from chapter 5.

## Last Week of Lecture

---

- Monday:
  - Review of Frequency domain analysis of linear circuits, Bode plots.
- Wednesday:
  - Frequency Response
  - Semiconductor materials, FET physics and models
- Friday:
  - Review of active linear circuits, amplifiers wrapup

## Frequency response: CS

- When we take into account a finite source impedance in a common source amplifier, the capacitances will reduce the voltage swing at the gate at high frequencies.

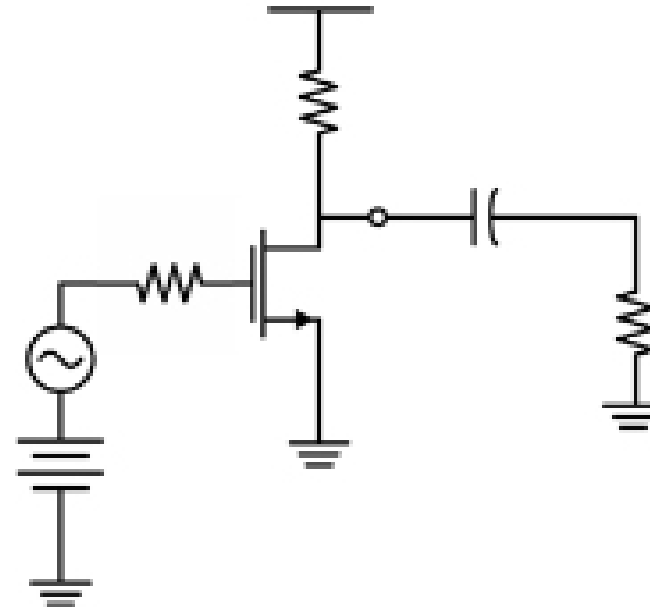

Department of EECS

University of California, Berkeley

## Parasitic Capacitances

The transfer function will be a low pass filter, with a pole at the frequency determined by the source resistance and the capacitance.

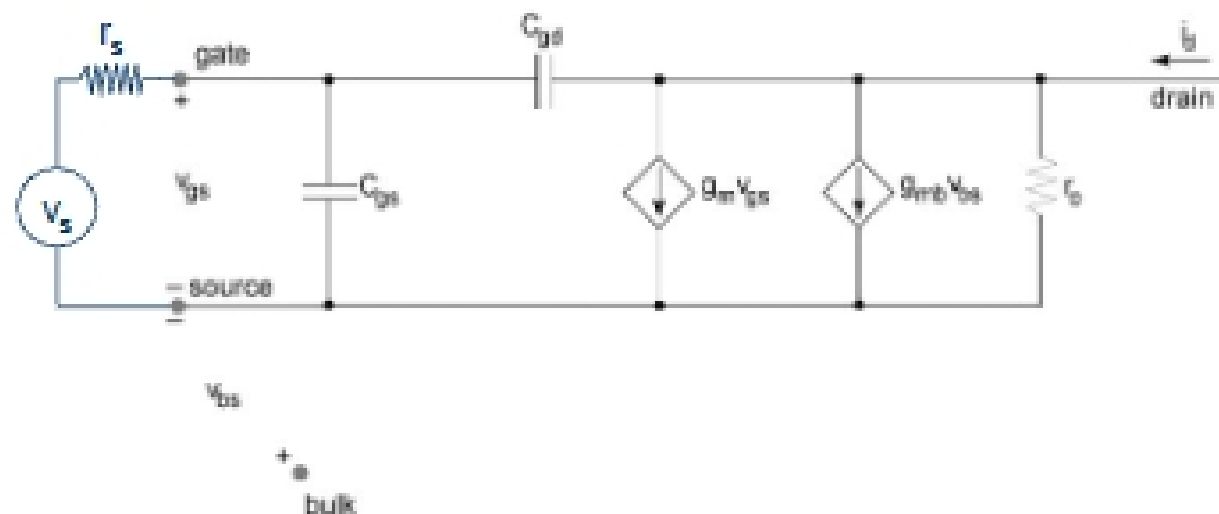

Department of EECS

University of California, Berkeley