

PROBLEM SET #5

Issued: Tuesday, Feb. 22, 2011

Due: Tuesday, Mar. 1, 2011, 5:00 p.m. in the EE 140 homework box in 240 Cory

1. Calculate the output current I_{OUT} of the CMOS Widlar current source as shown in Fig. PS5.1. $I_{IN} = 100\mu\text{A}$, $V_{DD} = 3\text{V}$, $(W/L)_1 = (W/L)_2 = 25$, $k' = 200\mu\text{A/V}$ and $R_2 = 4\text{k}\Omega$. Assume $\lambda = 0$ and ignore the body effect.

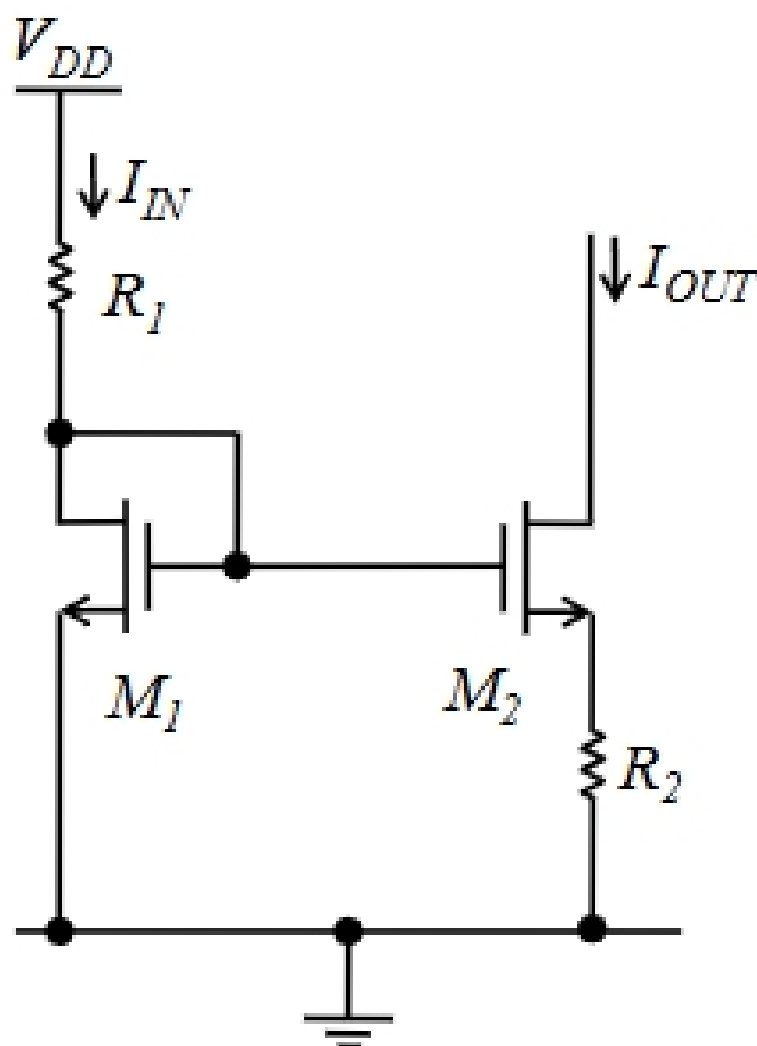

Fig. PS5.1

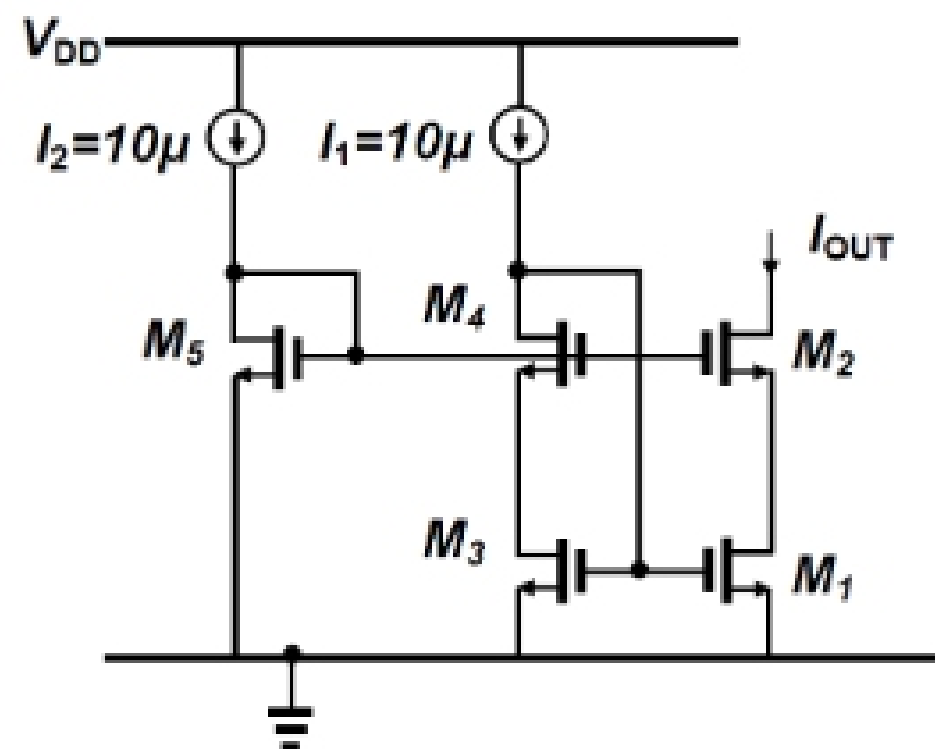

Fig. PS5.2

2. Let's consider a low voltage cascoded current mirror as shown in Fig. PS5.2. Ensure that all devices are operating in saturation. Ignore all capacitances. Assume $\lambda = 0$. Ignore the body effect. The goal is to design a low voltage cascoded current mirror. Two $10\mu\text{A}$ reference ideal current sources I_1 and I_2 are available and the desired output current is $I_{OUT} = 100\mu\text{A}$. Size the transistors in order to provide the maximum headroom at the I_{OUT} node. Find an expression for the widths and the lengths of M1, M2, M4, and M5 relative to the width and the length (W/L) of M3. Use the same length for all transistors. Size M1, M2, M3, and M4 so that these devices all have the same V_{dsat} .
3. Determine the output current and output resistance expressions as a function of V_{OUT} and I_{OUT} , respectively, for the bipolar current mirror shown in Fig. PS5.3. Find the output current and output resistance if $V_{OUT} = 1\text{V}$, 3V , and 10V . Assume beta is infinite, $V_{BE(on)} = 0.7\text{V}$, $V_A = 100$, and that all transistors are identical.

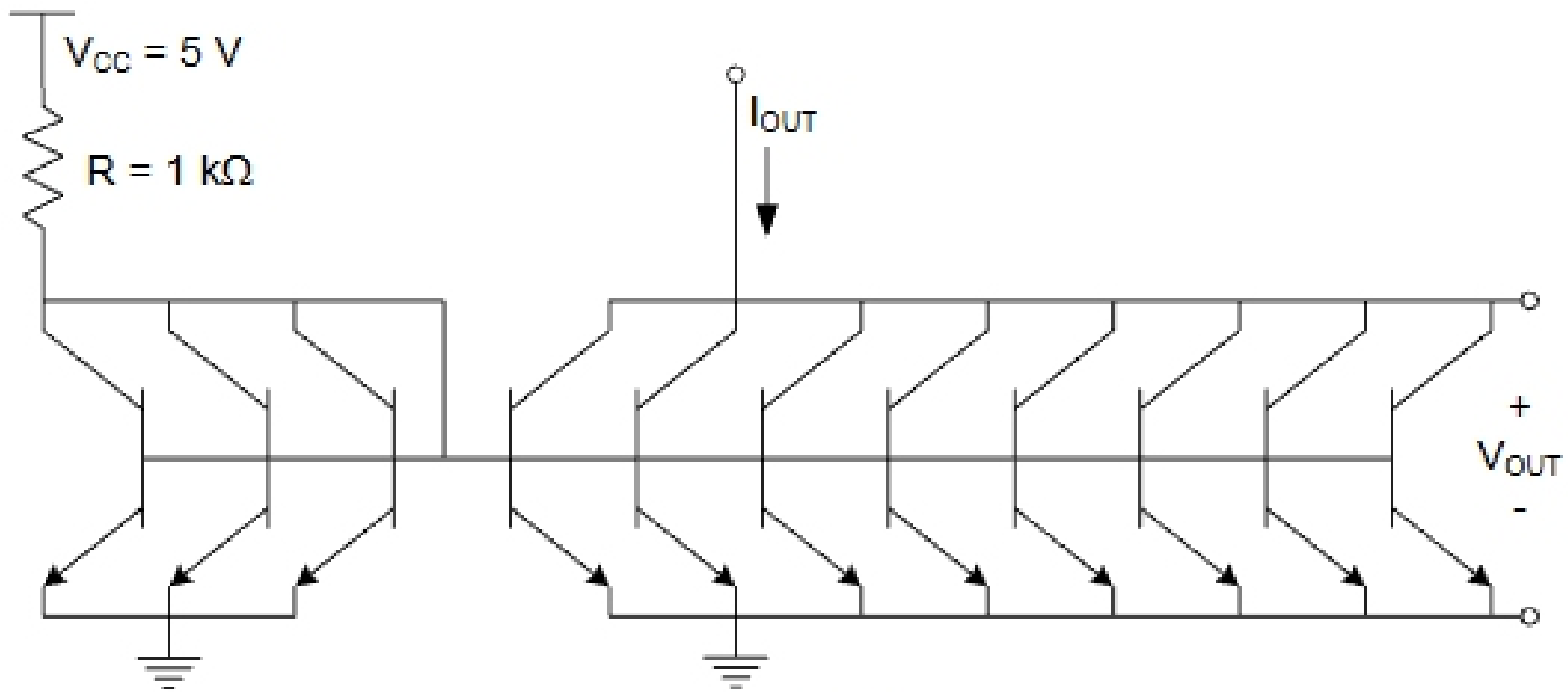

Fig. PS5.3

4. Calculate the bias current of the Widlar current source shown in Fig. PS5.4 as a function of R , $\mu_n C_{ox}$, $(W/L)_1$, and $(W/L)_2$. Ignore body effect, channel length modulation, and assume $(W/L)_3 = (W/L)_4$.

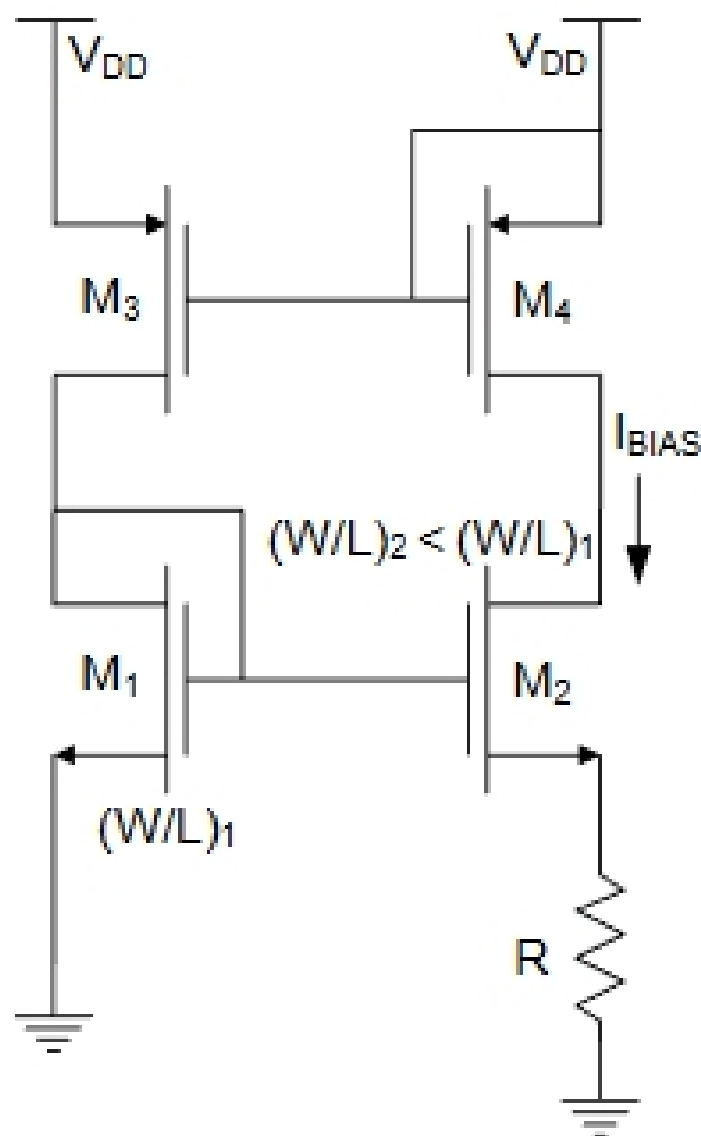

Fig. PS5.4

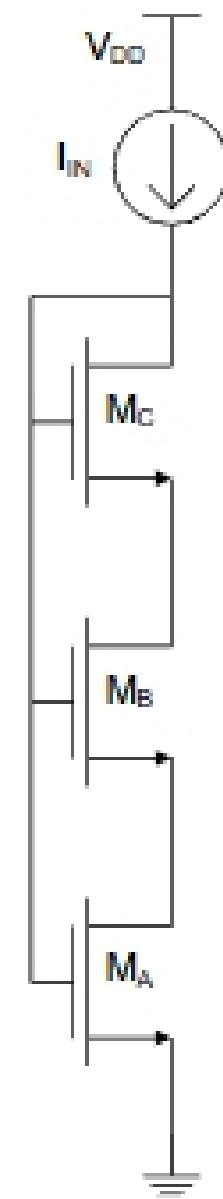

Fig. PS5.5

5. For the circuit of PS5.5, assume that $(W/L)_C = (W/L)$. Ignoring body effect, find $(W/L)_A$ and $(W/L)_B$ so that $V_{DS,A} = V_{DS,B} = V_{DSAT,C}$. Draw the schematic of a double-cascode current mirror that uses this circuit of PS5.5 to bias both cascode devices in the output branch. For this current mirror, calculate the output resistance, the minimum output voltage for which all three transistors in the output branch operate in saturation, and the total voltage across all the devices in the input branch. *Big hint: Look at Fig. 4.12 in Gray and Meyer.*