

Physics 235 Fall 2012: Final Exam
Form #1

Please print your name: _____

Instructions

1. Fill in your name above
2. Fill in your name, ID number, and **form number** on your scantron sheet
3. This will be a 2 hour, closed book exam.
4. You may use a calculator, please do not share calculators
5. The exam includes 25 multiple choice questions which will be machine graded. Each question is worth 4 points. No partial credit will be given.
6. For this exam you can bring *four* 3 x 5" cards or *one* 8 1/2 x 11" sheet of paper with any notes you wish to have. You will also find all the physical constants that you might require listed below.

Constants you might need:

$$k = 8.99 \times 10^9 \text{ Nm}^2/\text{C}^2$$

$$\epsilon_0 = 8.85 \times 10^{-12} \text{ C}^2/\text{Nm}^2$$

$$g = 9.8 \text{ m/s}^2$$

$$\mu_0 = 4\pi \times 10^{-7} \text{ Tm/A}$$

$$\text{Mass of the electron: } 9.11 \times 10^{-31} \text{ kg}$$

$$\text{Magnitude of the electron charge: } 1.6 \times 10^{-19} \text{ C}$$

$$\text{Mass of the proton: } 1.67 \times 10^{-27} \text{ kg}$$

$$1 \text{ Gauss} = 10^{-4} \text{ T}$$

$$\text{Atomic Mass Unit (1 amu): } 1.66 \times 10^{-27} \text{ kg}$$

$$\text{Speed of sound in air} = 340 \text{ m/s}$$

$$\text{Threshold of hearing } I_0 = 10^{-12} \text{ W/m}^2$$

$$\text{Speed of light in vacuum} = 3.0 \times 10^8 \text{ m/s}$$

$$k_B = 1.38 \times 10^{-23} \text{ m}^2\text{kg/s}^2\text{K} = 1.38 \times 10^{-23} \text{ J/K}$$

$$1 \text{ Astronomical Unit (1AU)} = 1.5 \times 10^{11} \text{ m}$$

1. Monochromatic LASER light of wavelength $\lambda = 670 \text{ nm}$ is incident on a slit of width a . The resulting diffraction pattern is projected onto a screen a distance $L = 3.0 \text{ m}$ away from the slit. The *third dark fringe* in the diffraction pattern appears a distance $y = 47 \text{ cm}$ from the central bright peak. What is the width a of the slit?

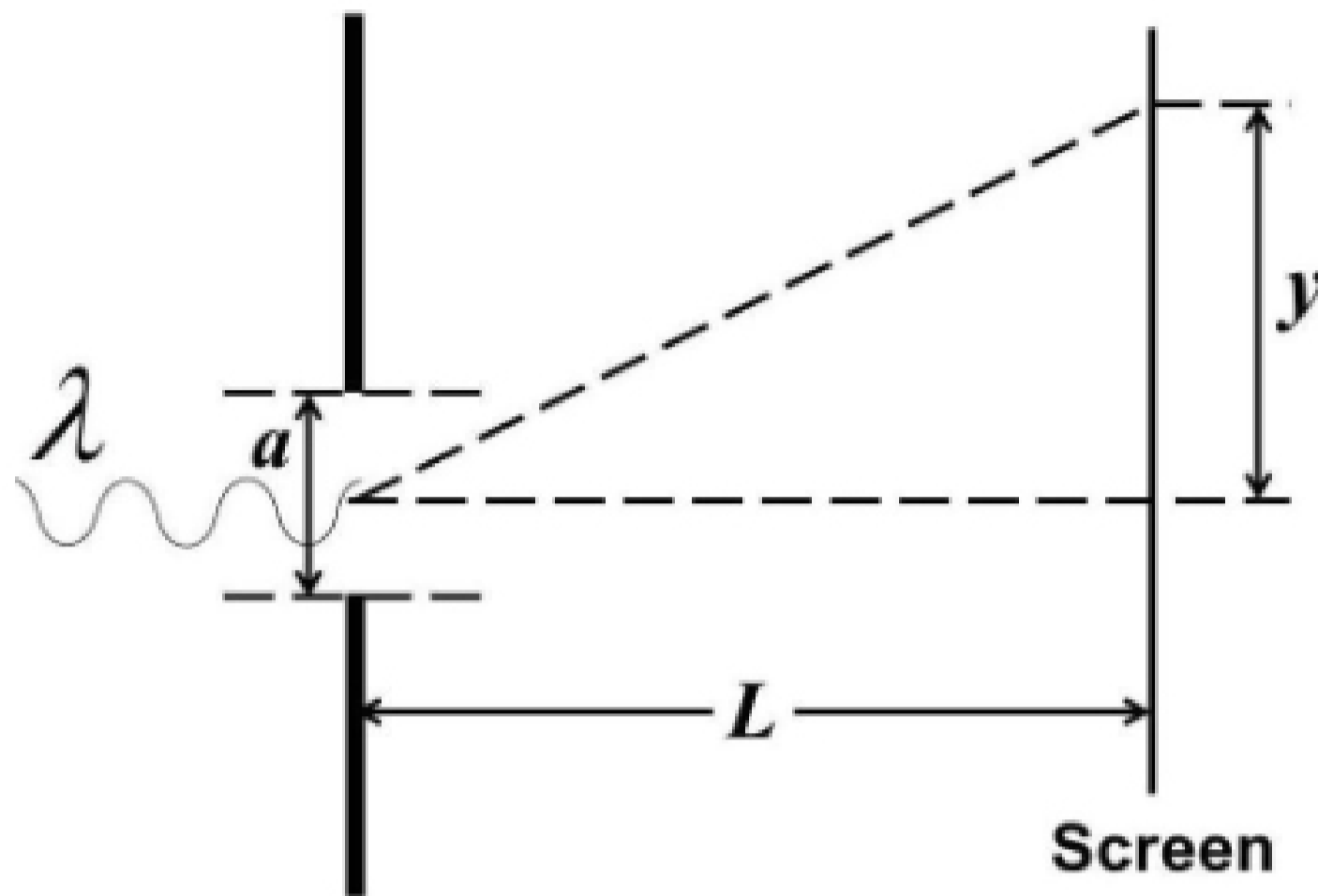

This Drawing is Not to Scale!

- A) $3 \mu\text{m}$
- B) $7 \mu\text{m}$
- C) $13 \mu\text{m}$
- D) $22 \mu\text{m}$
- E) $43 \mu\text{m}$

2. A bat is chasing a tasty bug at a speed of $v_{\text{bat}} = 7.0 \text{ m/s}$, while the bug tries to escape at a speed of $v_{\text{bug}} = 3.0 \text{ m/s}$ as shown below. The bat uses biosonar to locate the bug by making a chirping sound at a frequency of 30 kHz. What is the frequency of the sound arriving at the bug?



v_{bat} →



v_{bug} →

- A) 31.10 kHz
- B) 30.40 kHz
- C) 30.00 kHz
- D) 29.90 kHz
- E) 28.20 kHz