

Homework #3: Pipelining and Hazards(100 points)

This is an individual homework.

(Due on Monday, November 17, in Class)

1. (60 points) Pipelining:

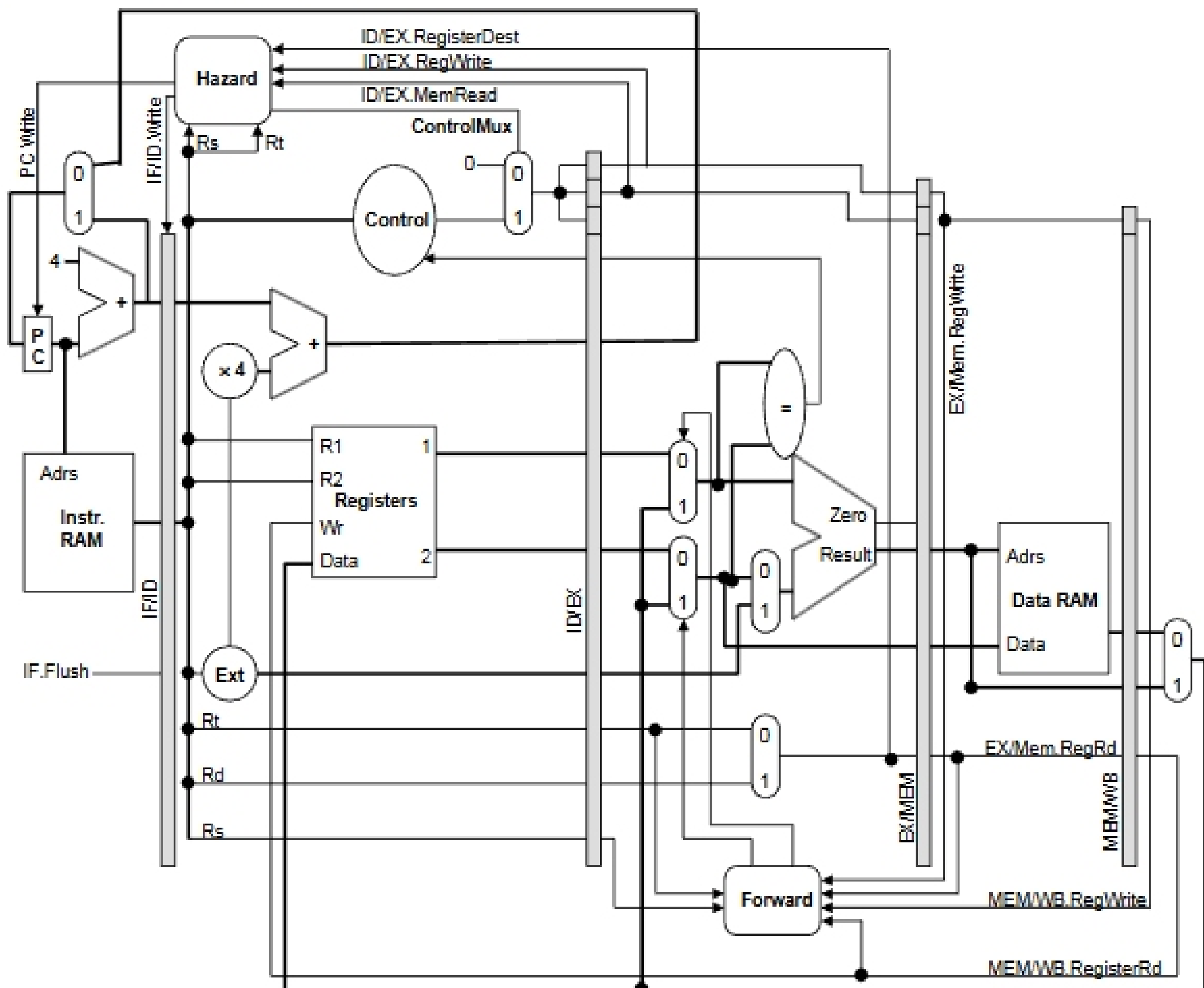

Consider the data path shown above where only partial forwarding is implemented.

Part (a). In what pipeline stage are branches resolved? How many cycles would we have to stall after a branch, if branches are not predicted? (20 points)

Part (b). Label all dependences within one iteration of this code (not just the ones that will require forwarding). One iteration is defined as the instructions between the first add and the second bne, inclusive. (20 points)

```
int count(int *A, int val, int len) {
    int count = 0, *end = A + len;
    do {
        if (*A == val) {
            count += 1;
        }
        A += 1; // pointer arith
    } while (A != end)
    return count;
}
```

The inner loop for the C code shown can be written as:

```
loop:  add    $a0,    $a0,    4
        lw    $t0,    -4($a0)
        bne   $t0,    $a1,    skip
        add   $v0,    $v0,    1
skip:  bne   $a0,    $t1,    loop
```

Part (c). Consider the code in part (b). Using the pipeline shown on the previous page (assume branches are predicted not taken), determine in which cycle each instruction is in each pipeline stage using the grid below (stalls can be marked as --). Assume that both branches are always taken. (20 points)

Inst	iter	1	2	3	4	5	6	7	8	9	0	1	2	3	4	5	6	7	8	9	0	1	2	
add	N	F	D	E	M	W																		
lw	N		F																					
bne	N																							
bne	N																							
add	N+1																							
lw	N+1																							
bne	N+1																							

2. (40 points) Instruction execution and pipeline implementation:

Fill in the datapath values (thick lined boxes) and control signal values (thin lined boxes) for each of the signals on the attached sheet (Figure 2). Use the same conventions that we used in lectures:

- Each register contains its number plus 100. For instance, register \$8 contains 108, register \$29 contains 129, and so forth.
- Every data memory location contains 99.

Feel free to place an X in any box whose value isn't important, like the constant field of an R-type instruction, but we will give 10 bonus points to anyone who computes those correctly.