

Magnetic Resonance Imaging

Components of an MRI system

- The Static Magnet
 - The permanent magnet.
 - Resistive Electromagnet
 - Superconducting Electromagnet
- RF System
 - The Transmitter is made up of an RF synthesizer, power amplifier, and transmitting coil.
 - The receiver consists of a pick-up coil, amplifier, and signal processing system.
- The Magnet Gradients
 - Magnet gradients are produced by coils that are orientated perpendicular to each other.
 - Coils are resistive magnets.
 - Produce gradients from 20 mT/m to 100 mT/m.

Some Nuclei Commonly Used in NMR

Nuclei	Unpaired Protons	Unpaired Neutrons	Net Spin	g (MHz/T)
^1H	1	0	$\frac{1}{2}$	42.58
^2H	1	1	1	6.54
^{31}P	1	0	$\frac{1}{2}$	17.25
^{23}Na	1	2	$\frac{3}{2}$	11.27
^{14}N	1	1	1	3.08
^{13}C	0	1	$\frac{1}{2}$	10.71
^{19}F	1	0	$\frac{1}{2}$	40.08

Spin in a Magnetic Field

- The nuclear magnetic moment precesses about the applied magnetic field

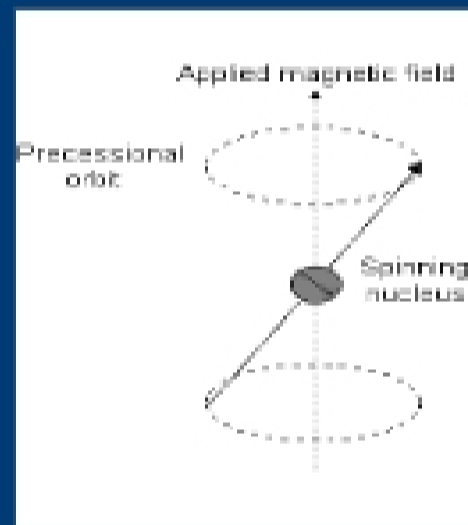

Possible nuclear spin states

- High Energy
- Low Energy

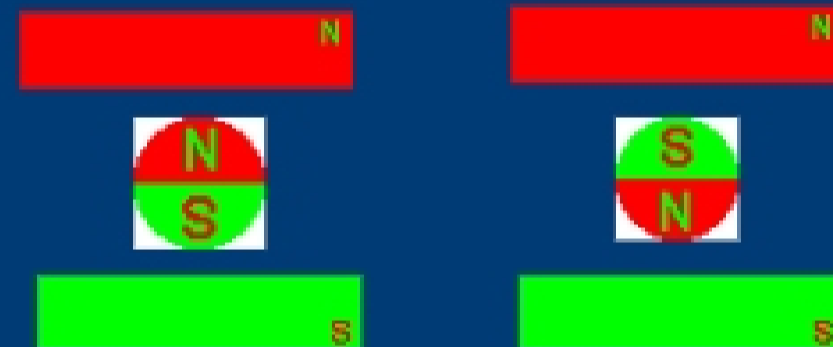

Photon Absorption

- Transition from low energy state to high energy state
- The energy needed to make the transition depends on the magnetic moment of the nucleus and the strength of the applied magnetic field

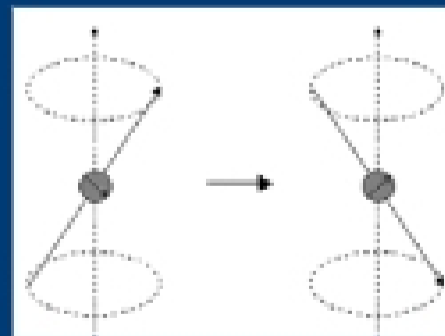

Energy Shift=Frequency of Detection

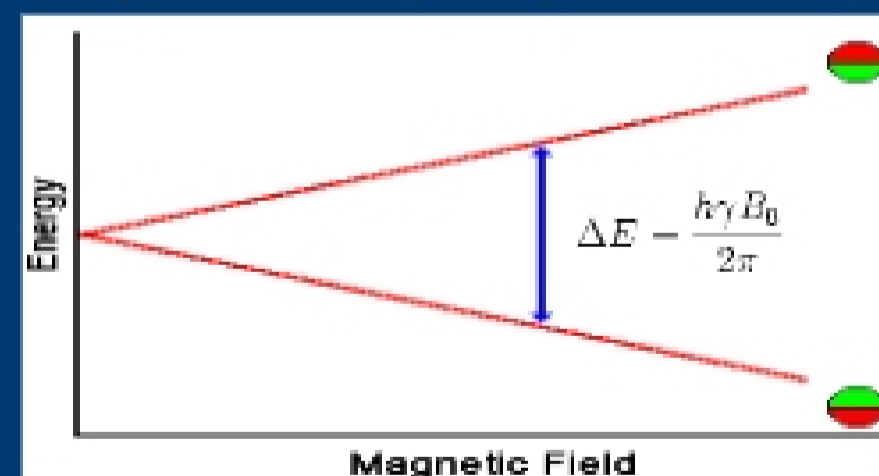

$$\nu = \frac{\gamma B_0}{2\pi}$$

Resonance

- When a magnetic field is applied to a sample of material, the majority of nuclei are in the high energy state.
- When the sample is immersed in radio waves at the resonant frequency, the high and low energy populations become equal.
- The radio frequency emitted as the sample returns to its initial state can be measured.

As energy of photons is raised, their wavelength shortens. Therefore, the resolution of an MRI image—

- A. Decreases as the magnetic field is raised
- B. Increases as the magnetic field is raised
- C. Is not affected by the magnitude of the magnetic field

Pulsed FT Spectroscopy

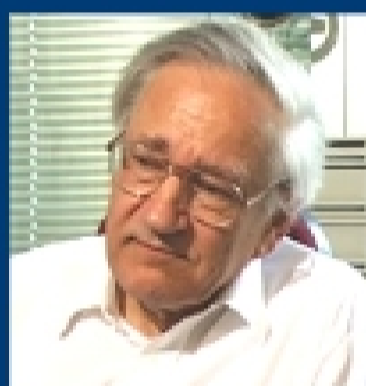

- The magnetic field is held constant and a pulse of radio waves containing a range of frequencies is sent through the sample.
- More efficient
- Richard Ernst won the Nobel Prize in Chemistry in 1991.

FT

- A Fourier Transform is used to convert the data to the frequency domain.

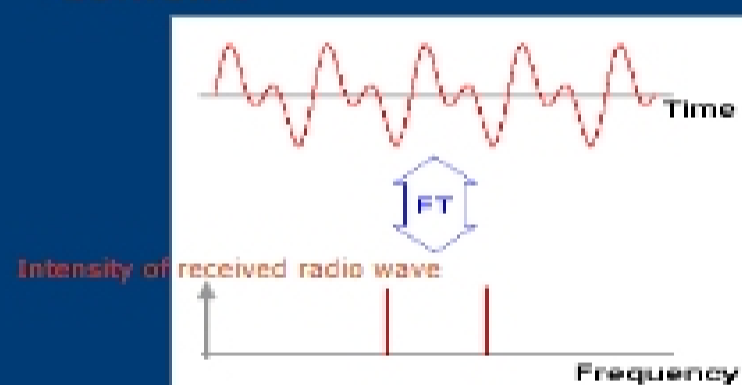

Big Magnets

- NMR spectroscopy requires very strong magnets (1 to 20 Tesla).
- A stronger magnet results in a larger energy shift.



Inside the Dewar

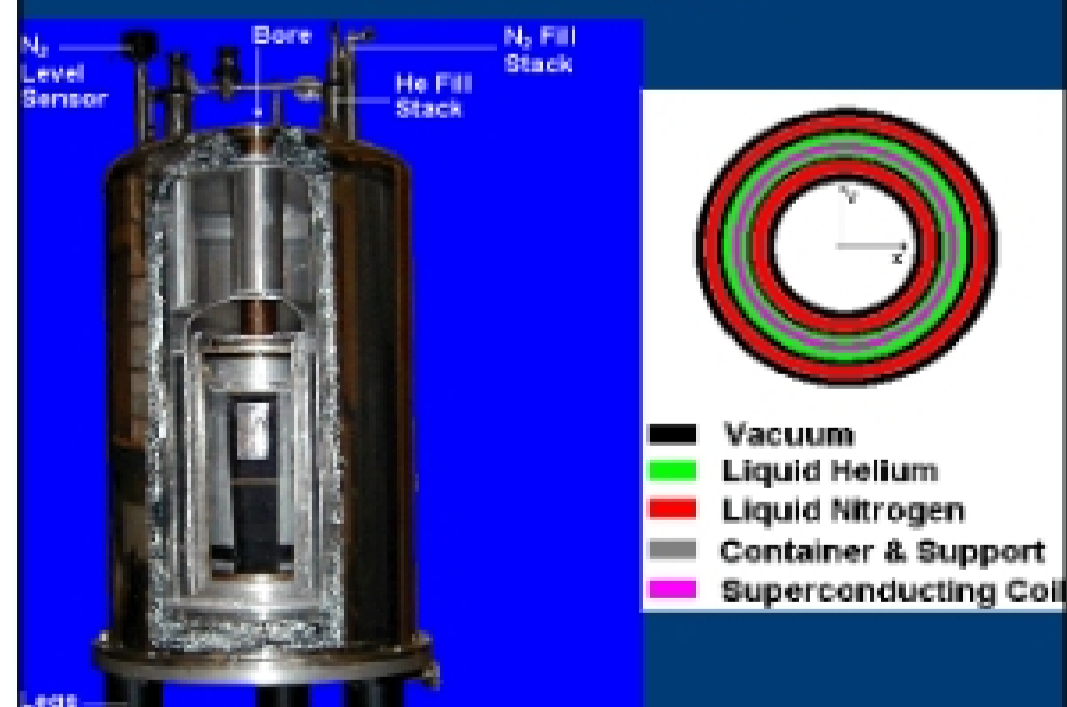

Inside the Magnet

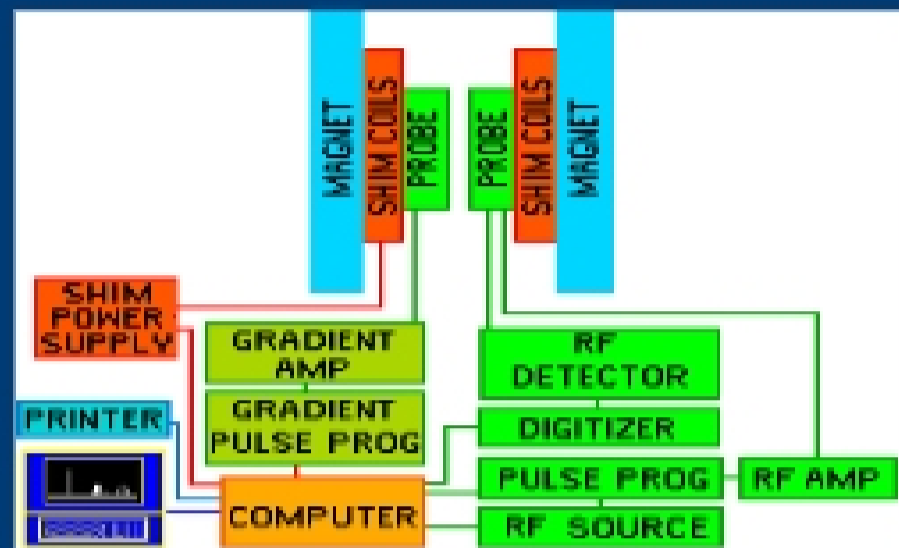

Block diagram of system

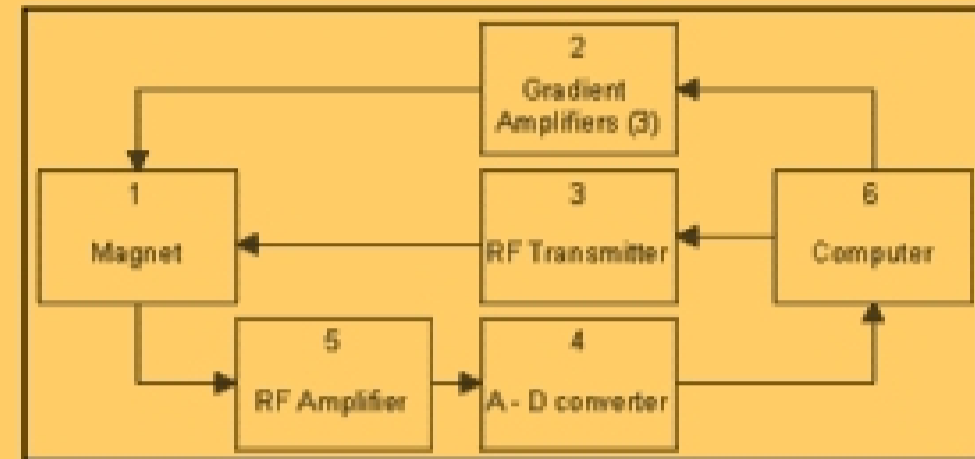

RF coils in use



Surface Coils

Surface coils are commonly used for spines, shoulders, TMJ's, and other relatively small body parts.

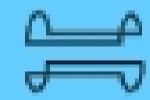

Paired Saddle Coil

Paired saddle coils are commonly used for imaging of the knee. By running current in opposite directions in the two halves of the gradient coil, the magnetic field is made stronger near one and weaker near the other.

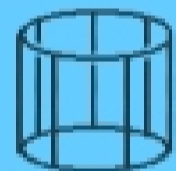

Bird Cage Coil

This coil is commonly used as a transceiver coil for imaging of the head.



Helmholtz Pair Coil

Z-gradient used occasionally as RF coils for pelvis imaging and cervical spine imaging.

What type of pick-up coil is shown here?

- A. Surface coil
- B. Birdcage coil
- C. Helmholtz coil
- D. Saddle coil

