

EE462G: Laboratory Assignment 8  
BJT Common Emitter Amplifier

by  
Dr. A.V. Radun  
Dr. K.D. Donohue (10/25/06)  
Department of Electrical and Computer Engineering  
University of Kentucky  
Lexington, KY 40506

(Lab 7 report due at beginning of the period) (Pre-lab8 and Lab-8 Datasheet due at the end of the period)

### I. Instructional Objectives

- Understand the basic operation of the bipolar junction transistor (BJT)
- Apply a DC load line to establish a DC operating point
- Perform a small signal analysis of a BJT circuit to compute small signal input and output resistance and gain
- Experimentally measure small signal input and output resistance and gain

### II. Background

A transistor (MOSFET and BJT) can be used to amplify a time-varying input signal (AC), after DC voltages are added to the AC input to ensure that the transistor is operating in its linear region (saturation region for a MOSFET, forward active region for a BJT). Transistors are nonlinear devices that can be approximated with linear models over certain regions. DC levels in the transistor circuit can be set to bias the AC signals so they operate in the linear region of the voltage-current relationships. The transistor circuit's DC currents and voltages are referred to as either the DC operating point, quiescent operating point, or bias point. Once a transistor is biased in its linear region, its currents and voltages will vary linearly with input signal changes as long as they stay within the transistor's linear range. It is assumed that the transistor's input signal variations, as well as other circuit current and voltage variations, are small enough so as not to perturb the system into nonlinear regions of operation (triode or cutoff for a MOSFET, saturation or cutoff for a BJT).

#### Bipolar Junction Transistor (BJT) Biasing

Figure 1 shows a simple common-emitter bipolar junction transistor (BJT) amplifier biasing scheme. The time varying part of the input signal is omitted to focus on the DC bias point. For the actual circuit operation the input consists of an AC signal added to a DC level at the BJT's base ( $V_{BB}$ ). The transfer characteristic (output amplitude as a function of the input amplitude) for this circuit can be derived as:

$$V_{out} = V_{CC} - \frac{\beta_f \cdot R_C}{R_B} (V_{BB} - V_f), \quad (1)$$

where  $\beta_f$  is the current gain between the collector and base current ( $I_c / I_b$ ), and  $V_f$  is the internal voltage drop over the base-emitter junction ( $V_{BE}$ ). At the operating point,  $V_{BB}$  and  $V_{out}$  are the DC or quiescent values of the input and output voltages. Ideally, for a given  $V_{BB}$ ,  $V_{out}$  should not vary much even if the temperature varies or if different transistors of the same type are used. Unfortunately the BJT's current gain  $\beta_f$  cannot be controlled well during manufacturing and so its values vary significantly even for the same component. For the PN2222 BJT transistor, manufacturers specify that  $\beta_f$  may be anywhere from 100 to 300. Thus, a circuit biased correctly for one PN2222 transistor may not be biased correctly for another PN2222 transistor. A more robust biasing scheme can be developed using feedback through an emitter resistor so that the BJT's quiescent operating point is more robust to changes in  $\beta_f$ .

Figure 2 shows a more robust design with resistor  $R_E$  placed in the emitter branch of the circuit. The DC analysis of this new circuit for the collector current results in:

$$I_C = \frac{\beta_f(V_{BB} - V_f)}{R_B + (\beta_f + 1)R_E} \quad (2)$$

Note that if  $(\beta_f + 1)R_E \gg R_B$  and  $\beta_f \gg 1$ , the collector current can be approximated as

$$I_C = \frac{(V_{BB} - V_f)}{R_E}, \quad (3)$$

which is independent of  $\beta_f$ .

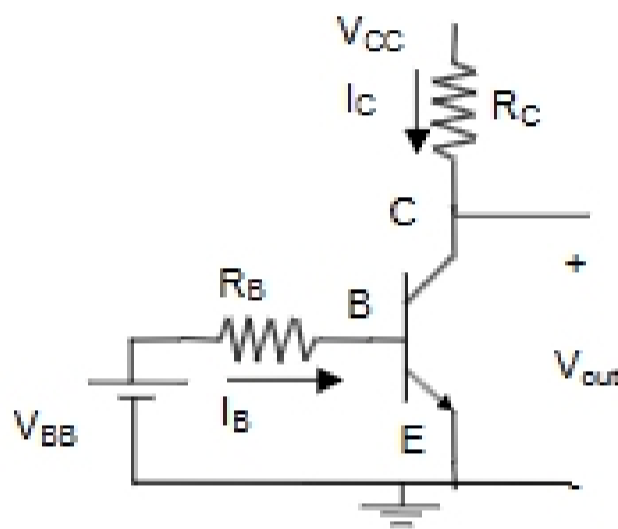

Fig. 1. Basic common emitter amplifier biasing.

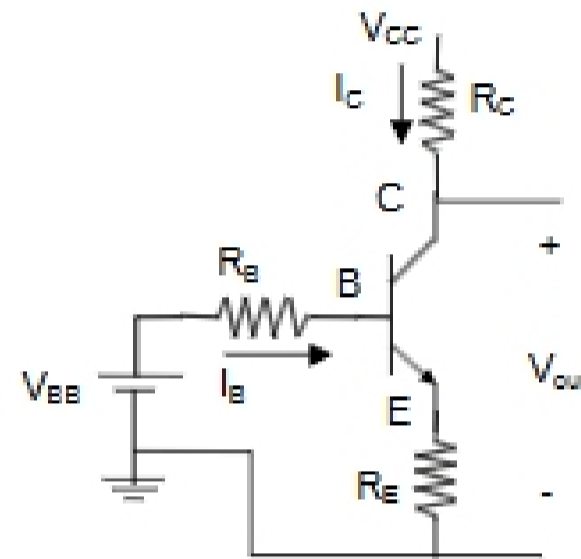

Fig. 2. Basic common emitter amplifier with reduced  $\beta_f$  sensitivity.

The schematics for these circuits indicate that two power supplies are required, one for  $V_{BB}$  and another for  $V_{CC}$ . The circuit in Fig. 3 shows a scheme where only one power supply is required. The Thévenin equivalent for the circuit consisting of  $V_{CC}$ ,  $R_1$ , and  $R_2$  in Fig. 3 results in the biasing circuit of Fig. 2, where  $V_{BB} = V_{th}$  and  $R_B = R_{th}$ . With these Thévenin equivalents substituted into the circuit, the circuit is identical to the circuit in Fig. 2 with the exception that the input bias voltage  $V_{BB}$  is now dependent on  $V_{CC}$ . The  $V_{BB}$  voltage is now controlled by the proper choice of  $R_1$  and  $R_2$ . This eliminates the need for a separate power supply to control  $V_{BB}$ .

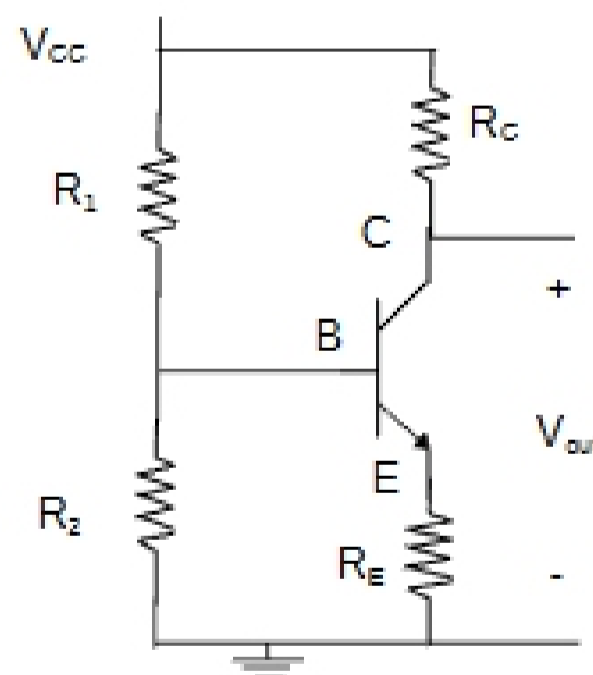

Fig. 3. Basic common emitter amplifier biasing with reduced  $\beta_f$  sensitivity and employing a single DC voltage.

Choosing the resistors  $R_1$  and  $R_2$  such that  $R_B \ll (\beta_f + 1)R_E$  is equivalent to making the current through  $R_1$  and  $R_2$  large enough such that the BJT's base current can be neglected in comparison. The base voltage is thus determined

only by  $V_{CC}$  and the  $R_1$  and  $R_2$  voltage divider. The DC Operating point of this circuit is stable for two primary reasons:

- The base voltage is determined primarily by the voltage divider  $R_1$  and  $R_2$  and is effectively independent of the transistor parameters (especially  $\beta_f$ ).
- The emitter resistor  $R_E$  stabilizes the DC operating point through negative feedback. If  $\beta_f$  increases for any reason, such as temperature change, the subsequent rise in emitter current will increase the voltage drop across  $R_E$ , thereby increasing  $V_E$  and  $V_B$  (since the drop across  $V_{BE}$  is a constant). The voltage drop across  $R_E$  is then smaller, causing a drop in  $I_B$  that counteracts the attempted increase in  $I_E$ .

Once the circuit in Fig. 3 is biased, it may be used as a voltage amplifier by connecting an input signal source to the base of the transistor, and connecting a load to the collector. These connections are coupled through a capacitor, as shown in Fig. 4, in order to prevent the source and load from altering the BJT's DC operating point. The capacitor  $C_{in}$  between the signal source and base voltage of the transistor keeps the DC voltage at the transistor base from being affected by the AC source's low impedance. In the same way, capacitor  $C_{out}$  ensures that the added load resistance does not change the DC voltage at the collector. These capacitors perform this function by being open circuits at DC. At the small AC signal frequencies, the capacitor values are chosen to have low impedance, allowing the AC signals to pass through. By the proper choice of  $C_{in}$  and  $C_{out}$  these capacitors can be treated as short circuits at the frequencies of interest.

The negative feedback that stabilizes the BJT's DC operating point also reduces the gain of the amplifier. The capacitor  $C_E$  in Fig. 4 remedies this problem by shorting out  $R_E$  for AC signals (also called "small" or "incremental" signals). Thus, the capacitor  $C_E$  effectively bypasses  $R_E$  ensuring the maximum AC gain.

The analysis of semiconductor circuits operating in their linear range is accomplished using a two-step analysis approach. The first step is the nonlinear DC or quiescent analysis. A loadline can be used to do this analysis. The second step is an AC incremental analysis where each element of the circuit is replaced by its linearized small signal model. Small signal models of common circuit elements are summarized in Table 1. A simplified small-signal model of the BJT is shown in Fig. 5. When doing a small-signal analysis each circuit element is replaced with its small signal equivalent producing a new small-signal equivalent schematic of the original circuit. Because the incremental circuit is linear, all of the linear circuit theory can be brought to bear in analyzing the small signal equivalent circuit including phasors, Fourier analysis, impulse response, and superposition. Also, once the linear circuit has been obtained, approximations can be used to simplify it further. For example, capacitors can often be treated as short circuits at the frequencies of interest.

Circuit element	Schematic	Small signal circuit element	Small signal schematic
Wire	—	Wire	—
Resistor		Resistor	
Capacitor		Capacitor or short for small $1/(j\omega C)$	or —
Inductor		Inductor or open for large for small $(j\omega L)$	or — —
DC voltage source		Short	—
DC current source		Open	— —