

EE 462: Laboratory Assignment 9
The BJT Differential Amplifier

by
Dr. A.V. Radun
Dr. K.D. Donohue (3/29/06)
Department of Electrical and Computer Engineering
University of Kentucky
Lexington, KY 40506

Simulation-only Lab # 9 Due at Next lecture period

I. Instructional Objectives

- Simulate a simple differential amplifier in SPICE
- Determine common mode and differential mode gains
- Determine the common mode rejection ratio

II. Introduction

See 2.1 – 2.6, 8.1, 8.2, and 8.3 in Horenstein

Previous experiments have used circuits designed for a discrete circuit implementation. However, most modern circuits are built as integrated circuits on a single silicon chip. Integrated circuits provide lower cost, higher speed, and lower power dissipation. On the other hand there are limitations that an integrated circuit implementation imposes on the types and size of components that can be used. For instance, capacitors above ~ 50 pF would occupy too much area in an integrated circuit (chip); similarly, large valued resistors require prohibitively large amounts of space. Since transistors occupy little chip area, they are used liberally in integrated circuits. In addition, transistors on the same chip are well matched with almost identical values of β and other fabrication parameters unlike the case of discrete transistors where it is very difficult to match the BJT's β . This fact makes it possible to implement certain multi-transistor circuits in an integrated circuit that would be very difficult to implement with a discrete transistor design. One such circuit is the differential amplifier. Two versions of the differential amplifier are shown in Fig. 1.

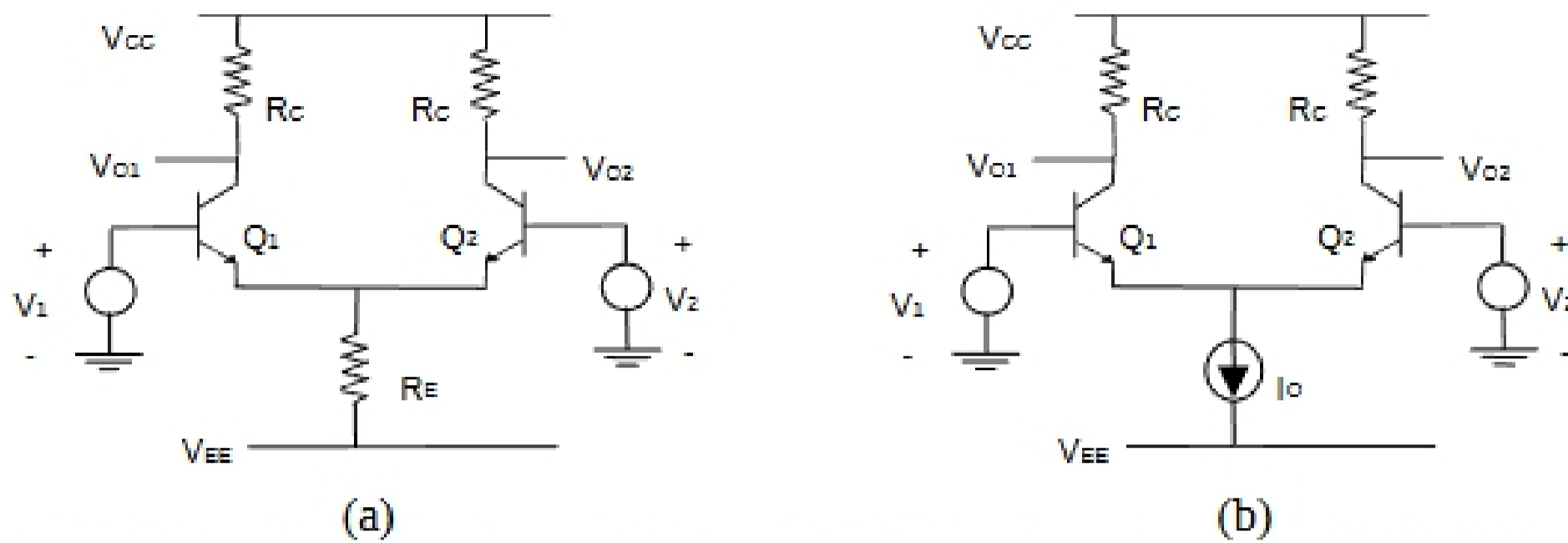

Fig. 1. Differential amplifiers emitter branch with (a) resistor for negative feedback, and (b) active low impedance bypass element to ground.

In order to maintain a stable bias for changing values of β , a single transistor amplifier requires significant negative feedback. This was accomplished by using an emitter resistor in the previous lab as shown in Fig. 1a. This same negative feedback reduces the amplifiers gain, so a bypass capacitor was included to short the emitter resistor to ground for the AC signals to be amplified. The use of this bypass capacitor prohibits the effective use of the amplifier at low frequencies. In addition, the large resistor and capacitor values cannot be used in an integrated circuit. A solution to this problem is to add another active device to provide the required low impedance bypass to ground. One example of such a configuration is shown Fig. 1b.

A properly designed differential amplifier will amplify the difference between the two input signals V_1 and V_2 ($V_1 - V_2$) by a large gain factor and suppress the average or common component of the input signals $(V_1 + V_2)/2$. Thus the differential gain is large and the common mode gain is small, ideally zero. The current source, I_o (in Fig. 1b), serves to bias (provide the DC component) both of the transistors. In reality, a current source must be synthesized from various components. The crudest, yet easiest, approximation to a current source is a resistor as shown in Fig. 1a.

The two input voltages can be expressed as linear combinations of the differential input $V_{idm} = V_1 - V_2$, and common mode input $V_{icm} = (V_1 + V_2)/2$. These equations constitute a linear transformation from (V_1, V_2) to (V_{idm}, V_{icm}) . This transform is invertible so that the above equations can be solved for the input voltages in terms of V_{idm} , and V_{icm} . Since for a linear system, superposition holds, the output voltage for any arbitrary combination of V_1 and V_2 can be found once the voltage gain expressions for a pure differential input and a pure common mode input are known. The output only consists of a differential output when $V_1 = -V_2$, which corresponds to $V_{icm} = 0$. The output only consists of a common mode output when $V_1 = V_2$ corresponding to $V_{idm} = 0$.

The differential mode gain with respect to the output V_{out1} (measured with respect to ground) is defined as V_{out1} / V_{idm} with $V_{icm} = 0V$ and is called A_{dmse1} (gain differential mode single ended 1), likewise, the differential mode gain A_{dmse2} (gain differential mode single ended 2) with respect to the output V_{out2} is defined as V_{out2} / V_{idm} with $V_{icm} = 0V$.

The common mode gain with respect to the output V_{out1} is defined as V_{out1} / V_{icm} with $V_{idm} = 0V$ and is called A_{cmse1} (gain common mode single ended 1), likewise, the common mode gain A_{cmse2} (gain common mode single ended 2) with respect to the output V_{out2} is defined as V_{out2} / V_{icm} with $V_{idm} = 0V$. Either output may be found by combining these two gains (using superposition) as follows:

$$V_{out1} = A_{dmse1} \cdot V_{idm} + A_{cmse1} \cdot V_{icm} = A_{dmse1} \cdot (V_1 - V_2) + A_{cmse1} \cdot \left[\frac{V_1 + V_2}{2} \right] \quad (1)$$

$$V_{out2} = A_{dmse2} \cdot V_{idm} + A_{cmse2} \cdot V_{icm} = A_{dmse2} \cdot (V_1 - V_2) + A_{cmse2} \cdot \left[\frac{V_1 + V_2}{2} \right] \quad (2)$$

The expressions for the differential and common mode gains can be found using a small signal analysis of the circuit as usual (see Microelectronic Circuits and Devices by Mark Horenstein for sample derivations).

The overall differential mode gain for the differential output $V_{out1} - V_{out2}$ is $A_{dm\text{diff}} = A_{dmse1} - A_{dmse2}$ (gain differential mode differential) and the overall common mode gain is $A_{cm\text{diff}} = A_{cmse1} - A_{cmse2}$ (gain common mode differential). The purpose of the differential amplifier is to amplify the differential mode component of the input and to suppress the common mode component of the input (make the differential mode gain as high as possible and the common mode gain as small as possible). An important characterization of the differential amplifier is its common mode rejection ratio defined as $CMRR = 20 \log |A_{dm\text{diff}} / A_{cm\text{diff}}|$.

III. Simulation Exercises

1. Choose values for R_C and R_E so that the bias current through R_E is approximately 2 mA and both transistor's V_{CE} is approximately 5V (for quiescent analysis set $V_1 = V_2 = 0V$). Use $V_{CC} = -V_{EE} = 12V$, $\beta = 100$, and $V_{BEf} = 0.6V$. Show your work.
2. Simulate the circuit using SPICE to determine the gain differential mode differential $A_{dm\text{diff}}$, the gain common mode differential $A_{cm\text{diff}}$, and the CMRR. To model the imperfections of a real circuit, set one transistor β -value to 80 and the other to 120. You may have to make one of transistor models unique or else the values will keep changing for both transistors. There should be an option for this under the "edit simulation model" option. Use a frequency of 1kHz for the input. (Hints: The common mode gain is found by connecting the two amplifier inputs together and driving them from a single source to ground. The differential mode gain is found by connecting two different sources to the two amplifier inputs, making one the negative of the other (180 degrees out of phase). Use small values for the input voltages so waveforms do not exhibit saturation effects. Hand in a hard copy of your spice circuit with all plots generated to obtain the requested values. Indicate the requested values clearly, and show how you computed them from the numbers obtained from the figures.