

ECE 6345  
Spring 2011

Homework 2

- 1) A certain probe-fed microstrip antenna has a resistance of  $50 \text{ } \Omega$  at resonance. The bandwidth (defined by  $\text{SWR} < 2$ ) is 2%. The resonance frequency is 2.0 GHz. Assume that the probe inductance is negligible.
  - a) Plot the input resistance and reactance versus frequency for this antenna, from 1.9 to 2.1 GHz.
  - b) Plot  $|S_{11}|$  versus frequency over the same range, assuming that the antenna is fed by a  $50 \text{ } \Omega$  feed line.
  - c) Plot the normalized input impedance for this antenna on the Smith chart, over the same frequency range.
- 2) Redo the previous problem, assuming now that the probe reactance is  $j10 \text{ } \Omega$ . (The probe reactance may be assumed to be constant over the frequency range of interest.) Comment on how the probe reactance affects the various plots.
- 3) A probe-fed microstrip antenna has an input resistance of  $50 \text{ } \Omega$  at resonance. The probe reactance may be neglected. What is the input impedance of this antenna at the frequencies  $f_1$  and  $f_2$ ? These are the two frequencies (lower and upper) at which the SWR is 2.0, when the antenna is fed by a  $50 \text{ } \Omega$  feed line.
- 4) Show that when the probe inductance is accounted for, the resonance frequency  $f_{res}$  (where in the input impedance is purely real) is given by

$$X_{res} = \frac{1 - \sqrt{1 - 4\bar{X}_p^2}}{2\bar{X}_p}$$

where

$$X_{res} = Q \left( \frac{f_{res}}{f_r} - \frac{1}{f_r} \right)$$

$$f_r^{res} = \frac{f_{res}}{f_0}$$

$$\bar{X}_p = X_p / R.$$

- 5) As a continuation of the previous problem, denote  $f_0$  as the resonance frequency of a probe-fed microstrip antenna when the probe inductance is neglected. Let  $f_{res} = f_0 + \Delta f$  be the resonance frequency when the probe inductance is included. That is,  $f_{res}$  is the frequency for

which the input impedance of the microstrip antenna (including the probe inductance) is a real number. Derive the following approximate formula for the shift in resonance frequency due to the probe inductance:

$$\frac{\Delta f}{f_0} = (\text{BW}) \frac{1}{\sqrt{2}} \frac{X_p}{R}$$

where BW is the bandwidth of the antenna (SWR < 2 definition),  $X_p$  is the probe reactance (assumed to be constant over the frequency range of interest), and  $R$  is the input resistance at frequency  $f_0$ .

- 6) Consider a microstrip patch antenna that is gap coupled (with a small gap) to a microstrip line (i.e, there is a capacitive gap between the line and the patch). The gap is represented as a series capacitor  $C_g$ . What will the input resistance seen by the feeding line be (at the gap location) when the patch is operating at the resonance frequency where the input impedance is purely real? Assume that the patch is modeled as an RLC circuit with known values of ( $R$ ,  $L$ ,  $C$ ) when the patch is fed by a direct contact at the edge. From your result, explain how the gap coupling can be used to lower the input resistance seen by the feed line, from  $R$  to a lower value  $R_{in}^{gap}$ .
- 7) As we saw in the short-course notes, using a double-tuned resonator effect is a good way to increase the bandwidth of a microstrip antenna. Consider one microstrip antenna that is capacitively coupled to another one. An approximate model for this is shown below. The capacitor  $C_0$  is the coupling capacitance between the two antennas.

Show that the input admittance of this circuit is approximately

$$Y_{in} = Y_1 + \frac{Y_2}{1 - j(Y_2/B_c)}$$

where  $Y_1$  is the input admittance of antenna tank circuit one,  $Y_2$  is the input admittance of antenna tank circuit two, and  $B_c = \omega_0 C_0$ , where  $\omega_0$  is the center frequency of the double-tuned circuit.

The input admittances of the antenna tank circuits can be written as

$$Y_1 = \frac{1}{R_1} \left[ 1 + jQ_1 \left( f_{r1} - 1/f_{r1} \right) \right]$$

$$Y_2 = \frac{1}{R_2} \left[ 1 + jQ_2 \left( f_{r2} - 1/f_{r2} \right) \right]$$

where

$$f_{r1} = \frac{f}{f_{01}}$$

and

$$f_{r2} = \frac{f}{f_{02}}.$$

Note that we can write

$$f_{r2} = \frac{f_{r1}}{1 + \Delta},$$

where

$$\Delta = \frac{f_{02} - f_{01}}{f_{01}}$$

is the normalized shift in resonance frequencies between the two antenna tank circuits (you should show this).

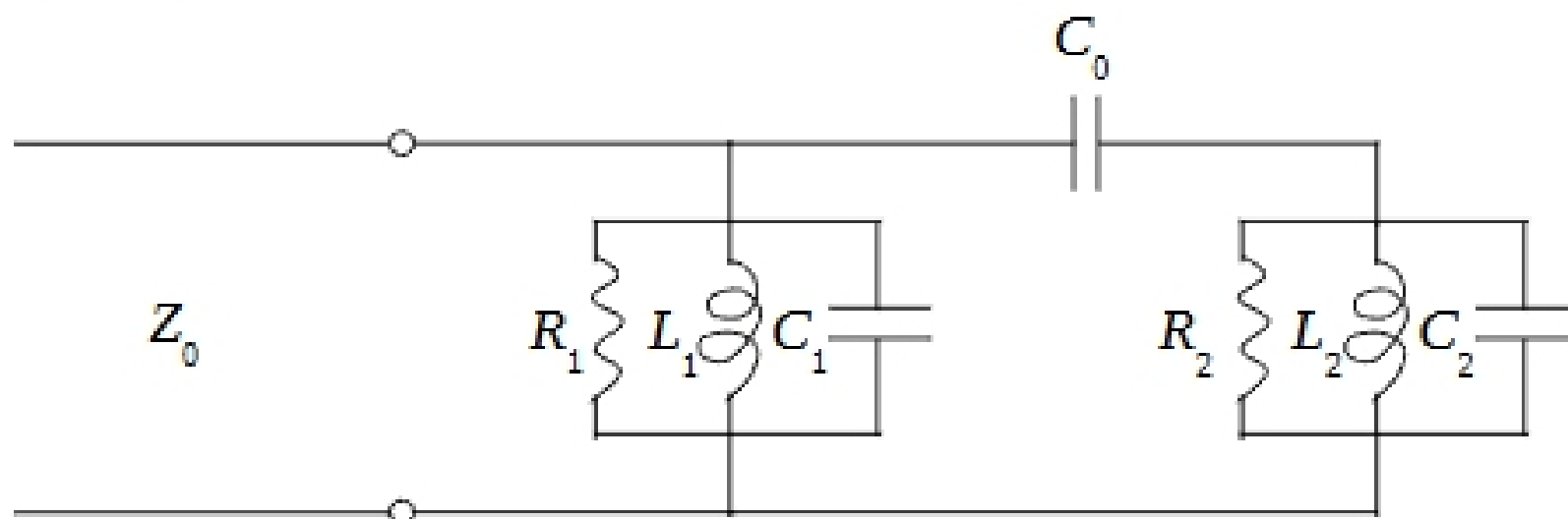

- 8) Make a plot of SWR vs.  $f_{r1}$  for the following case:  $R_1 = 50 \text{ } [\Omega]$ ,  $Q_1 = 25$ ,  $R_2 = 100 \text{ } [\Omega]$ ,  $Q_2 = 25$ ,  $B_s = 0.0001$ ,  $\beta = 0.009$ , and  $Z_0 = 50 \text{ } [\Omega]$ . Because of the very small value of  $B_s$ , This corresponds to the response of the single resonator 1. Determine the bandwidth from your plot. Compare with the bandwidth from the formula

$$BW = \frac{1}{\sqrt{2}Q_1}.$$