

Last Name (Print): _____

First Name (Print): _____

ID number (Last 4 digits): _____

Section: _____

DO NOT TURN THIS PAGE UNTIL YOU ARE TOLD TO DO SO

Problem	Weight	Score
1	25	
2	25	
3	25	
4	25	
Total	100	

INSTRUCTIONS

1. You have 2 hours to complete this exam.
2. This is a closed book exam. You may use one $8.5'' \times 11''$ note sheet.
3. Calculators are allowed.
4. Solve each part of the problem in the space following the question. If you need more space, continue your solution on the reverse side labeling the page with the question number; for example, **Problem 1.2 Continued**. **NO** credit will be given to solutions that do not meet this requirement.
5. **DO NOT REMOVE ANY PAGES FROM THIS EXAM.** Loose papers will not be accepted and a grade of **ZERO** will be assigned.
6. The quality of your analysis and evaluation is as important as your answers. Your reasoning must be precise and clear; your complete English sentences should convey what you are doing. **To receive credit, you must show your work.**
7. Any student caught cheating on an exam will receive a grade of zero for the exam. Additional sanctions, including assigning an **XF** grade, will be pursued following university guidelines.

Problem 1: (25 Points)

1. (11 points) Figure 1 shows the circuit diagram of a Moore finite state machine with input x and output y .

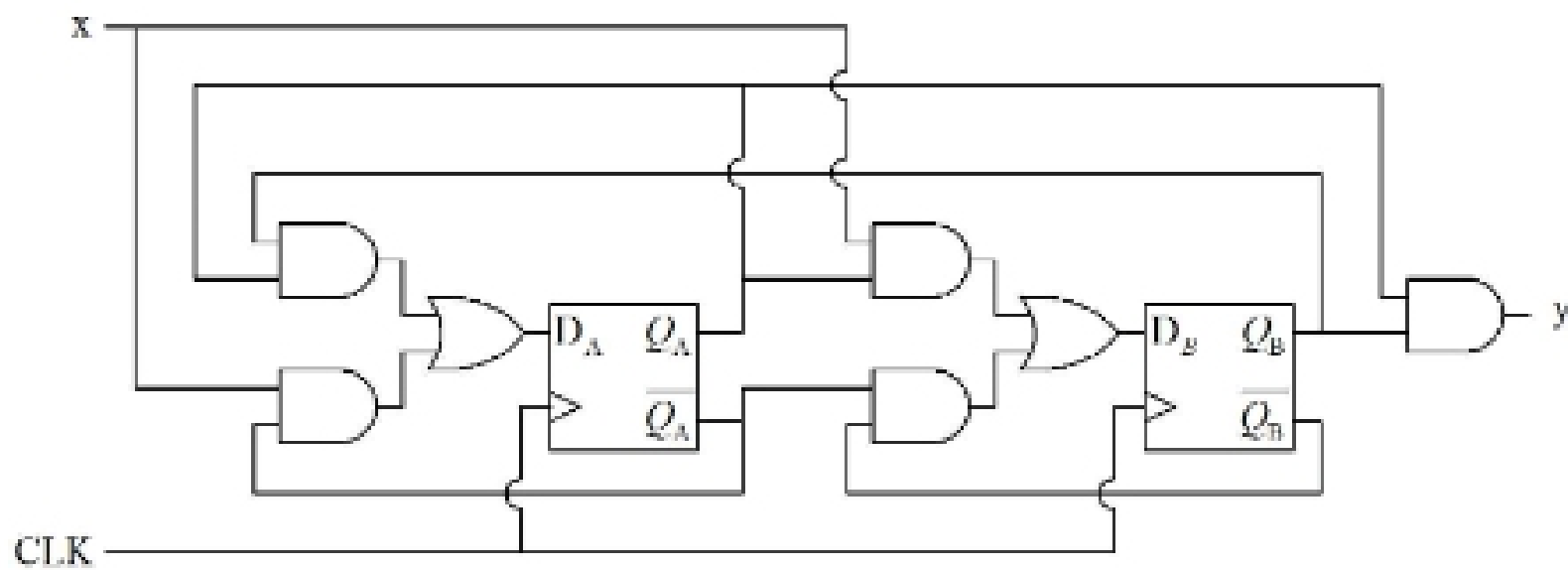

Figure 1: Discrete logic realization of a Moore finite state machine with input x and output y .

- (a) (3 points) Determine expressions for D_A , D_B , and y in terms of x , Q_A , and Q_B .

- (b) (8 points) Complete the state table in Table 1.

Present State		Next State		Output
Q_A	Q_B	x	\bar{x}	y
0	0			
0	1			
1	0			
1	1			

Table 1: State table for the Moore finite state machine in Figure 1.

2. (10 points) Table 2 shows the state table for another finite state machine, with inputs x and y , and output z . The notation xy indicates that the input x is in a logic low-state while the input y is in a logic high-state. For a given present state, input combinations that are not possible are indicated by X. Using the four-variable Karnaugh map in Figure 2, determine the excitation equation for the input D_B to the D-type flip-flop whose output is Q_B . To receive credit, mark all the minterms with either a 1, 0 or X (Don't Care) in the Karnaugh map.

Present State			Next State				Output
Symbol	Q_A	Q_B	xy	xy	xy	xy	z
S0	0	0	S0	X	S0	S0	0
S1	0	1	S0	S0	S1	S2	1
S2	1	1	S2	S1	X	X	1

Table 2: State table for a Moore finite state machine.

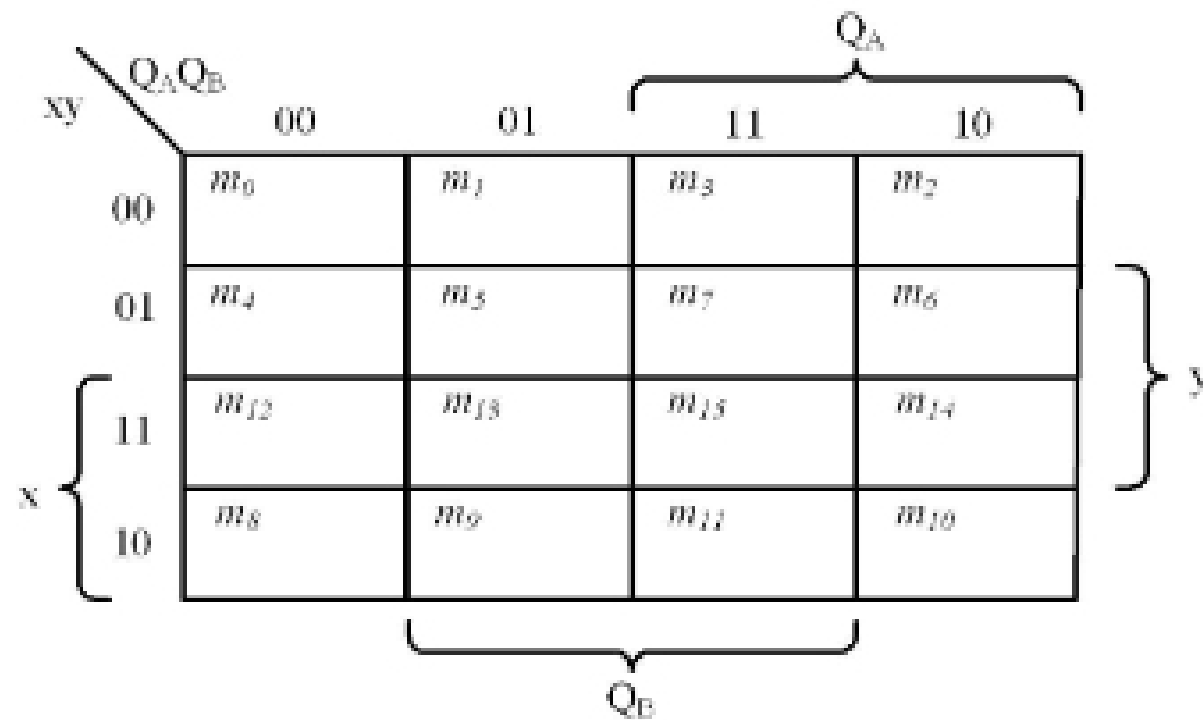

Figure 2: Four-variable Karnaugh map