

## Physics 202, Lecture 22

### Today's Topics

- Electromagnetic Waves (EM Waves)
  - Review: Waves and Wave Equation
  - Maxwell's equation
  - Propagation of **E** and **B**
  - Energy Carried by EM Wave, Poynting Vector
  - Momentum Carried by EM Wave
  - Spectrum of EM wave.

## Maxwell Equations

$$\oint \vec{E} \cdot d\vec{A} = \frac{q}{\epsilon_0} \quad \rightarrow \text{Gauss's Law/ Coulomb's Law}$$

$$\oint \vec{B} \cdot d\vec{A} = 0 \quad \rightarrow \text{Gauss's Law of Magnetism, no magnetic charge}$$

$$\oint \vec{E} \cdot d\vec{\ell} = -\frac{d\Phi_B}{dt} \quad \rightarrow \text{Faraday's Law}$$

$$\oint \vec{B} \cdot d\vec{\ell} = \mu_0 I + \epsilon_0 \mu_0 \frac{d\Phi_E}{dt} \quad \rightarrow \text{Ampere Maxwell Law}$$

Also, Lorentz force Law  $\rightarrow \vec{F} = q\vec{E} + q\vec{v} \times \vec{B}$

These are the foundations of the **electromagnetism**

## Electromagnetic Waves

□ EM wave equations:

$$\frac{\partial^2 E_x}{\partial x^2} = \mu_0 \epsilon_0 \frac{\partial^2 E_x}{\partial t^2} \quad \frac{\partial^2 B_x}{\partial x^2} = \mu_0 \epsilon_0 \frac{\partial^2 B_x}{\partial t^2}$$

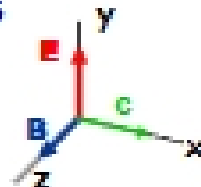

□ Plane wave solutions:

$$E = E_{\text{max}} \sin(kx - \omega t + \phi) \quad B = B_{\text{max}} \sin(kx - \omega t + \phi)$$

□ Properties:

- **No medium is necessary.**
- E and B are normal to each other
- E and B are in phase
- Direction of wave is normal to both E and B (EM waves are transverse waves)
- Speed of EM wave:  $c = \frac{1}{\sqrt{\mu_0 \epsilon_0}} = 2.9972 \times 10^8 \text{ m/s}$
- $E/B = E_{\text{max}}/B_{\text{max}} = c$
- Transverse wave: two polarizations possible

some  $\phi$ , set to be 0

## The EM Wave

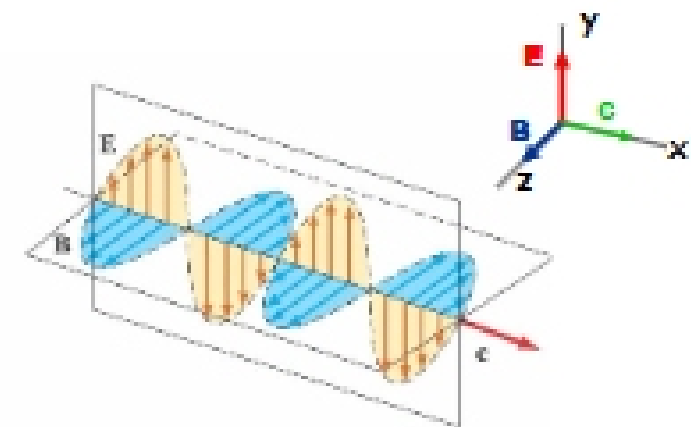

Two polarizations possible

## Wavelength and Frequency

- Because of the wave equation the wavelength of and frequency of a EM wave in vacuum are related by:

$$\lambda f = c = 3 \cdot 10^8 \text{ m/s}$$

- Example: Determine the wavelength of an EM wave of frequency 50 MHz in free space

$$\lambda = \frac{c}{f} = \frac{3 \cdot 10^8 \text{ m/s}}{50 \text{ MHz}} = \frac{3 \cdot 10^8 \text{ m/s}}{5 \cdot 10^7 \text{ s}^{-1}} = 6 \text{ m}$$

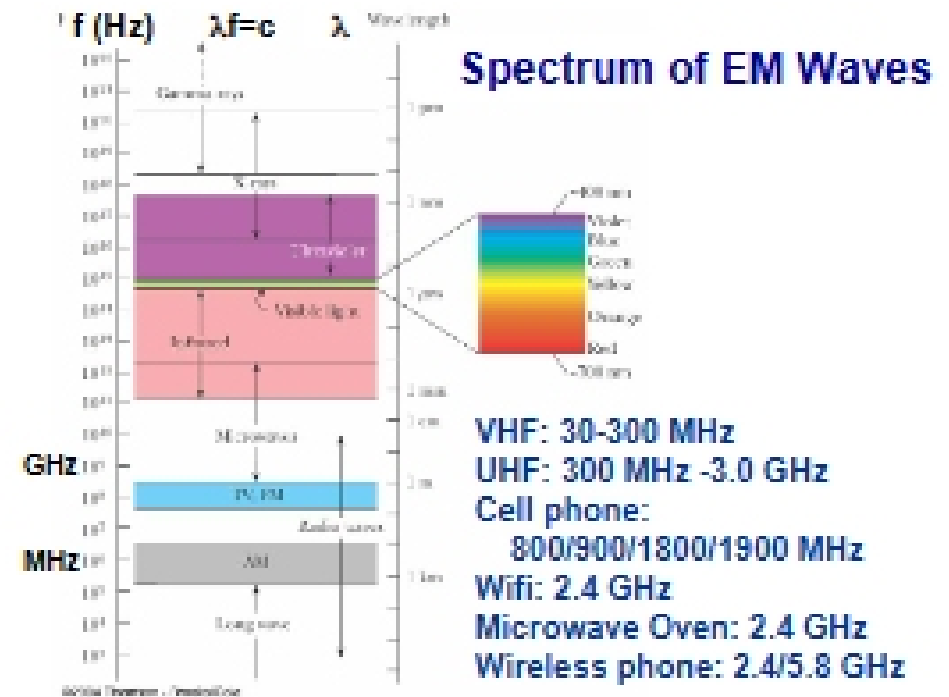

## Energy Carried By EM Waves

- Recall: energy densities  $u_E = \frac{1}{2} \epsilon_0 E^2$ ,  $u_B = \frac{1}{2} B^2/\mu_0$
- For a EM wave, at any time/location,  $u_E = \frac{1}{2} \epsilon_0 E^2 = \frac{1}{2} B^2/\mu_0 = u_B$  (using  $E/B=c$ )
- In an electromagnetic wave, the energies carried by electric field and magnetic field are always the same.

- Total energy stored (per unit of volume):  $u = u_E + u_B = \epsilon_0 E^2 = B^2/\mu_0$
- Power transmitted per unit of area is equal to  $uc$  in the direction of wave

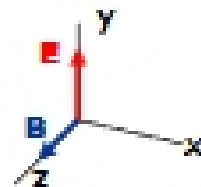

- Averaging over time:  $u_{av} = \frac{1}{2} \epsilon_0 E_{max}^2 = \frac{1}{2} B_{max}^2/\mu_0$ ,  $u_{av}c = I$  (intensity)

## The Poynting Vector

- The rate of flow of energy in an em wave is described by a vector,  $\vec{S}$ , called the Poynting vector

- The Poynting vector is defined as

$$\vec{S} \equiv \frac{1}{\mu_0} \vec{E} \times \vec{B} \quad I = S_{av}$$

- Its direction is the direction of propagation

- This is time dependent

- Its magnitude varies in time
- Its magnitude reaches a maximum at the same instant as  $E$  and  $B$

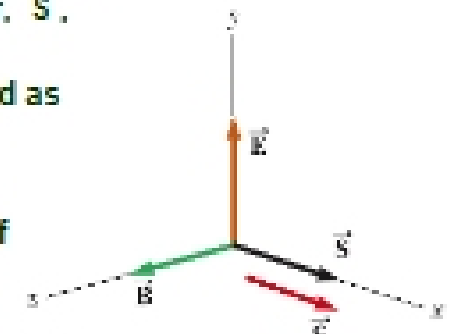

Power per unit of area

## Momentum Carried By EM Waves



- EM waves: **momentum = energy/c**

Change of momentum in 100% **absorption**  $\Delta p = \frac{\Delta U}{c} = \frac{uAc\Delta t}{c} = uA\Delta t$

Change of momentum in 100% **reflection**  $\Delta p = 2 \frac{\Delta U}{c} = 2 \frac{uAc\Delta t}{c} = 2uA\Delta t$

□ Radiation Pressure (P):  $P = \frac{F}{A} = \frac{\Delta p / \Delta t}{A} = u = \frac{S}{c}$

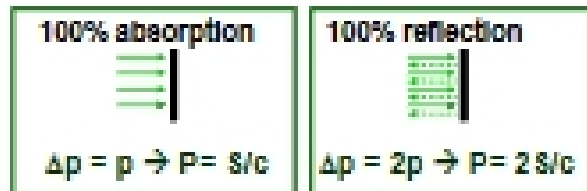

## Example: Solar Energy

- The average intensity of the EM radiation from the Sun on Earth is  $S \sim 10^3 \text{ W/m}^2$

- What is the average radiation pressure for 100% absorption:

$$P = \frac{S}{c} = \frac{10^3 \text{ W/m}^2}{3 \cdot 10^8 \text{ m/s}} = 3.3 \cdot 10^{-6} \text{ N/m}^2$$

- What is the force exerted by EM radiation by the Sun on a surface of 1 m<sup>2</sup>

$$F = PA = 3.3 \cdot 10^{-6} \text{ N/m}^2 \cdot 1 \text{ m}^2 = 3.3 \cdot 10^{-6} \text{ N}$$

## Antennas

- Antennas are essentially arrangement of conductors for transmitting and receiving radio waves.
- Parameters: gain, impedance, frequency, orientation, polarization, etc.

