

Lecture 24

- Last time:
 - Multi-stage amplifiers: voltage, transconductance
- Today :
 - Cascode: merged CS/CG cascade

CG Cascade: Sharing a Supply

First stage has no current supply of its own \rightarrow its output resistance is modified

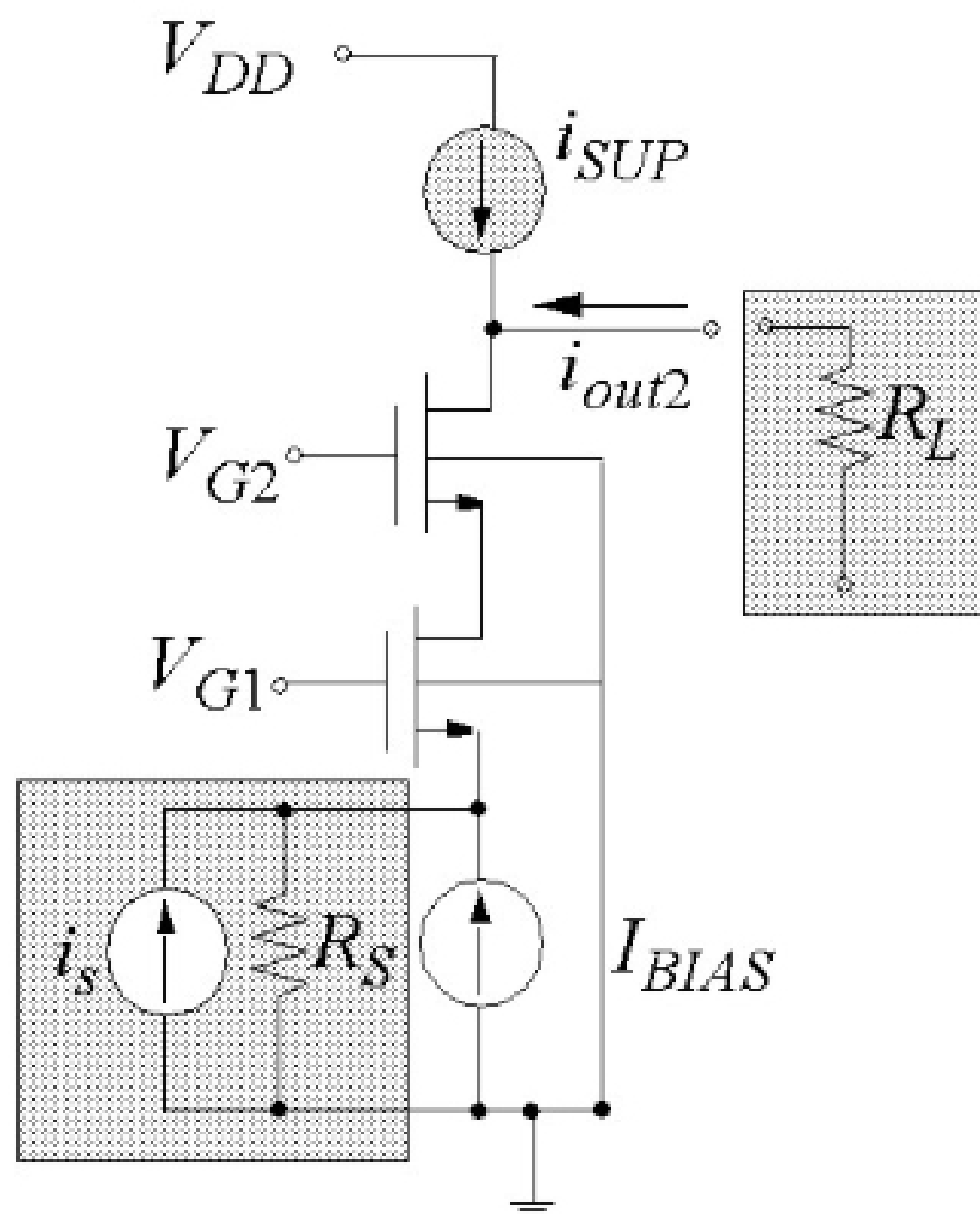

Multistage Amplifier Design Examples

Start with basic two-stage transconductance amplifier:

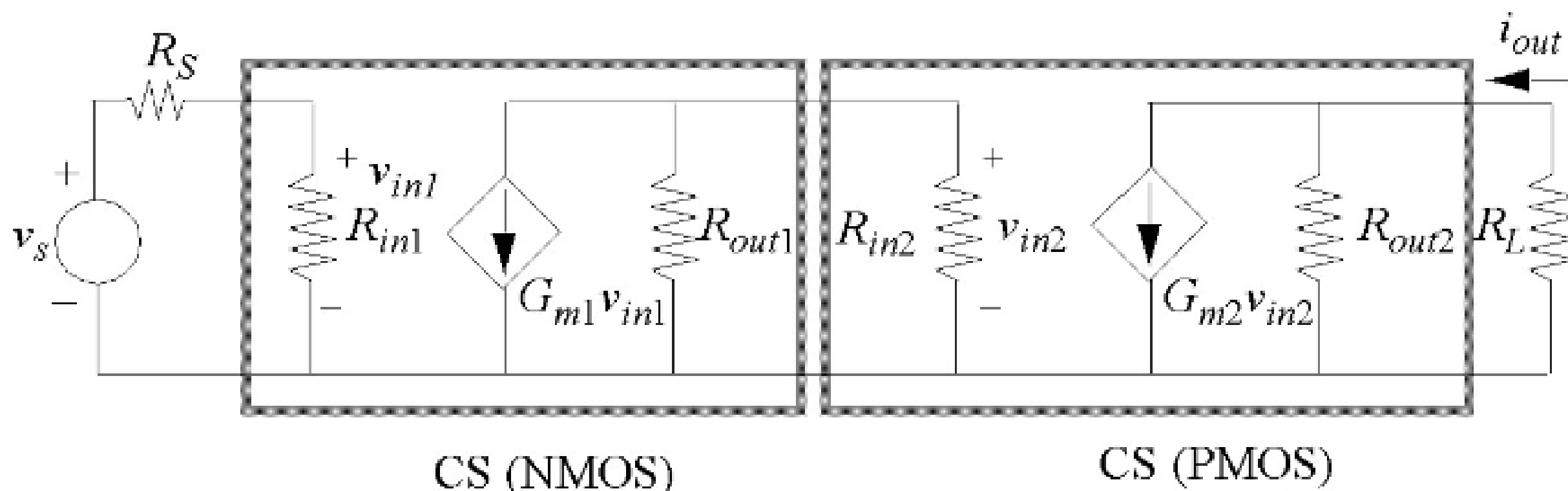

Why do this combination?