

MASSACHUSETTS INSTITUTE OF TECHNOLOGY
 Department of Electrical Engineering and Computer Science
 6.01—Introduction to EECS I
 Spring Semester, 2008
 Week 8 Course Notes

Op-Amps

Op Amps

So far, we have considered circuits with resistors and voltage sources. Now we are going to introduce a new component, called an *operational amplifier* or op-amp, for short. We are studying op-amps because they are a very important circuit element, as well as because they will allow us to explore a sequence of models of how they work. These models vary in complexity and fidelity. The simplest is the easiest to use for basic circuit designs, but doesn't capture some important behavioral properties. The more complex models give us a more complete picture, but are often unnecessarily complicated. There is no right model of an op-amp: it all depends on the question that you are trying to answer.

Basic model

Figure 1(a) shows a diagram of our simplest op-amp model. The basic behavioral model is that it adjusts v_{out} in order to try to maintain the constraint that $v_+ \approx v_-$ and that no current flows in to n_+ or n_- .

The best way to understand why we might want such a device is to see how it behaves in some small circuit configurations.

Non-inverting amplifier Not surprisingly, a primary use of an op-amp is as an amplifier. Here is an amplifier configuration, shown in figure 1(b). Let's see if we can figure out the relationship between v_{in} and v_{out} . The circuit constraints tell us that

$$v_- = i_I R_I \quad (1)$$

$$v_- - v_{\text{out}} = i_I R_F \quad (2)$$

$$-i_I - i_I = 0 \quad (3)$$

$$v_{\text{in}} = v_- \quad (4)$$

The KCL equation 3 has no term for the current into the op-amp, because we assume it is zero. Equation 4 is the op-amp constraint. So, we find that

$$v_{\text{out}} = v_{\text{in}} \frac{R_F + R_I}{R_I} .$$

This is cool. We've arranged for the output voltage to be greater than the input voltage, and we can arrange just about any relationship we want, by choosing values of R_F and R_I .

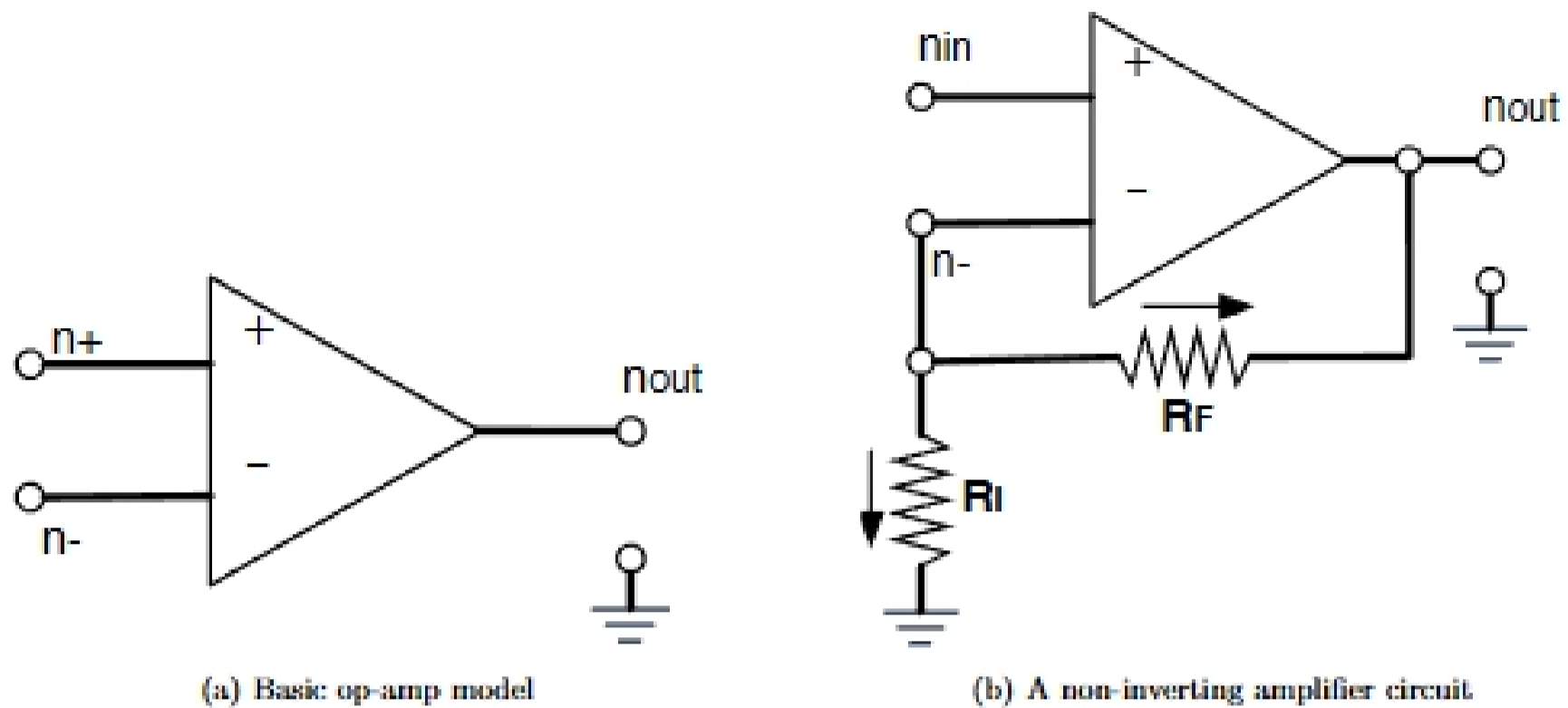

Figure 1: Basic op-amp model; non-inverting amplifier

We can think intuitively about how it works by examining some cases. First, if $R_F = 0$, then we'll have $v_{out} = v_{in}$, so there's not a particularly interesting change in the voltages. This is still a useful device, called a *voltage follower*, which we'll study a bit later.

Now let's think about a more interesting case, but simplify matters by setting $R_F = R_I$. We can look at the part of the circuit running from V_{out} through R_F and R_I to ground. This looks a lot like a voltage divider, with v_- coming out of the middle of it. Because v_- needs to be the same as v_{in} , and it is v_{out} being divided in half, then v_{out} clearly has to be $2v_{in}$.

Inverting amplifier Figure 2(a) shows a very similar configuration, called an *inverting amplifier*. The difference is that the $+$ terminal of the op-amp is connected to ground, and we're thinking of the path through the resistors as the terminal of the resulting circuit. Let's figure out the

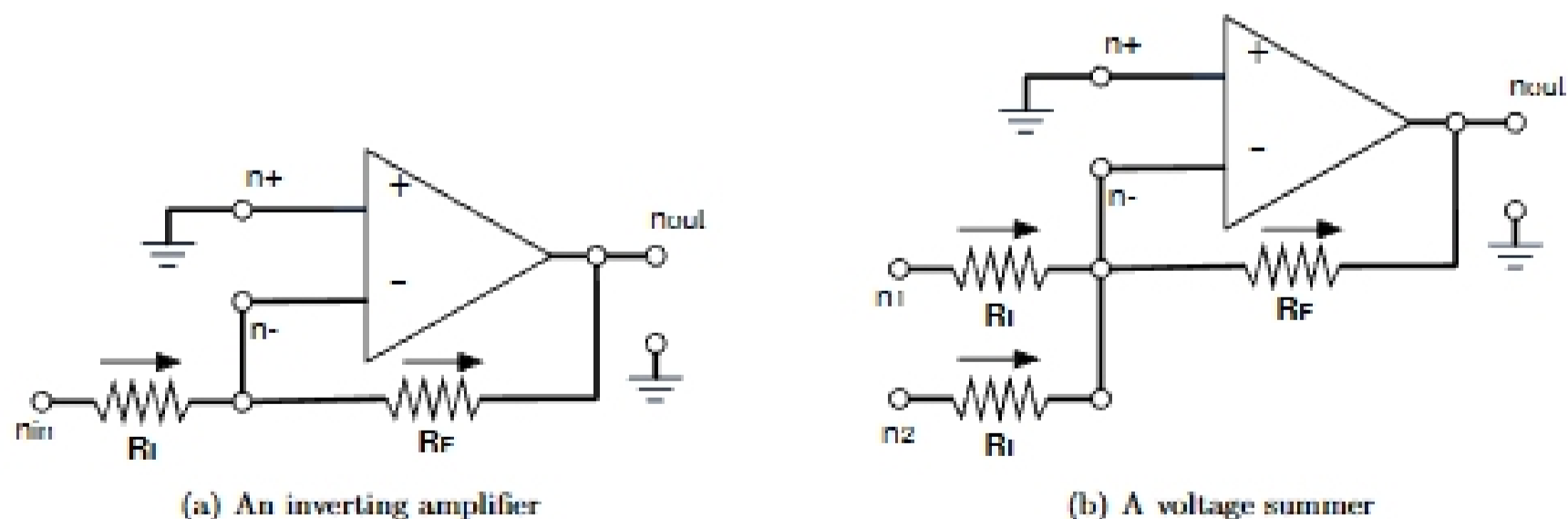

Figure 2: Inverting amplifier; summer

relationship between v_{in} and v_{out} for this one. The circuit constraints tell us that

$$\begin{aligned} v_{in} - v_- &= i_I R_I \\ v_- - v_{out} &= i_F R_F \\ i_I - i_F &= 0 \\ v_+ &= v_- \\ v_+ &= 0 \end{aligned}$$

Solving, we discover that

$$v_{out} = -v_{in} \frac{R_F}{R_I} .$$

If $R_F = R_I$, then this circuit simply inverts the incoming voltage. So, for example, if v_{in} is +10V with respect to ground, then v_{out} will be -10V. Again, we can see the path from n_{in} through the resistors, to n_{out} , as a voltage divider. Knowing that v_- has to be 0, we can see that v_{out} has to be equal to $-v_{in}$. If we want to scale the voltage, as well as invert it, we can do that by selecting appropriate values of R_F and R_I .

Voltage summer A *voltage summer*¹ circuit, as shown in figure 2(b), can be thought of as having three terminals, with the voltage at n_{out} constrained to be a scaled, inverted, sum of the voltages at n_1 and n_2 . You should be able to write down the equations for this circuit, which is very similar to the inverting amplifier, and derive the relationship:

$$v_{out} = -\frac{R_F}{R_I} (v_1 + v_2) .$$

Voltage follower Figure 3(a) shows a basic *voltage follower* circuit. What will it do? We can see from basic wiring constraints that:

$$\begin{aligned} v_+ &= V_c \\ v_{out} &= v_- \end{aligned}$$

Adding in the op-amp constraint that $v_+ = v_-$, then we can conclude that $v_{out} = V_c$. So, we've managed to make a circuit with the same voltage at n_{out} as at the positive terminal of the voltage source. What good is that? We'll see in the next section.

Voltage-controlled voltage-source model

Let's start by thinking about using a variable voltage to control a motor. If we have a 15V supply, but only want to put 7.5V across the motor terminals, what should we do? A voltage divider seems like a good strategy: we can use one with two equal resistances, to make 7.5V, and then connect it to the motor as shown in figure 3(b). But what will the voltage v_{motor} end up being? It all depends on the resistance of the motor. If the motor is offering little resistance, say 100Ω, then the voltage v_{motor} will be very close to 0.² So, this is not an effective solution to the problem of supplying 7.5V to the motor.

¹As in thing that sums, not as in endless summer.

²Go back and review the discussion of adding a load to a voltage divider, if this doesn't seem clear.