

The Internet: Packet Switching and Other Big Ideas

Ian Foster

The Internet

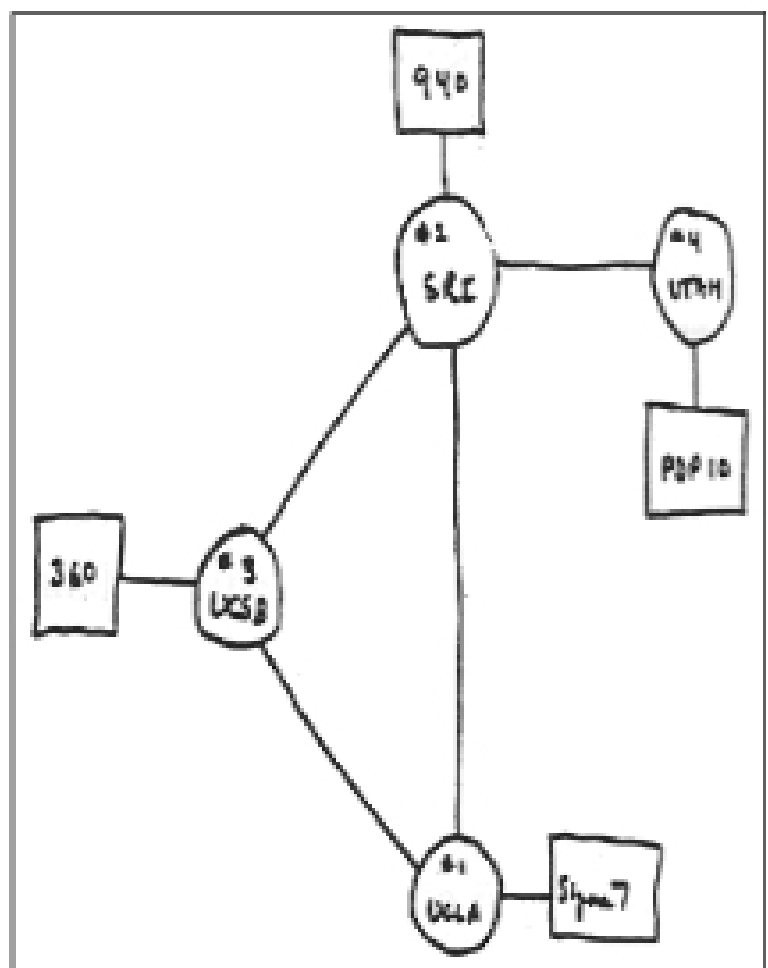

1969
4 nodes

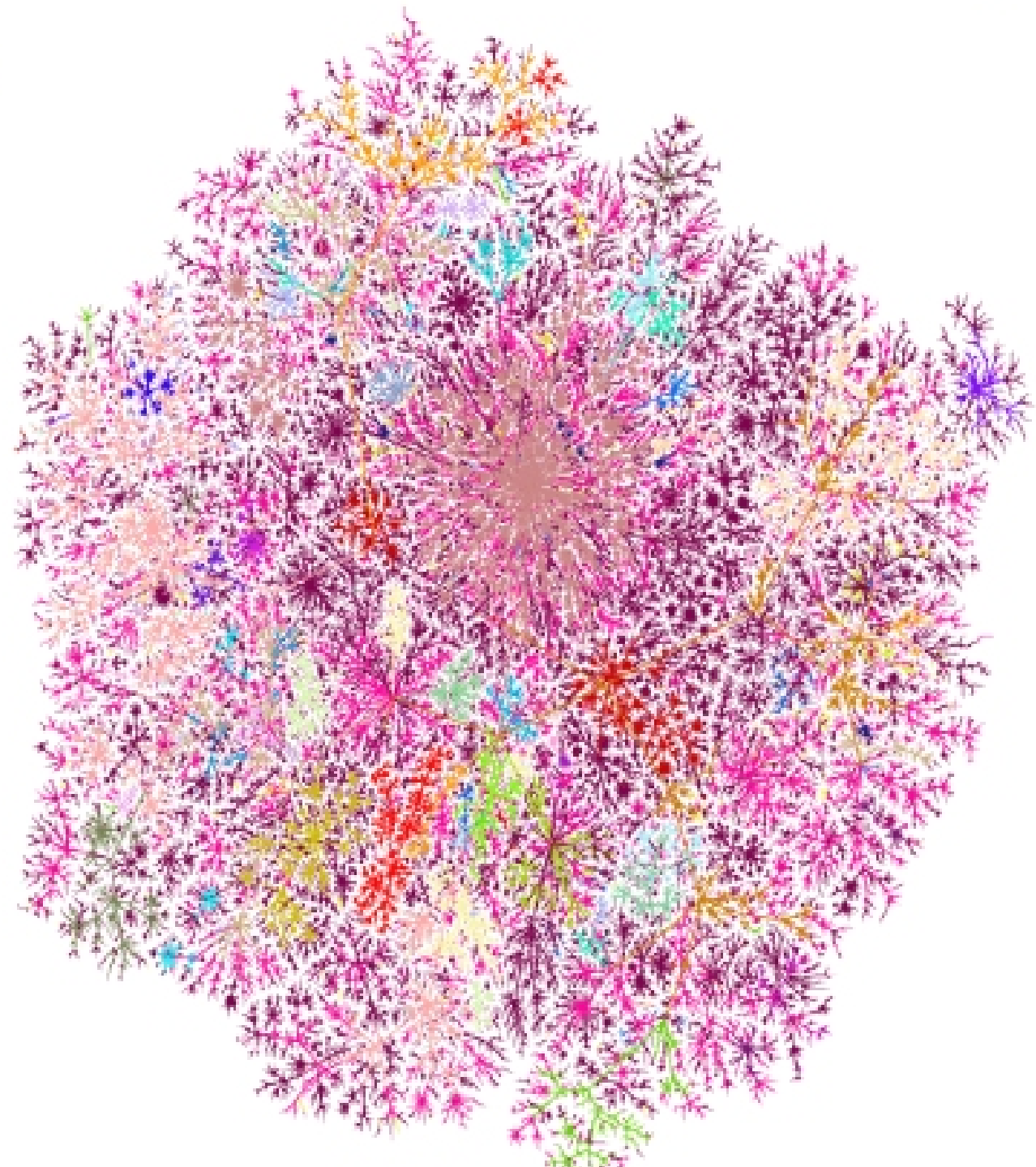

2004
100s of millions

The Internet

- Clearly a huge success in terms of not only impact but also scalability
 - ◆ Some (not all) of the basic notions have scaled over eight orders of magnitude
- What were underlying big ideas? Let's say:
 - ◆ Packet switching
 - ◆ End-to-end principle
 - ◆ Internet community & "standards" process
- Also other important algorithms, e.g.
 - ◆ Routing, naming, multicast
- Common thread: (fairly) robust emergent behaviors from simple local strategies