

Read: Ch. 16 in *Electric Circuits, 9th Edition* by Nilsson

Circuit Analysis with periodic waveform inputs

Key: After representing the periodic waveform with a Fourier series, use superposition and standard AC circuit analysis (phasor analysis). Each harmonic must be handled separately since the impedance of each L and C changes with frequency.

Example: Determine the RMS value of the capacitor voltage, $v(t)$, in the circuit shown below. The input voltage, $V_s(t)$, is an infinite periodic 0 to 10V ramp waveform.

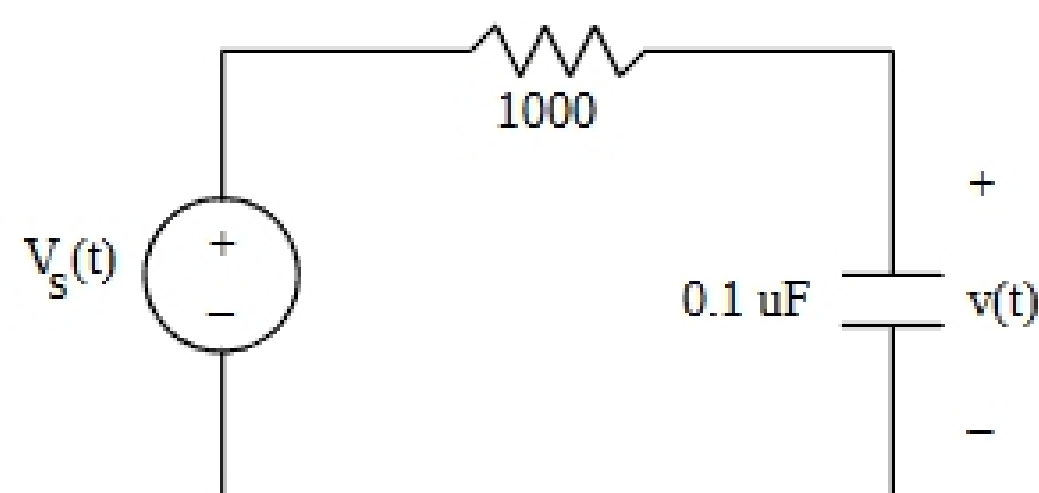
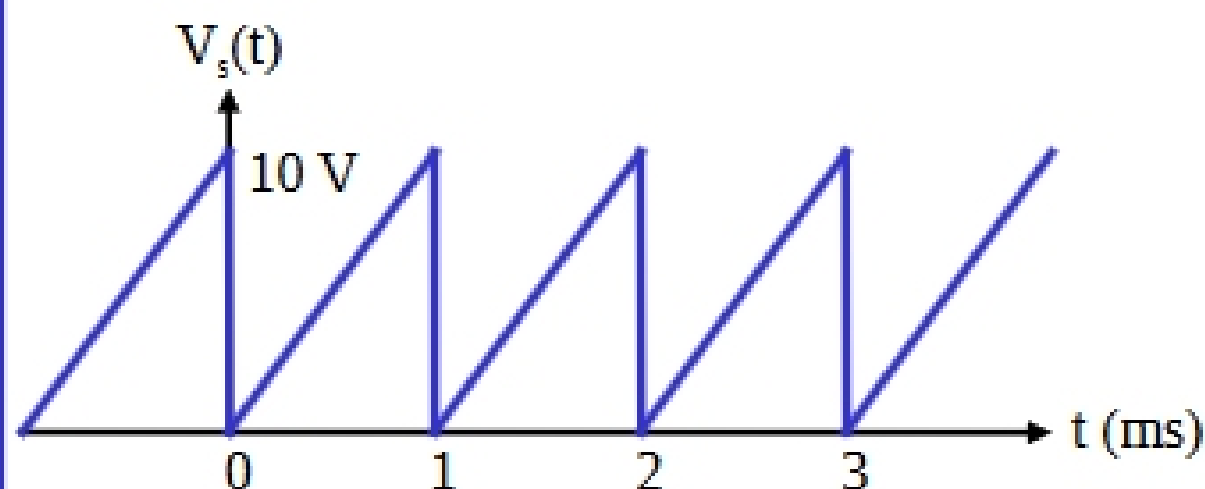

First, find the Fourier series for $V_s(t)$:

$$V_s(t) = 5 - \frac{10}{\pi} \sin(2000\pi t) - \frac{10}{2\pi} \sin(4000\pi t) - \frac{10}{3\pi} \sin(6000\pi t) - \frac{10}{4\pi} \sin(8000\pi t) - \dots$$

Lecture #20 EGR 261 – Signals and Systems

We can now replace the ramp voltage source in the circuit by an infinite number of sinusoidal voltage sources as shown below:

$$V_s(t) = 5 - \frac{10}{\pi} \sin(2000\pi t) - \frac{10}{2\pi} \sin(4000\pi t) - \frac{10}{3\pi} \sin(6000\pi t) - \frac{10}{4\pi} \sin(8000\pi t) - \dots$$

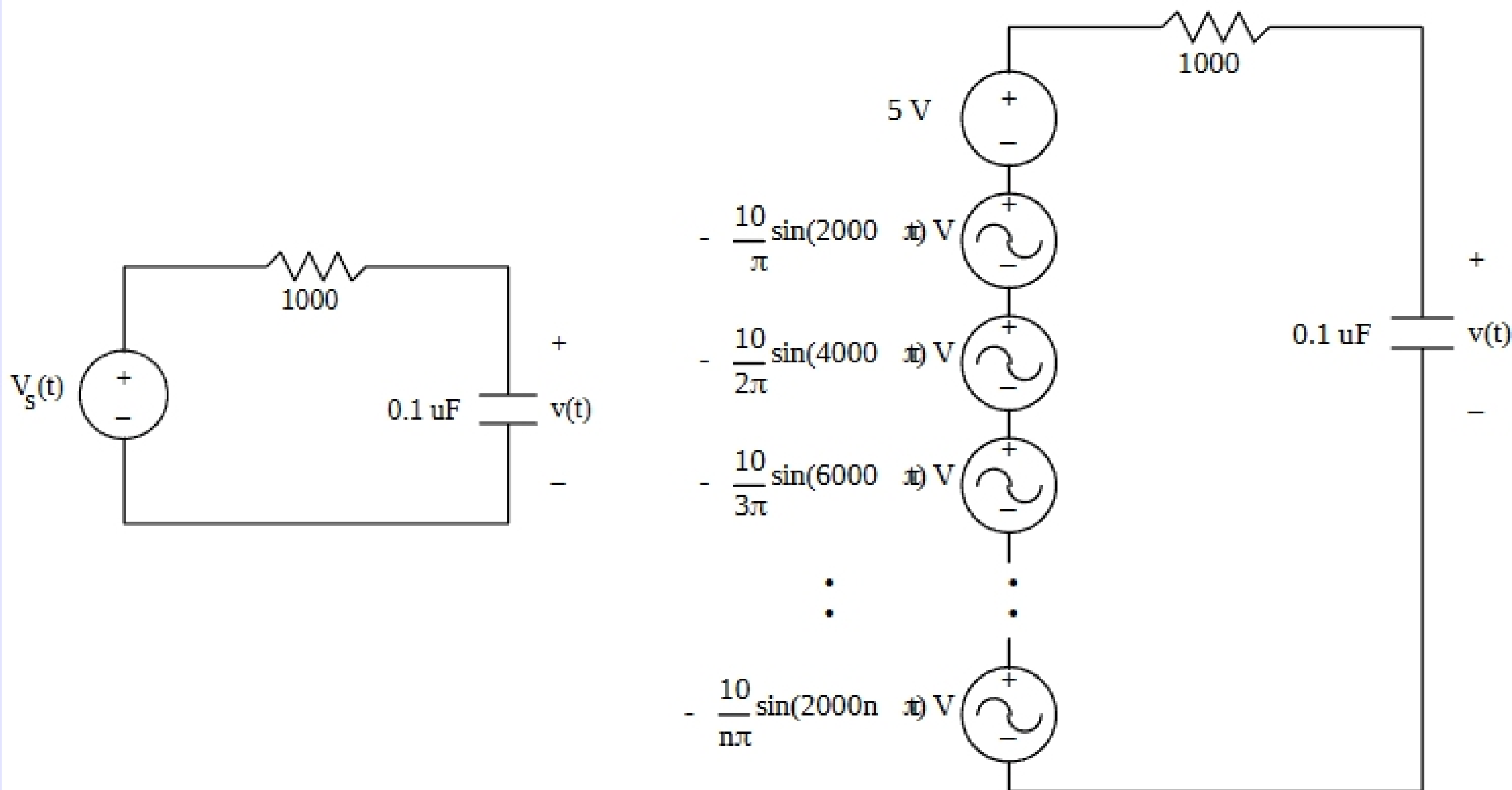

Lecture #20 EGR 261 – Signals and Systems

Now using superposition the circuit can be analyzed once for each source with all other sources killed (shorted). Note that the capacitor impedance changes for each circuit.

DC source only:

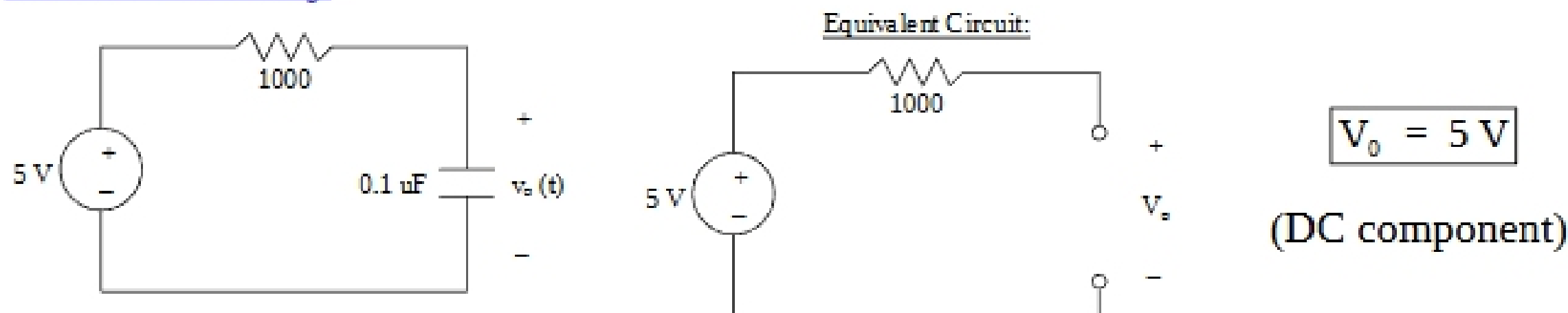

First harmonic source only:

