

Lab Reference Sheets

This document contains useful information for constructing and testing digital logic circuits, including:

- **Pinouts**
- **Data sheets**
- **Capacitor markings and values available in lab**
- **Standard 5% and 10% Resistor and the resistor color code**
- **SK-10 breadboard and an example circuits wired on the breadboard**
- **Building a 5V power supply using a 9V battery and a 5V regulator**

This document is available from the instructor's web page in both Adobe Acrobat format and in Microsoft Word format. If you download the Microsoft Word file, you can copy any of the pinout or other information that you wish into lab reports or other locations.

The Drawing Tools in Microsoft Word were used to create the pinouts and circuits. The Drawing Tools menu usually appears at the bottom of the screen in Word. If it does not, pick *View - Toolbars - Drawing* from the menu. Each pinout has been grouped so that it can be easily moved and resized. To edit a pinout, select the object and then pick *Draw - Ungroup* from the Drawing Tools menu.

Data Sheets

Data sheets for the devices listed below, along with a number of other devices, are available on the instructor's web page.

- 7400 – Quad 2-input NAND
- 74HC00 – CMOS Quad 2-input NAND
- 7401 – Open-collector Quad 2-input NAND
- 7406/7416 – Open-collector inverter
- 7447A – BCD-to-7-segment-decoder/driver (for common anode displays)
- 7476– JK flip-flop with Preset and Clear
- 74151 – 8x1 multiplexer (data selector)
- 74155/74156 – Dual 2x4 decoder
- 74191 – Synchronous 4-Bit Up/Down Counter
- 555 – Timer
- GAL22V10 – Programmable Logic Device (PLD)

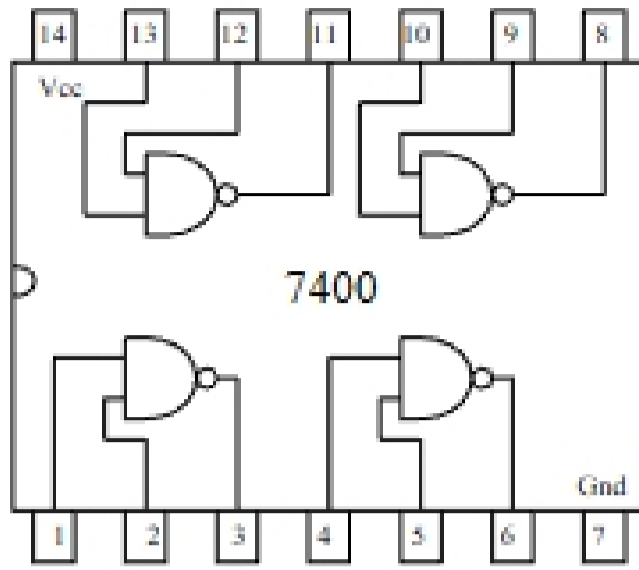

7400 Quad 2-input NAND

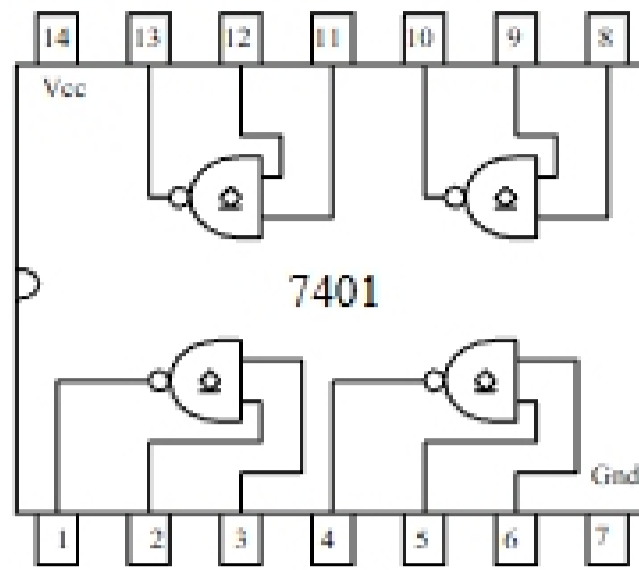

7401 Quad 2-input NAND
(open-collector outputs)

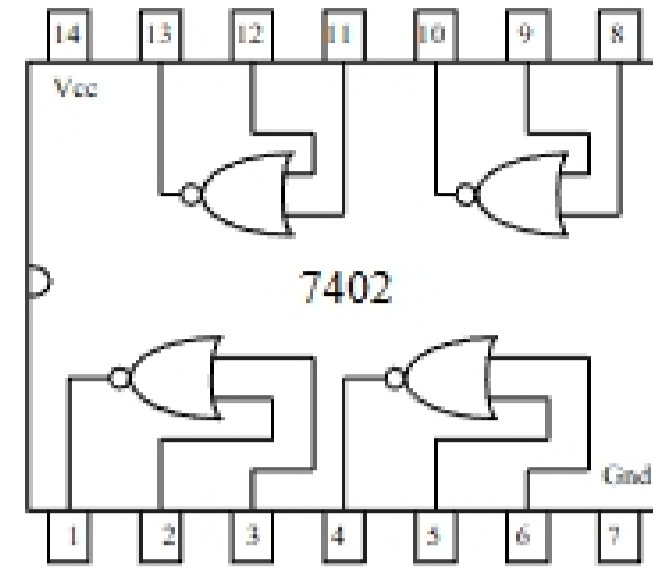

7402 Quad 2-input NOR

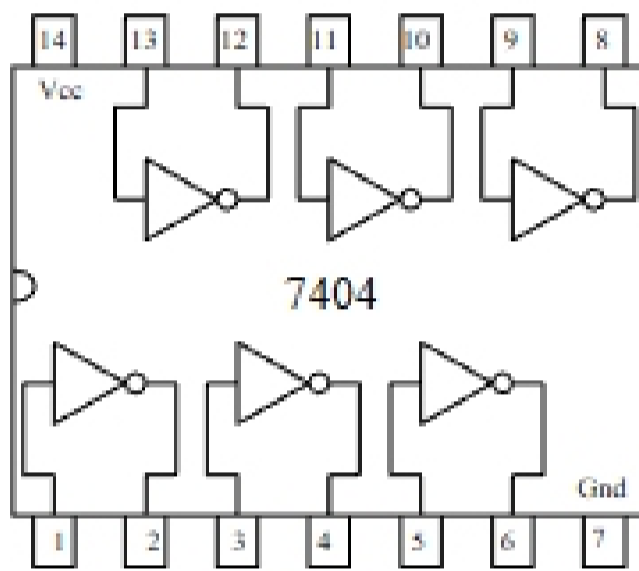

7404 Hex Inverter

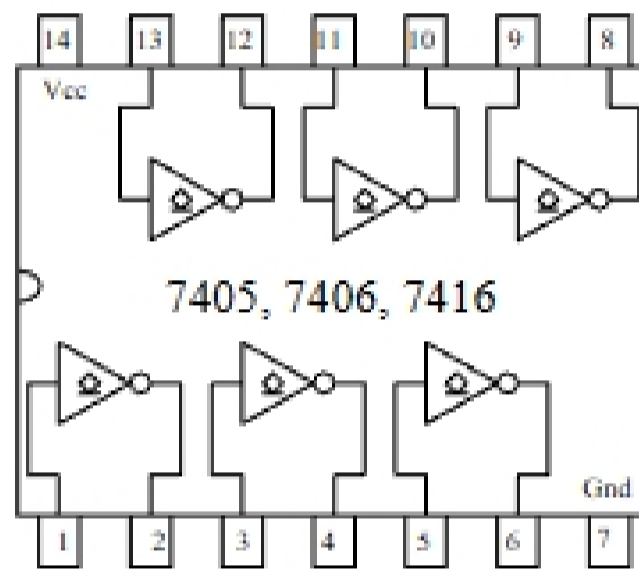

7405, 7406, 7416 Hex Inverter
(open-collector outputs)

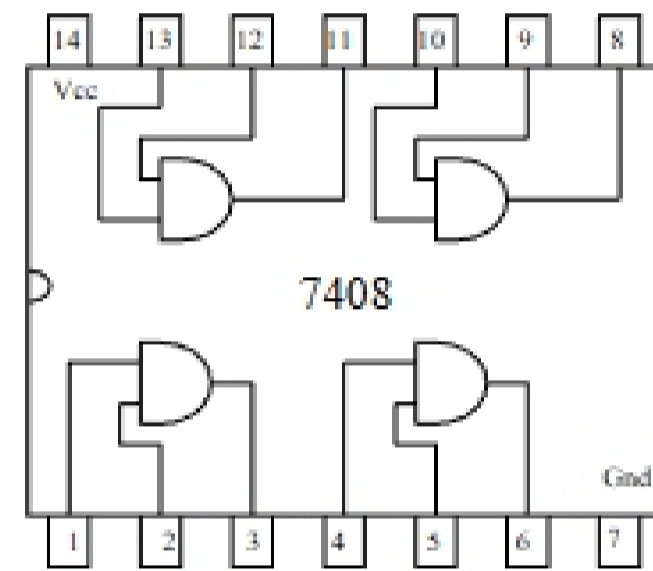

7408 Quad 2-input AND

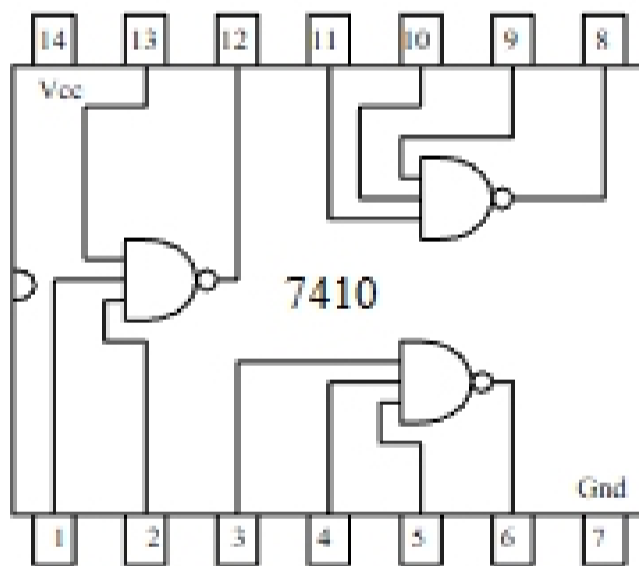

7410 Triple 3-input NAND

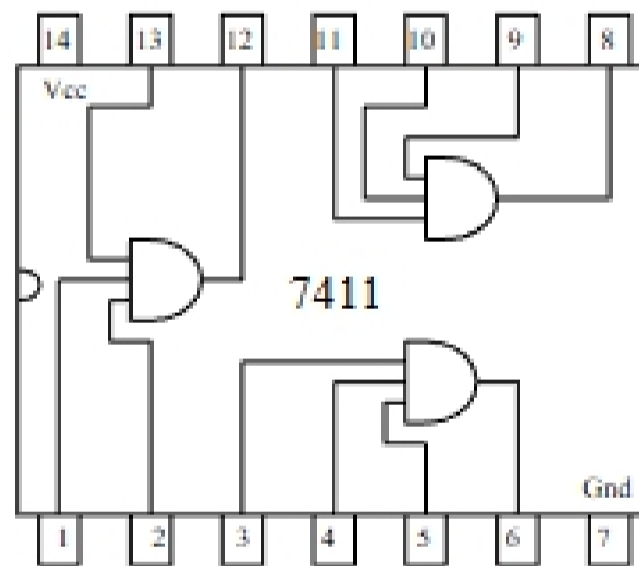

7411 Triple 3-input AND

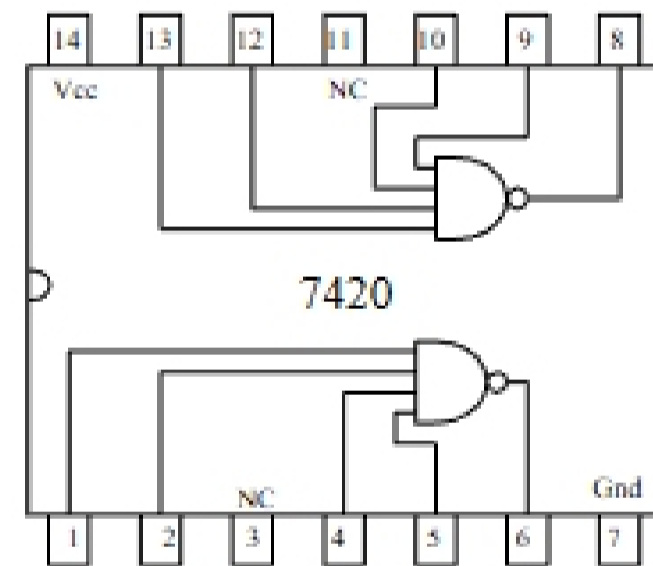

7420 Dual 4-input NAND

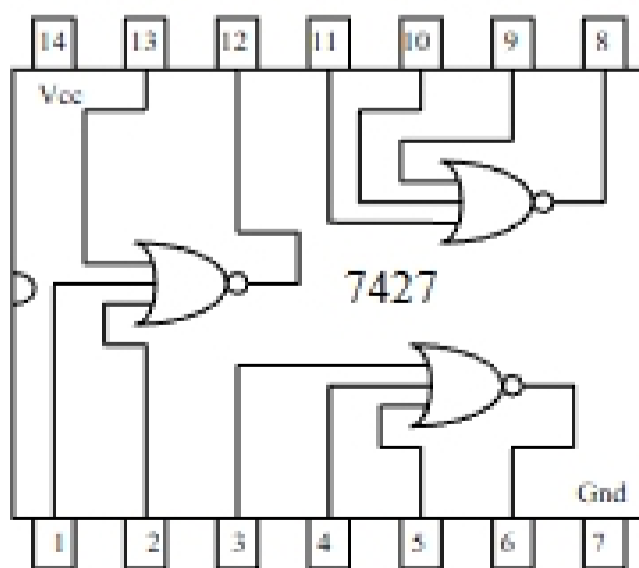

7427 Triple 3-input NOR

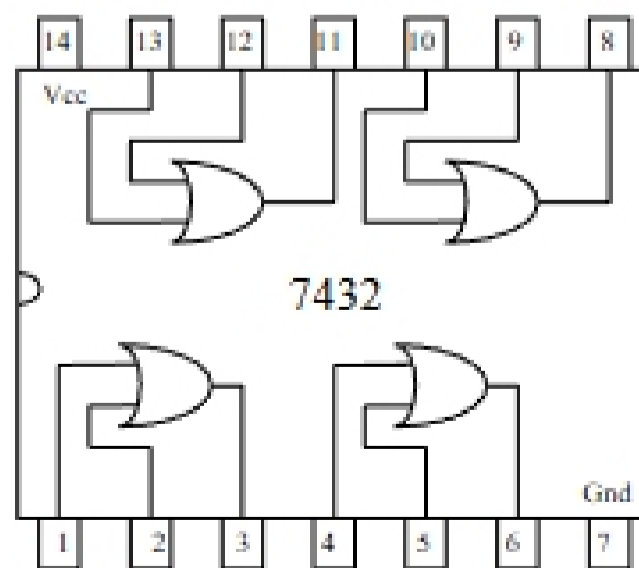

7432 Quad 2-input OR

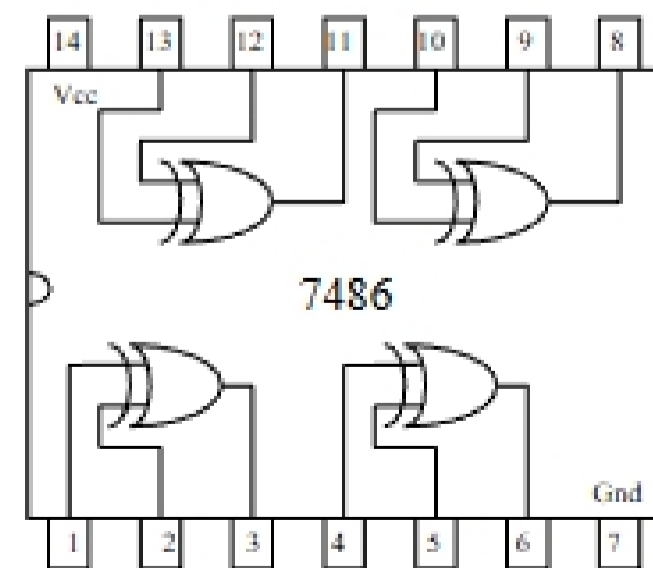

7486 Quad 2-input Exclusive-OR

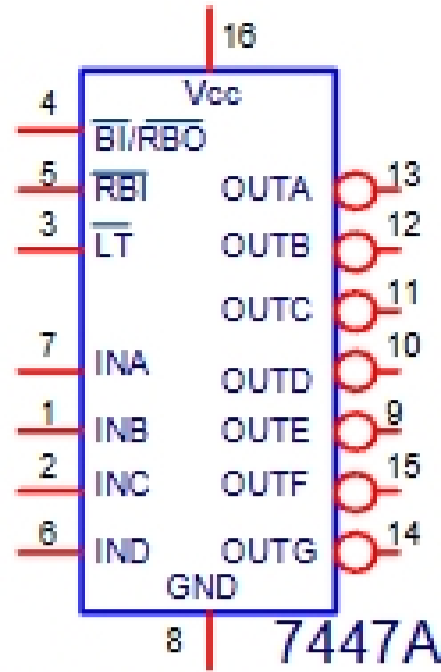
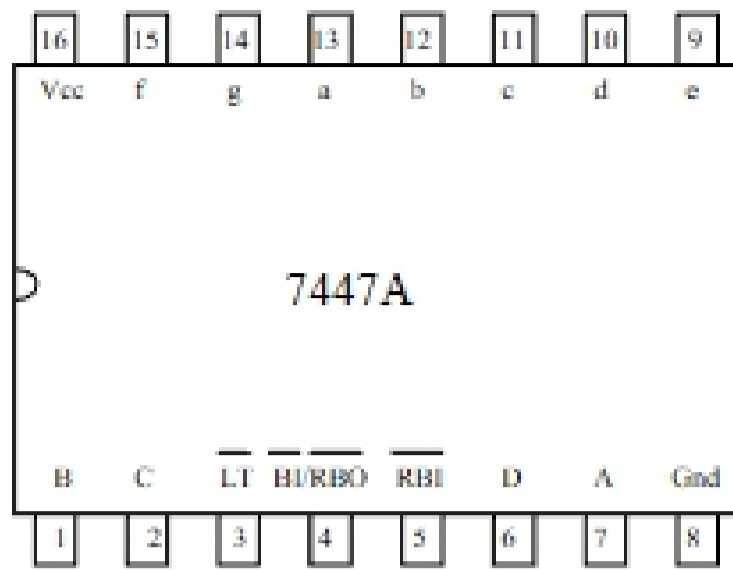

7447A BCD to 7-segment decoder/driver: Pinout and Logic Symbol

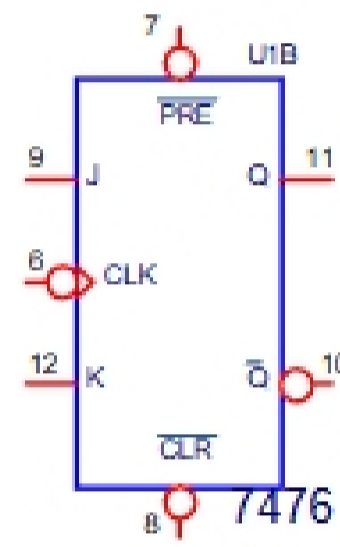
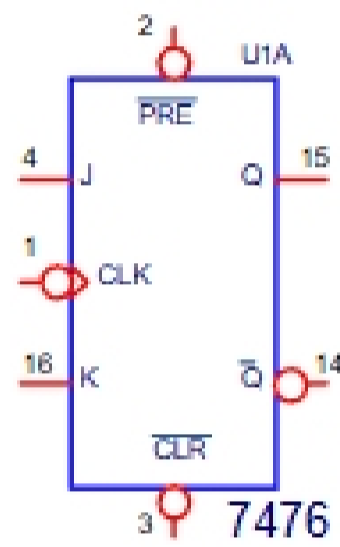
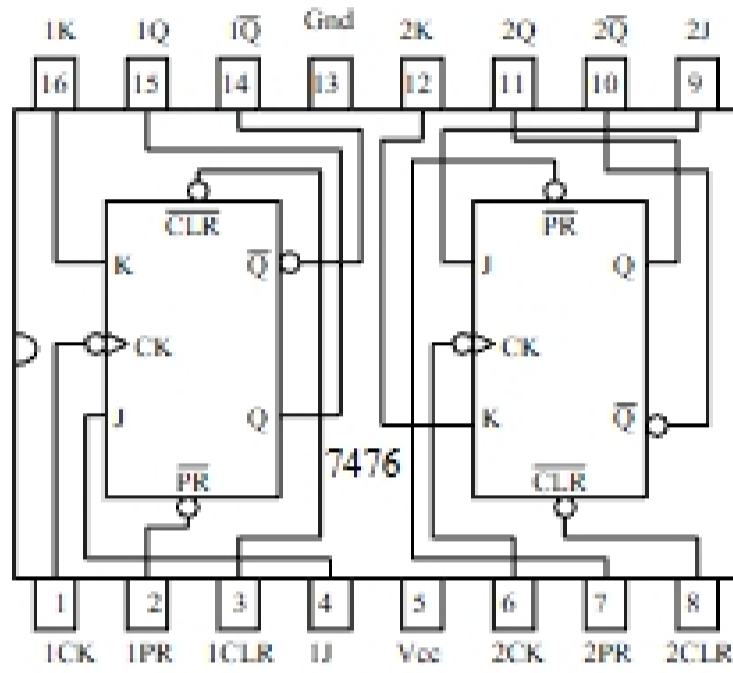

7476 Dual JK Flip-Flop: Pinout and Logic Symbols

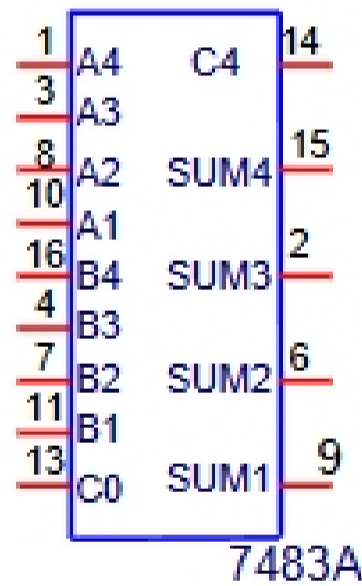
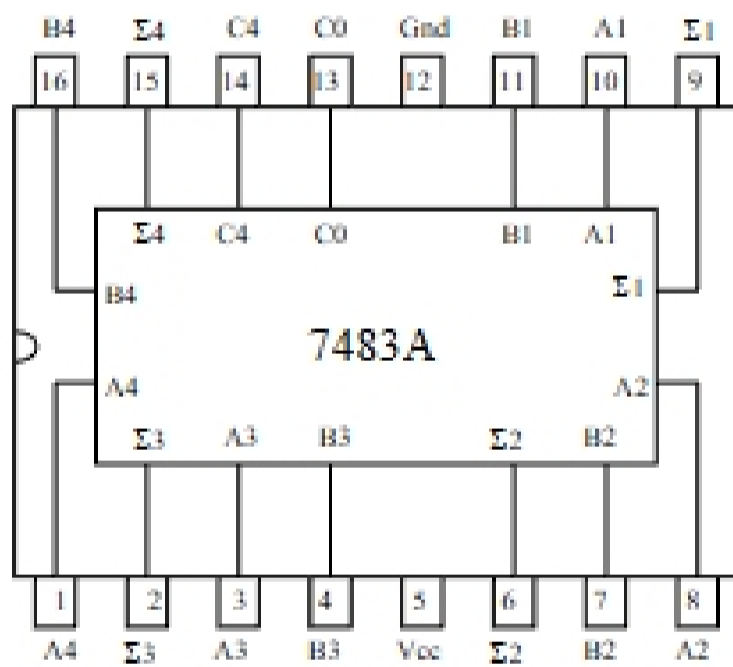

7483A 4-bit Adder: Pinout and Logic Symbol

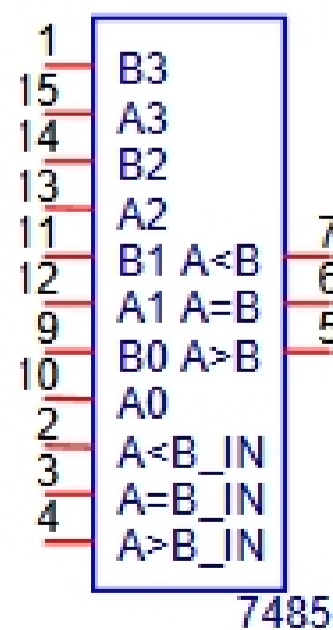
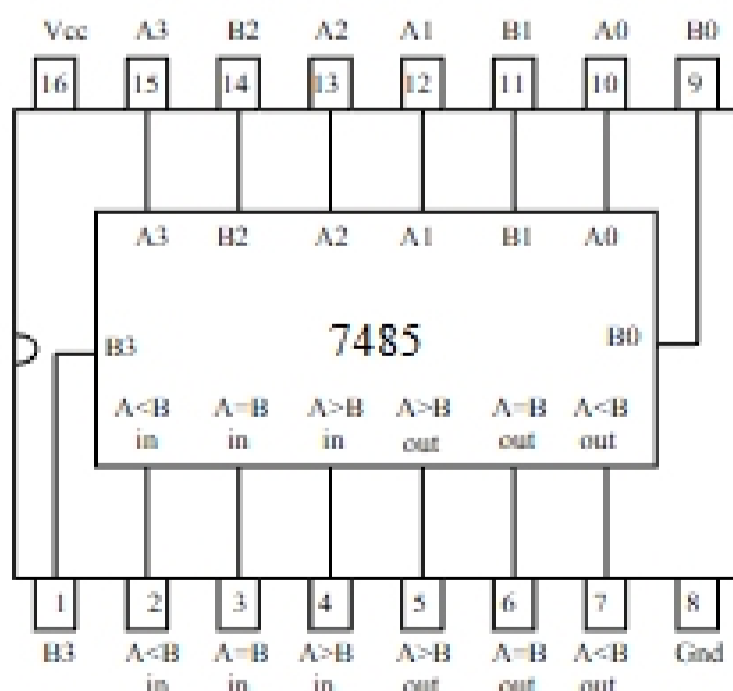

7485 4-bit Magnitude Comparator: Pinout and Logic Symbol