

Last Name (Print): _____

First Name (Print): _____

ID number (Last 4 digits): _____

Section: _____

Submission deadlines:

- Each EE 200 student must complete the circuits in problem 37 prior to attending Laboratory #20. At the beginning of Laboratory #20, each student must show the completed circuit to the instructor to receive a grade for problem 37.
- Demonstrate completion of problem 38 during the evening laboratory session on either Monday March 31 or Tuesday April 1 from 6:30 pm to 8:30 pm in 302 EE West. You must sign up for a ten minute slot using SignUpGenius. You will receive an email message via your Penn State email address when the sign up sheet is available online at SignUpGenius. Slots are filled on a first-come, first-served basis.
- Turn in the written solutions for problems 39 and 40 by 4:00 pm on Tuesday April 1 in the homework slot outside 121 EE East.

Problem	Weight	Score
37	20	
38	30	
39	25	
40	25	
Total	100	

Problem 37: (20 points)

A goal of Laboratory #20 is to read the angular displacement of a mechanical encoder using the dsPIC33EP64MC502 microcontroller using the C programming language and the myDAQ using the LabVIEW programming environment. You will also realize a LED dimmer system that utilizes the mechanical encoder along with the microcontroller. Every EE 200 student must construct the circuits in Figures 1 and 2 and bring them to Laboratory #20. Details for completing the microcontroller interface circuit in Figure 1 are available in Problem Set 7 Problem 25. To avoid contact bounce producing undesirable changes in the encoder count, the circuit in Figure 2 incorporates two $0.01 \mu\text{F}$ capacitors, that in conjunction with the $27 \text{ k}\Omega$ resistors, form low-pass filters that attenuate the multiple pulses resulting from contact bounce. **The $0.01 \mu\text{F}$ capacitors are not contained in the EE 200 Component Kit and will be distributed by the instructor at the start of Laboratory #20.** Identify the terminals A, B, and C of the mechanical encoder using the specification sheet, Bourns_encoder.pdf, included with Problem Set 10.

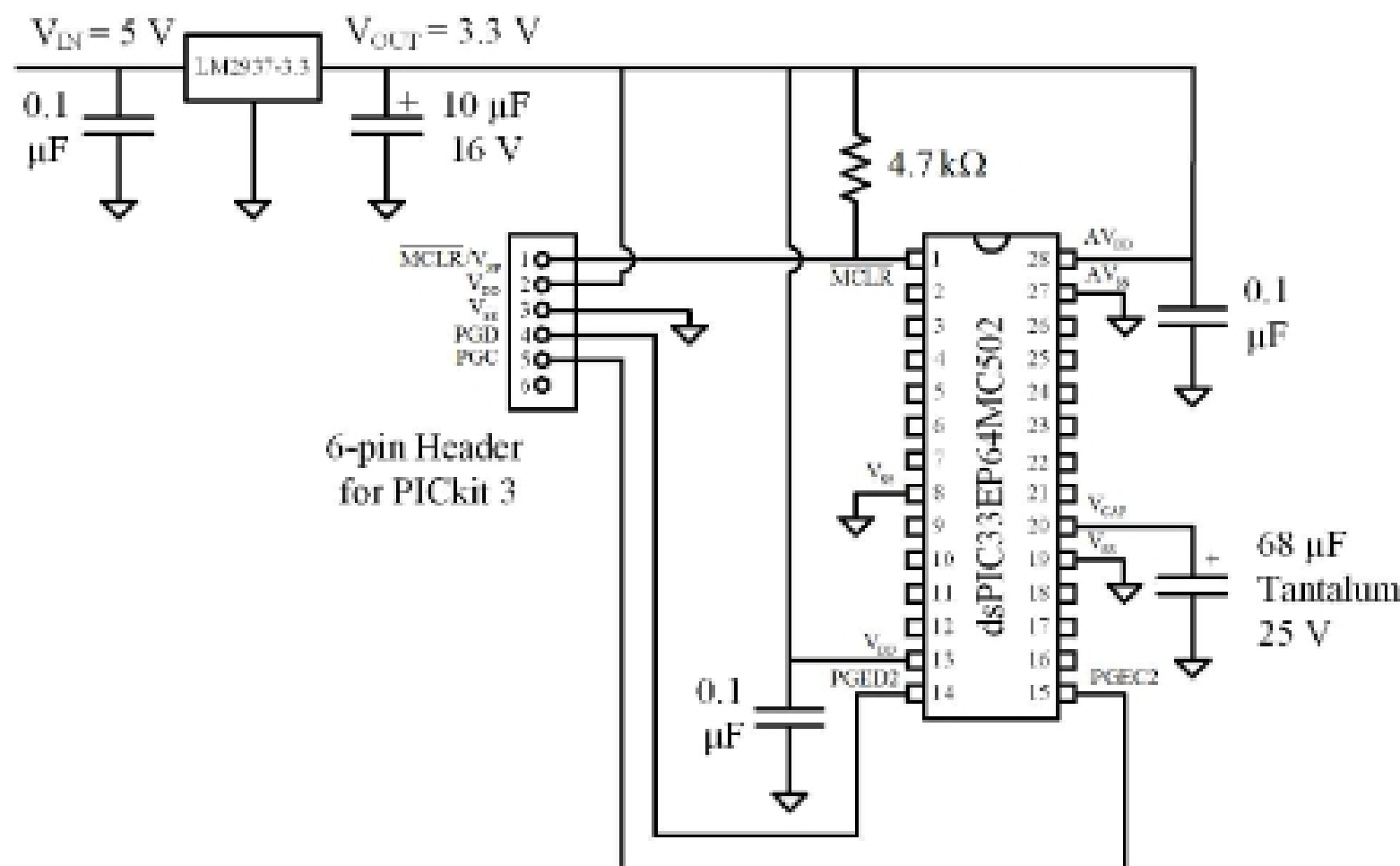

Figure 1: Basic connections for all EE 200 microcontroller exercises.

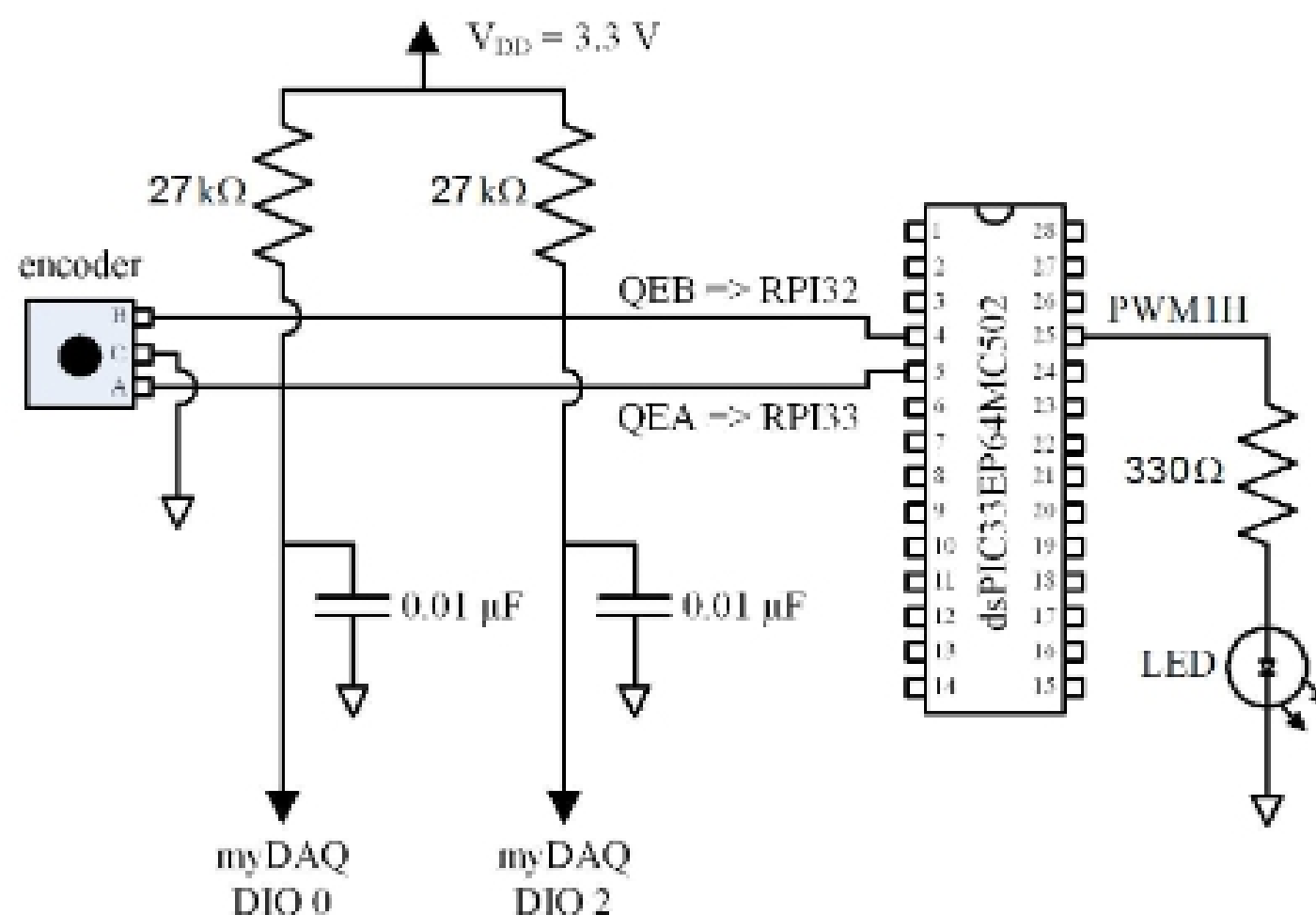

Figure 2: Additional circuit connections required for Laboratory #20.

Problem 38: (30 points)

Each EE 200 student must realize the finite state machine for robot navigation introduced in Problem Set 3 Problem 10 using the dsPIC33EP64MC502 microcontroller, and demonstrate their circuit to the laboratory instructor during the grading session on either Monday March 31 or Tuesday April 1 from 6:30 pm to 8:30 pm in 302 EE West. To receive full credit, your system must comply with the following specifications:

1. Use the signal assignments in Table 2.

Signal Designation	Signal Description	Microcontroller I/O designation	Pin Number
M_L	left motor drive	RB15	26
M_R	right motor drive	RB14	25
S_L	left sensor signal	RA0	2
S_R	right sensor signal	RA1	3
S_B	back sensor	RPI32	4

Table 1: The myDAQ Digital I/O assignments.

2. Connect the input switches and output LEDs as indicated in Figure 3. Note that pressing a given button sets the signal to a logic high state, while the corresponding logic level at the microcontroller peripheral I/O pin connector is at logic low state. For example, when the user presses the button S_L , the value of S_L becomes one while the corresponding logic level at pin 2 (RA0) is zero.

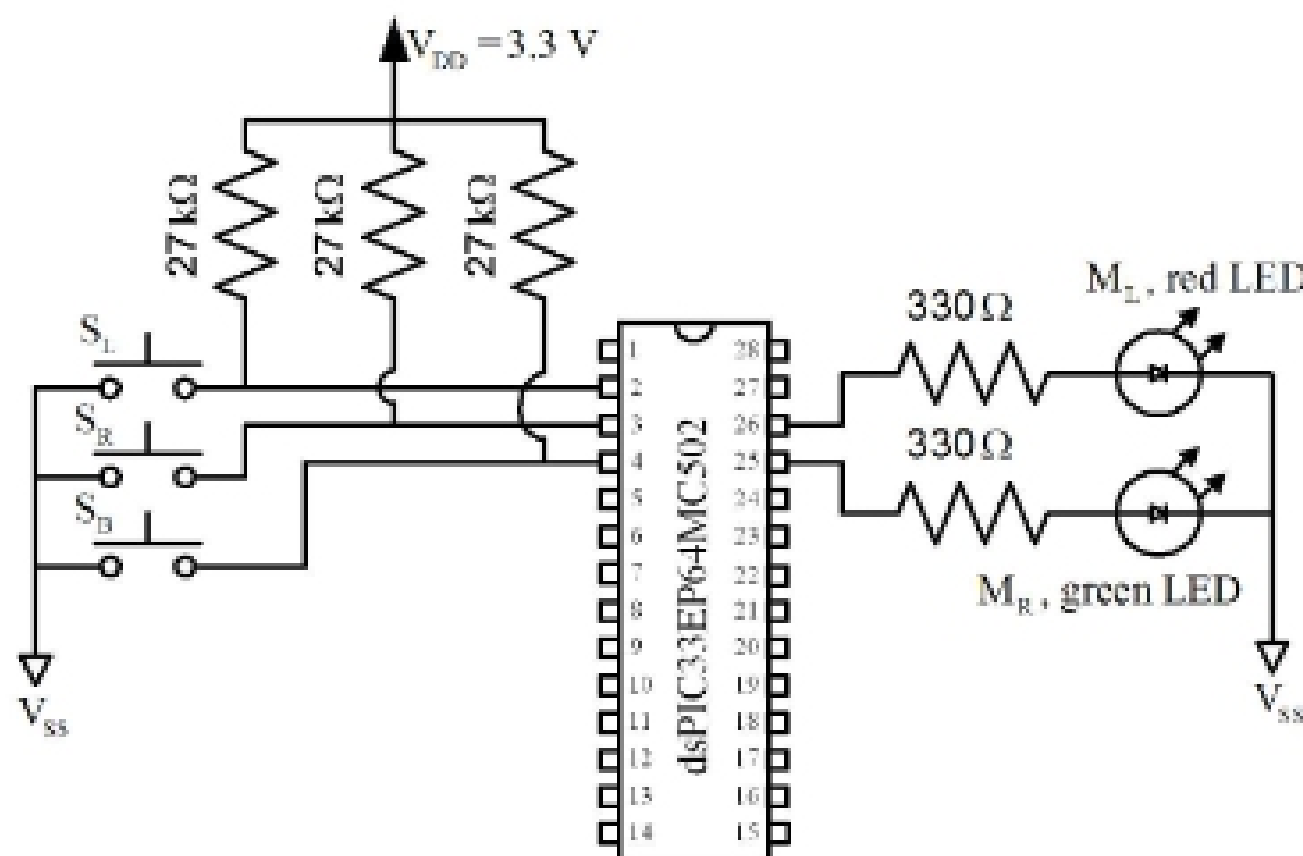

Figure 3: Microcontroller connections to input switches and output LEDs.

3. Implement the FSM in C using Exercise 3 in Laboratory #16 as a guide.
4. Realize the finite state machine using two nested switch statements within a while-loop as discussed in Laboratory #16. The inner switch statement acts on the values of the sensor inputs S_L and S_R . Simplify the code for the inner switch statement by using a single integer variable, called input, to represent S_L and S_R as shown in Table 2.

Input	Integer
$S_R S_L$	0
$S_R \bar{S}_L$	1
$\bar{S}_R S_L$	2
$\bar{S}_R \bar{S}_L$	3

Table 2: Representation of front sensor inputs using an integer.