

PROBLEM SET #8

Issued: Tuesday, March 31, 2009

Due: Tuesday, April 7, 2009, 8:00 p.m. in the EE 140 homework box in 240 Cory

1. This problem concerns the class B output stage shown in Figure PS8-1(a). The input signal is $v_{IN} = V_m \sin(2\pi f_{in} t)$.
 - (a) If the load is resistive $Z_L = R$ sketch timing diagrams of the output voltage $v_{OUT}(t)$, the load current $i_L(t)$, and collector currents $i_{C1}(t)$ and $i_{C2}(t)$.
 - (b) Repeat (a) if the load is capacitive $Z_L = \frac{1}{j\omega C}$.
 - (c) The output stage is connected in a feedback loop as shown in Figure PS8-1(b). Sketch timing diagrams of $v_{OUT}(t)$, $i_L(t)$, $i_{C1}(t)$, $i_{C2}(t)$, and $v_A(t)$ if $Z_L = R$. Assume amplifier A is ideal.
 - (d) Repeat (c) if $Z_L = \frac{1}{j\omega C}$.

Draw only one period in steady state. Clearly mark all important points in your diagrams.

$$V_m = 9V, f_{in} = 1kHz, C = 100 pF, R = 500\Omega, |V_{BE,on}| = 0.7V, V_{CC} = V_{EE} = 10V.$$

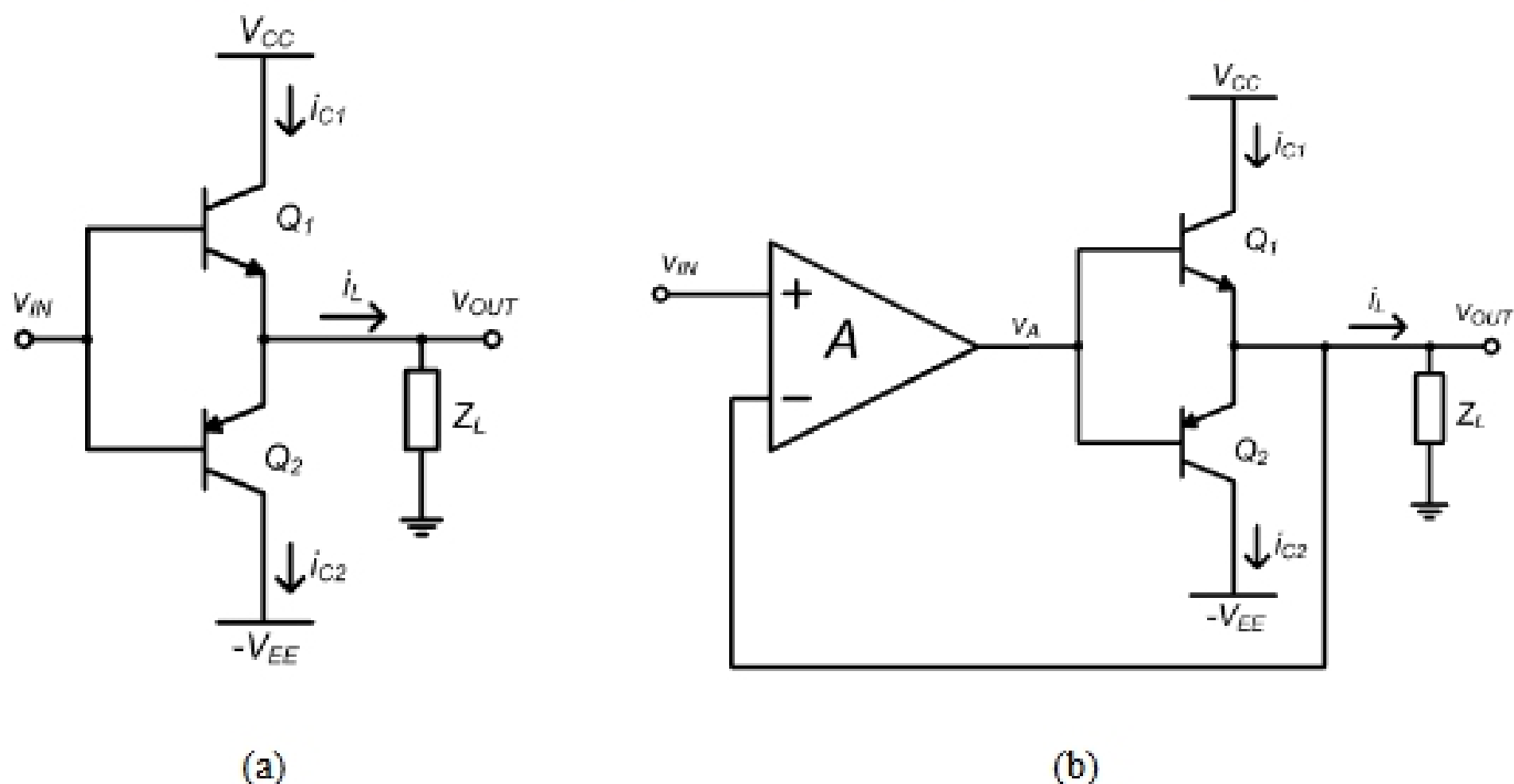

Figure PS8-1

2. The slew rate of the circuit in Fig. PS8-2 is to be increased by using two $10\text{ k}\Omega$ resistors placed at the emitters of Q_1 and Q_2 . If the same unity-gain frequency is to be achieved, calculate the new value of compensation capacitor required and the improvement in slew rate.

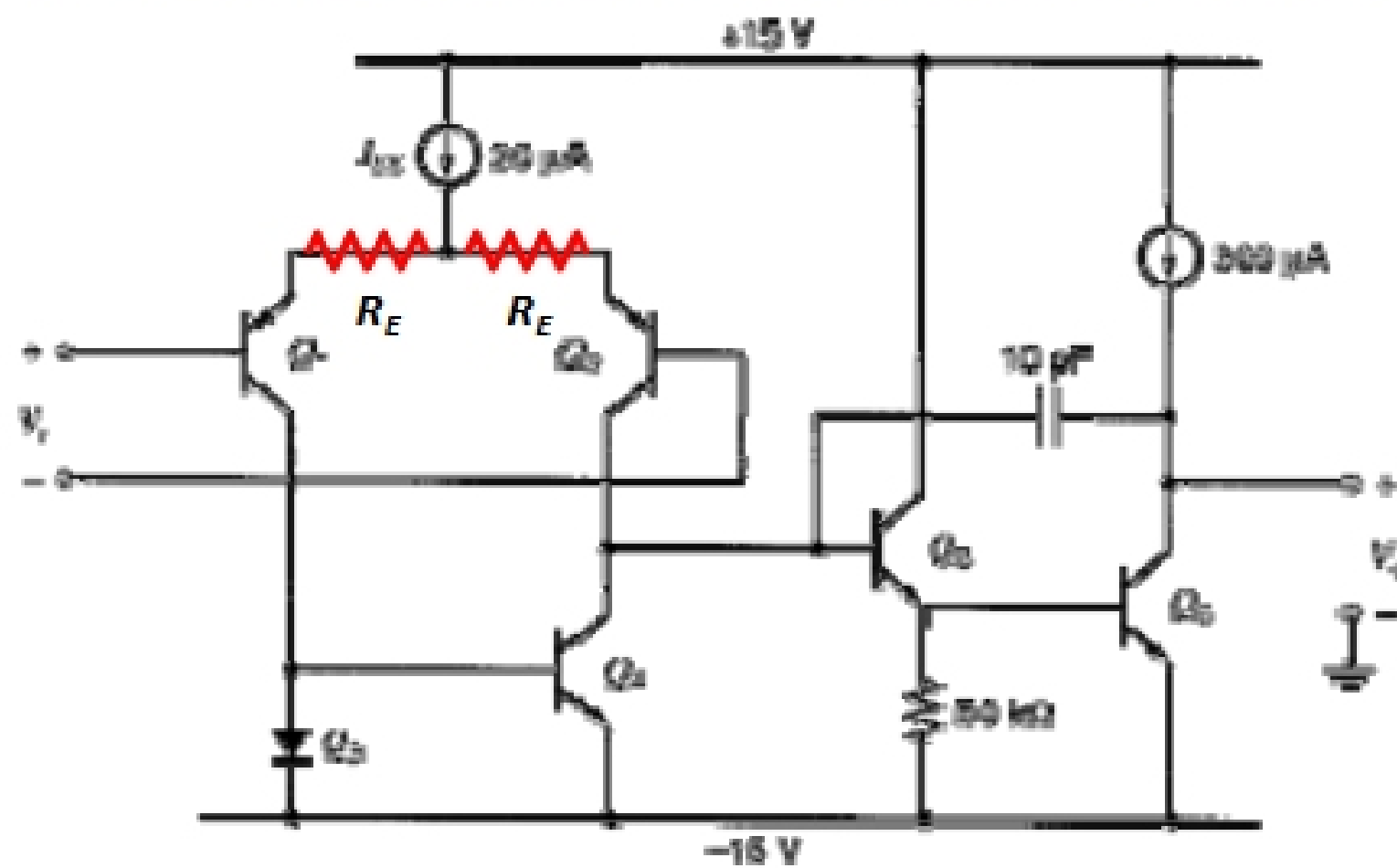

Figure PS8-1

3. Razavi, Chapter 9: Problem 9.19.
4. Razavi, Chapter 9: Problem 9.20.