

Circuit Problem (1)

→ The light bulbs in the circuit are identical. What happens when the switch is closed?

- ◆ (a) both bulbs go out
- ◆ (b) the intensity of both bulbs increases
- ◆ (c) the intensity of both bulbs decreases
- ◆ (d) A gets brighter and B gets dimmer
- ◆ (e) nothing changes

Before: Potential at (a) is 24V, but so is potential at (b) because equal resistance divides 48V in half. When the switch is closed, nothing will change since (a) and (b) are still at same potential.

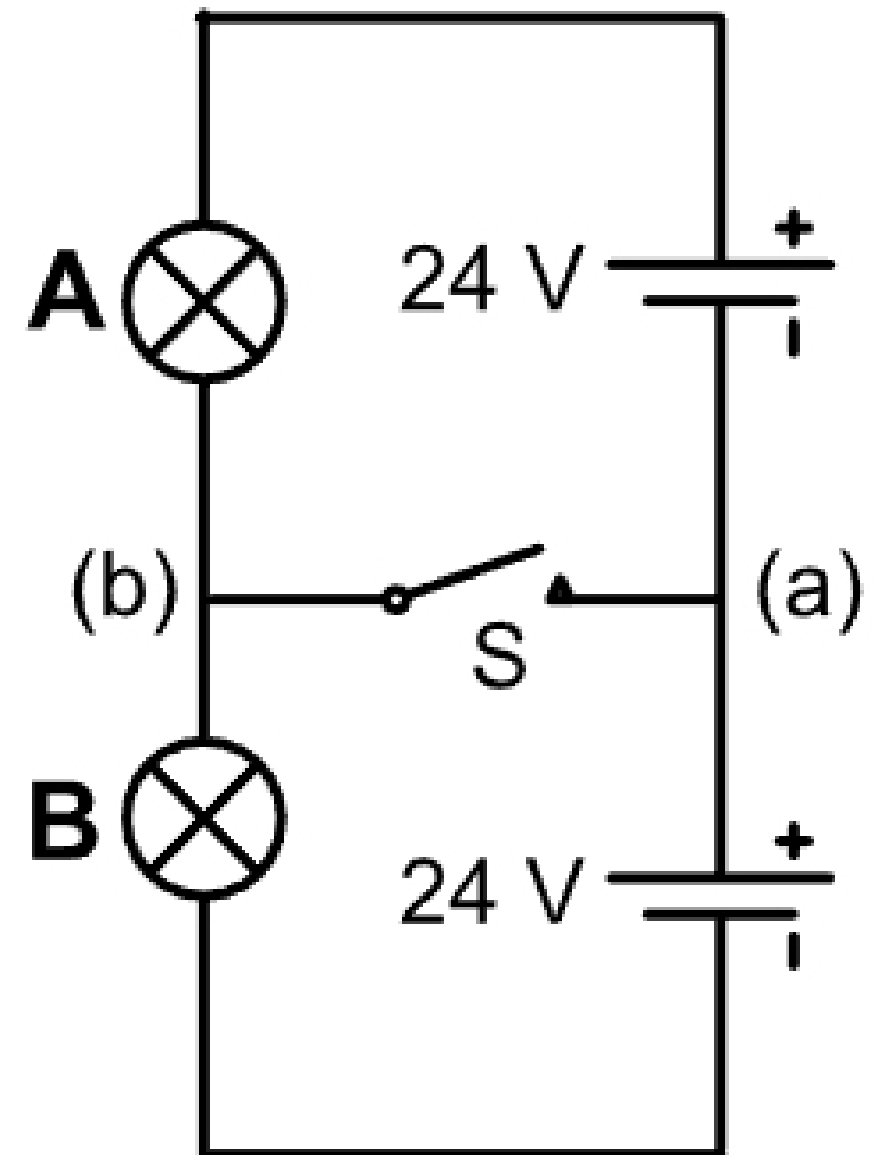

Circuit Problem (2)

→ Bulbs A and B are identical. What happens when the switch is closed?

- ◆ (a) nothing happens
- ◆ (b) A gets brighter, B dimmer
- ◆ (c) A gets dimmer, B brighter
- ◆ (d) Both A and B get brighter
- ◆ (e) Both A and B get dimmer

Before: Bulb A and bulb B both have 9V across them.

After: Bulb A has 12V across it and bulb B has 6V across it (these potentials are forced by the batteries).

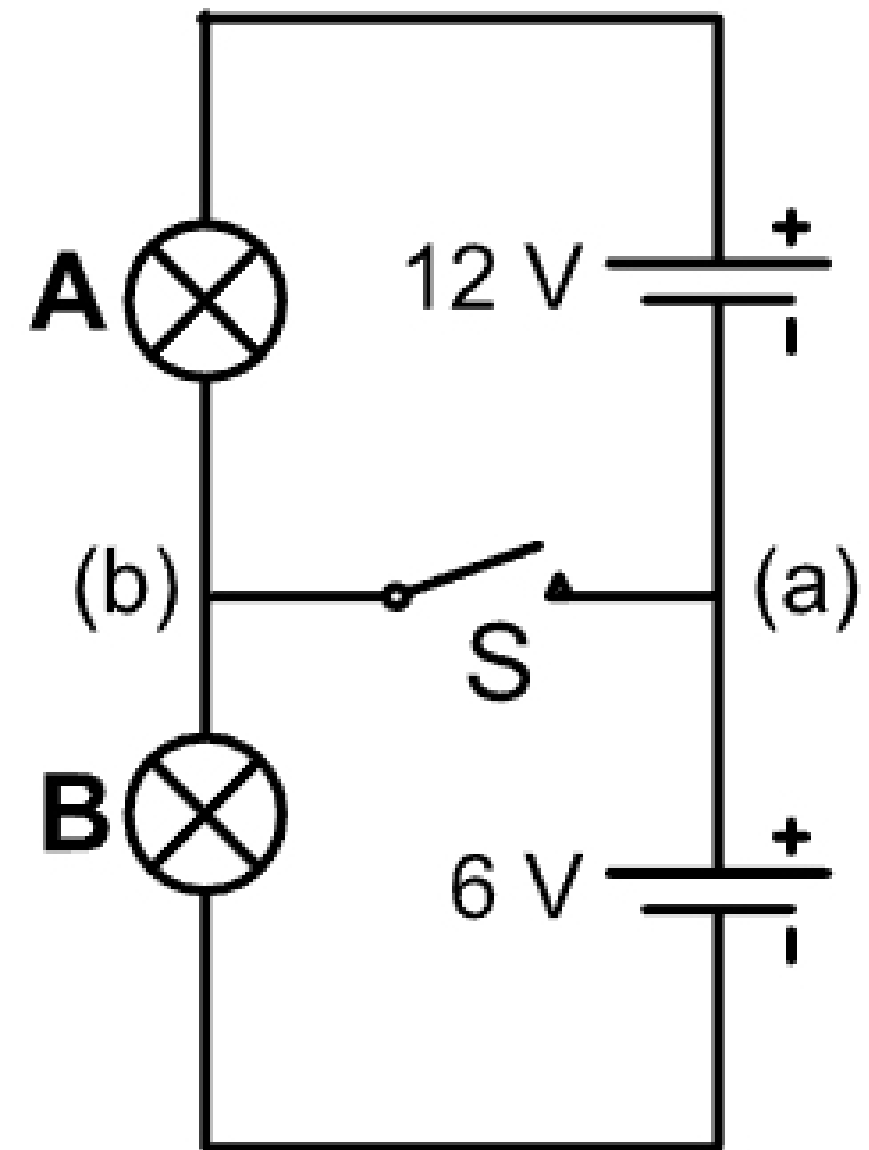

Calculate Currents

