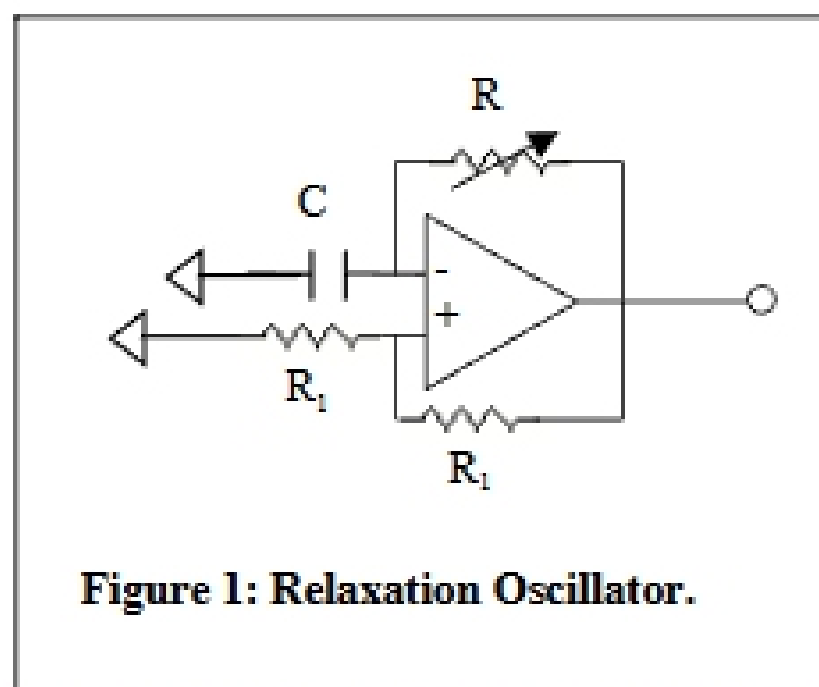
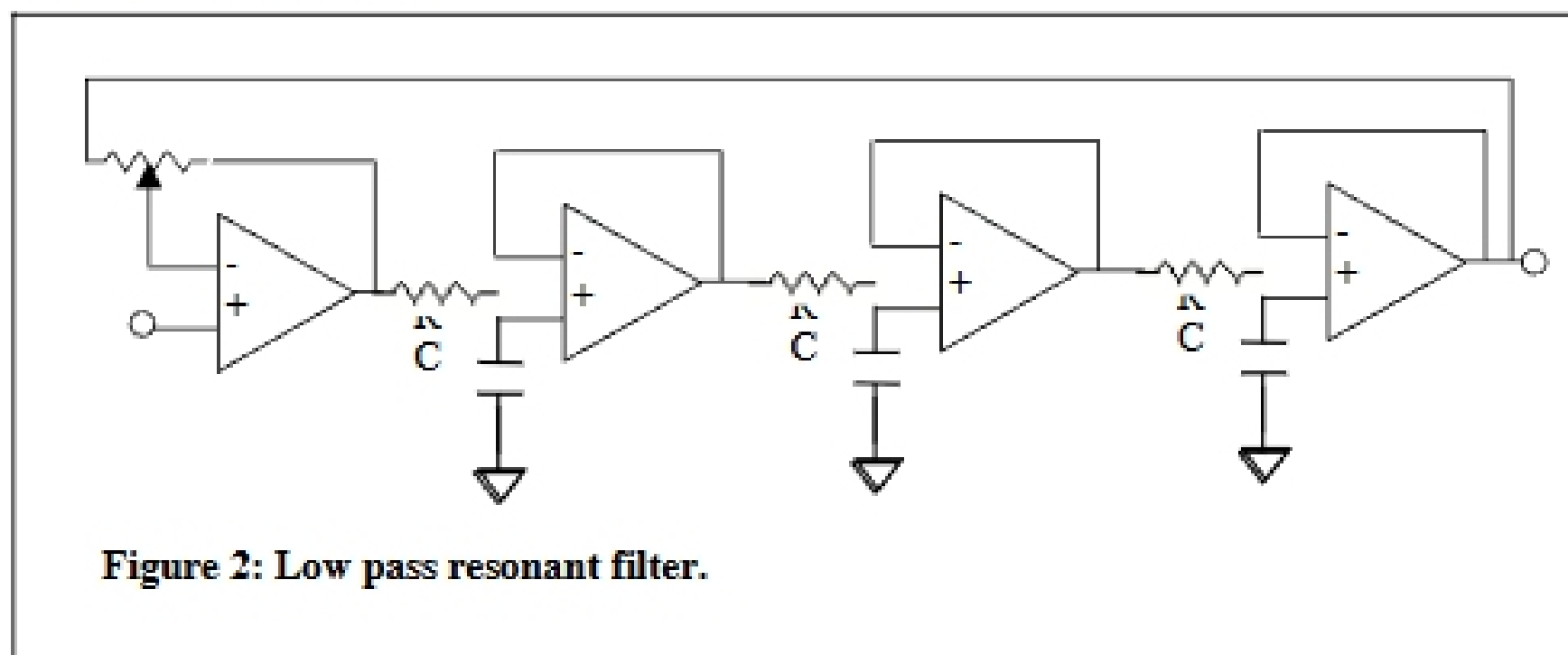

Op Amps II

Op-amp relaxation oscillator

Build the relaxation oscillator shown in Figure 1 above. The output should be a square wave with a frequency about $1/(2RC)$. Resistor R_1 can be any value between 1K and 1 M. Resistor R is one side of a potentiometer. Examine the voltages at (+) and (-) inputs and at the output and follow the action of the switching. It is useful to display v_+ and v_- simultaneously on the same scale to illustrate that the switching occurs at the crossover of v_+ and v_- . Note that the small triangular symbols indicate connections to ground.

Low-pass resonant filter

Show that the transfer function for the low pass resonant filter, shown in Figure 2, is given by:

$$H(\omega) = \frac{1}{1 - x + x(1 + j\omega\tau)^3}$$

where $\tau = RC$ and x is the ratio of R_1 to the total pot resistance $R_1 + R_2$. Here R_1 is the part of the pot resistance between the output and the inverting input of the first opamp

and R_2 is the part of the pot resistance between the inverting input and output of the first opamp.

[Hint: Begin by naming the output voltages of each op amp, from left to right, as v_1 through v_4 . Then use the infinite gain assumption to show that:

$$\frac{(v_4 - v_{in})}{R_1} = \frac{(v_{in} - v_1)}{R_2}$$

Next, use what you know about RC filters to find v_4 in terms of v_1 .]

When you understand the equation for the transfer function, build the circuit. It is convenient to use a TL084 with four op amps in a package.

Choose RC so that the resonant frequency is 2 to 5 kHz. Tune the pot until the circuit nearly oscillates. See how close you can get. Notice how oscillations grow and die exponentially. Find the resonant frequency by feeding in a sine signal from a function generator. (You may need to decrease the input voltage considerably to avoid saturating the filter near resonance.) Check the high frequency roll off. It should be proportional to $1/\omega^3$. Estimate the gain at resonance. Observe how the phase shift changes at resonance. Observe that the phase shift is not zero at the frequency where the gain is maximum. Make a Bode plot of the transfer function. (Spend your time wisely here by starting with a survey to find the frequencies where important features occur. Important features include resonance, high-frequency roll off and low-frequency constant region.)