

COS426

Non-photorealistic Rendering

Lee Markosian

Q: What is computer graphics about?

A: Providing tools to help human designers produce images that communicate visual information for some purpose.

Whether to use photorealism depends on the purpose of the image:

- Documentation
- Illustration
- Story-telling
- Expression

Qualities of hand-drawn images

- Many details left out
- Some details emphasized
- Stylization / abstraction
 - used to evoke complex things
- Recognizable individual style

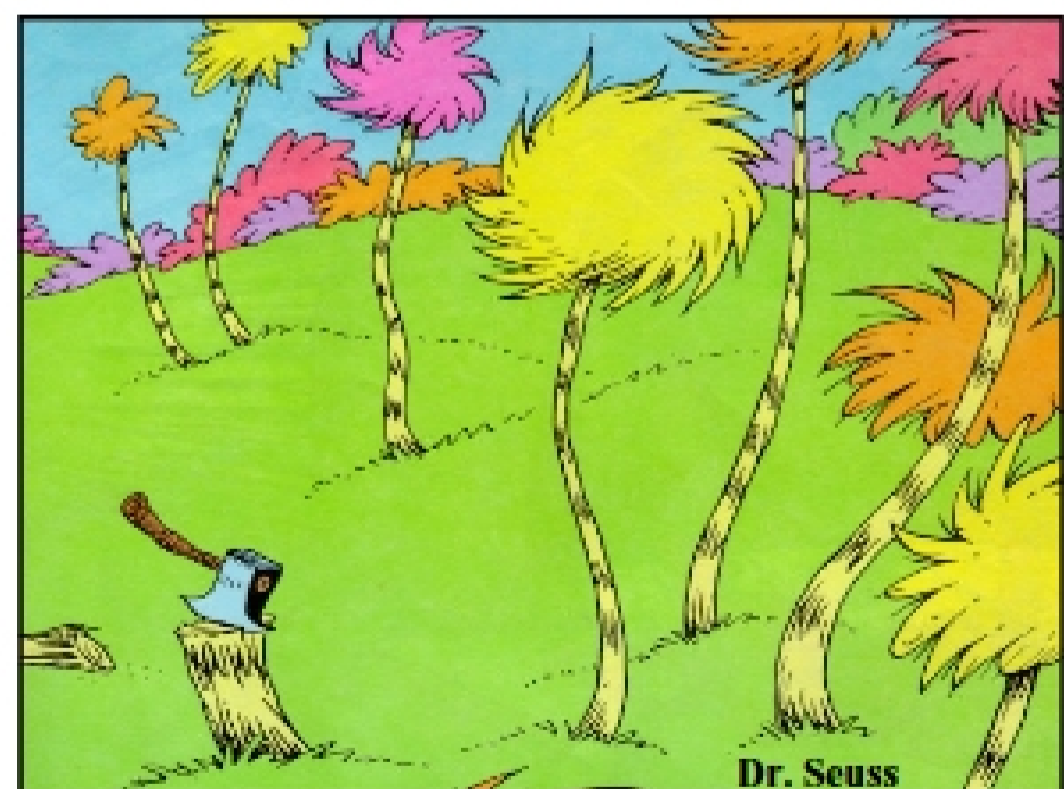



Monet

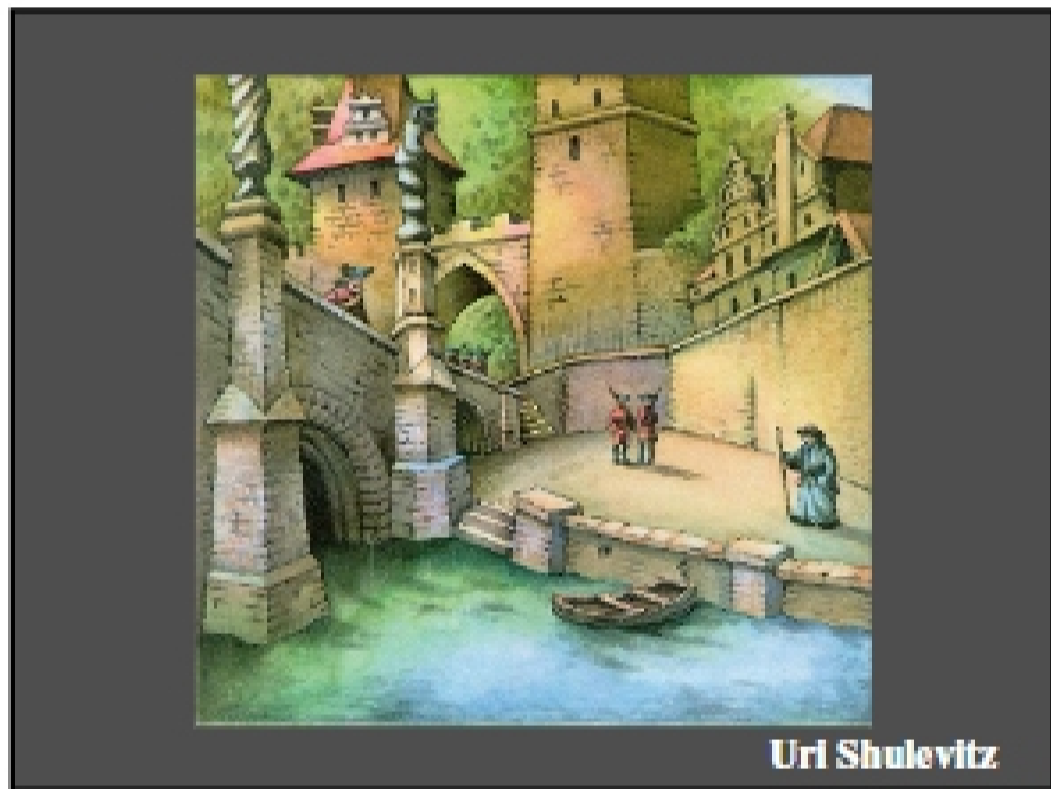

Uri Shulevitz

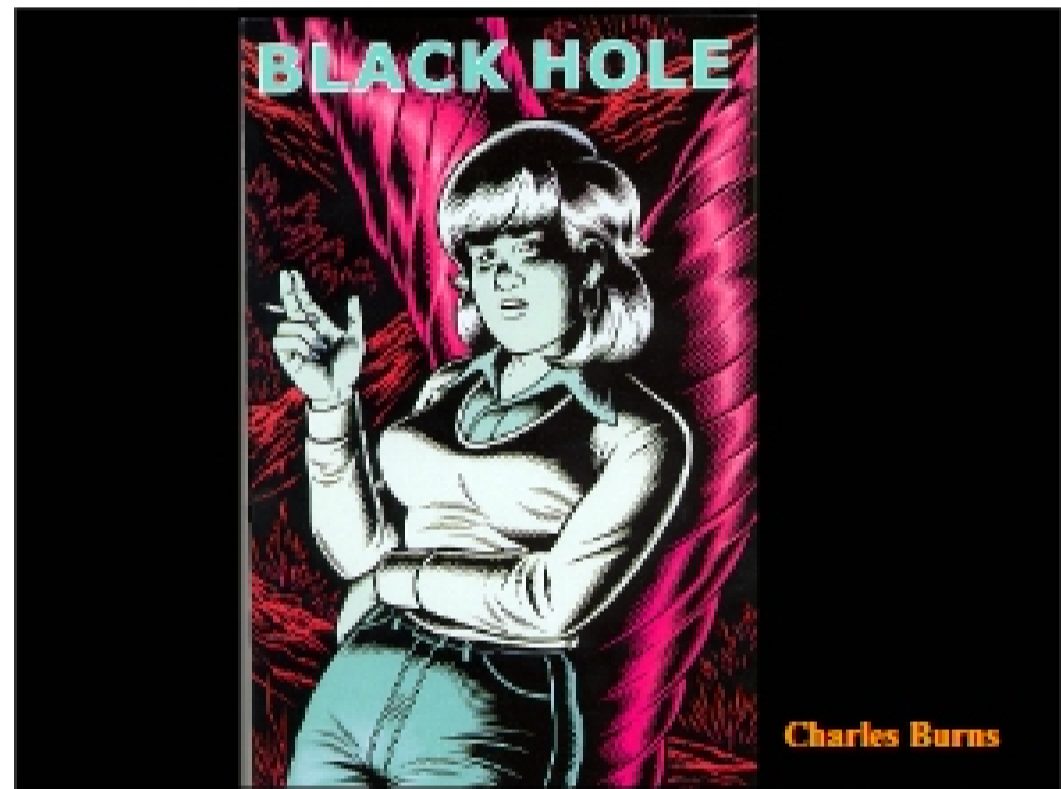

Charles Burns

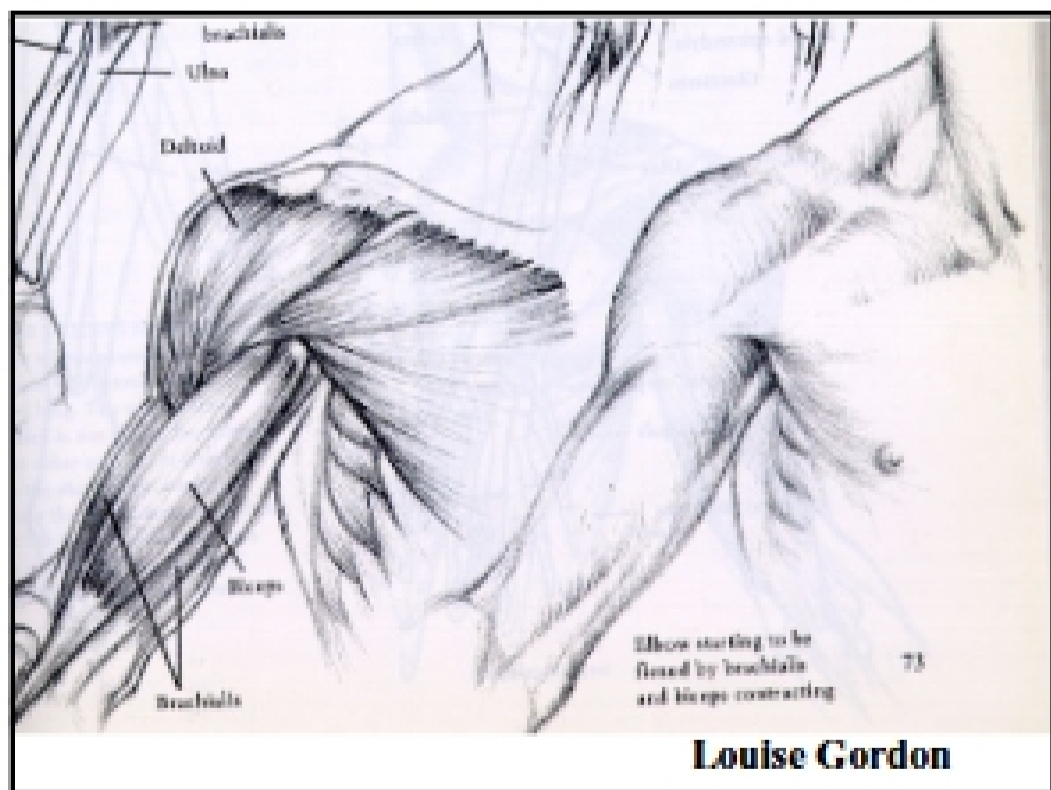

Louise Gordon

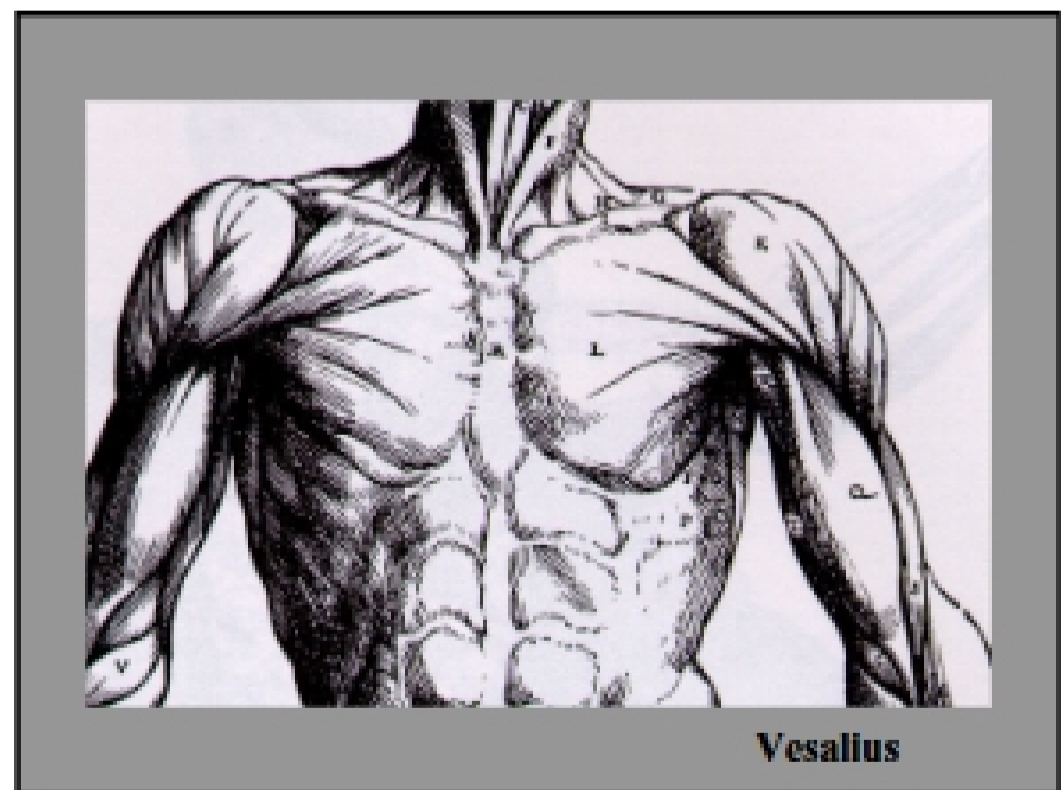

Vesalius

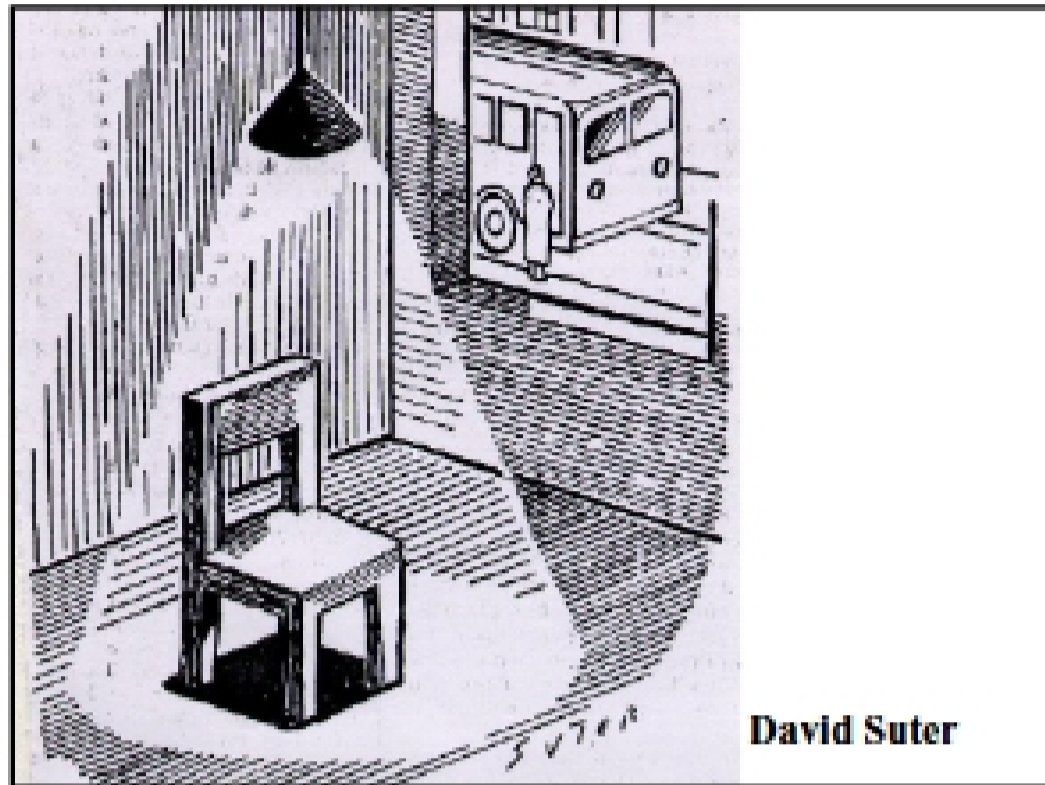

David Suter

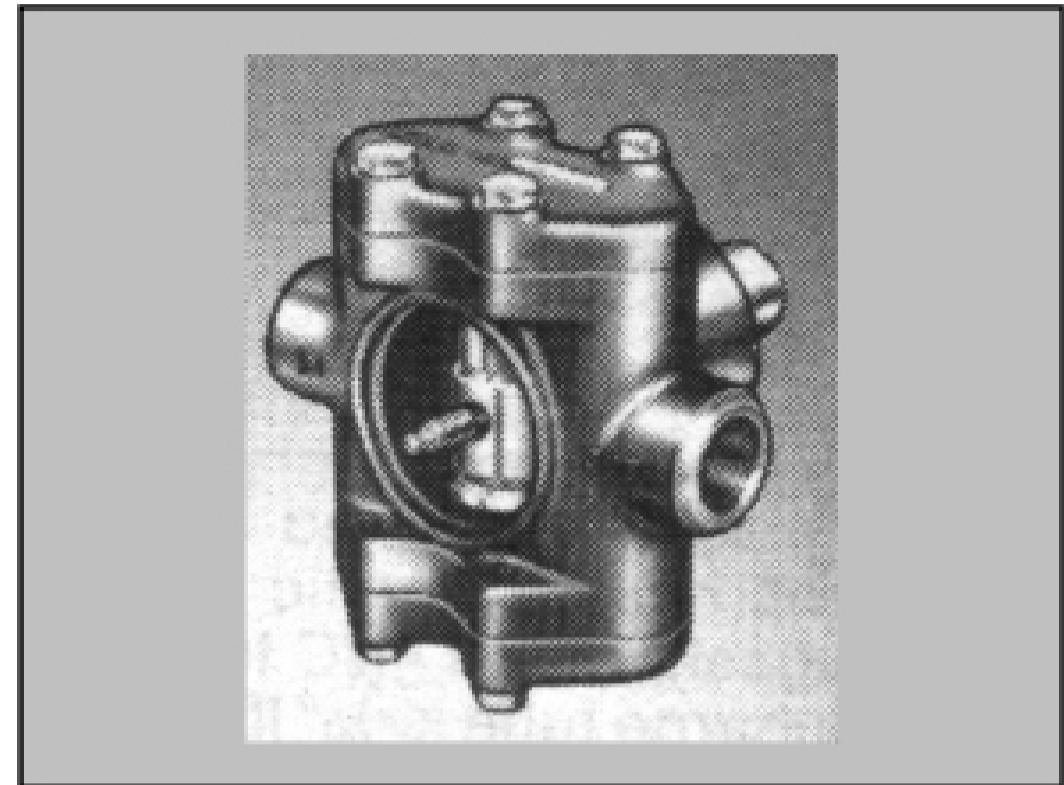

Outline

- Technical illustration
- Pen & Ink
- Painterly rendering for animation
- Cartoonish rendering

Technical illustration

- Saito and Takahashi, Siggraph 90
- Purpose: render 3D models in styles that are more “comprehensible”
- Method:
 - Render various intermediate images
 - Do image-processing operations on them
 - Combine the results

