

Recitation 22: CS Amplifier Frequency Response

Yesterday, we discussed the frequency response of a CE Amplifier, using the following methods.

- Full analysis (using model Analysis to derive $\frac{V_{out}}{V_s}$)
- Miller approximation
- Open circuit time constant technique

Today we will look at the frequency response of CS Amplifier using 2-3.

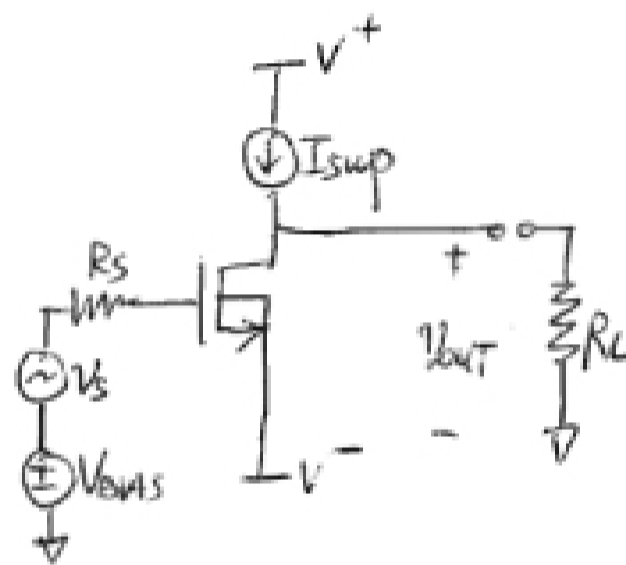

Small signal equivalent circuit model

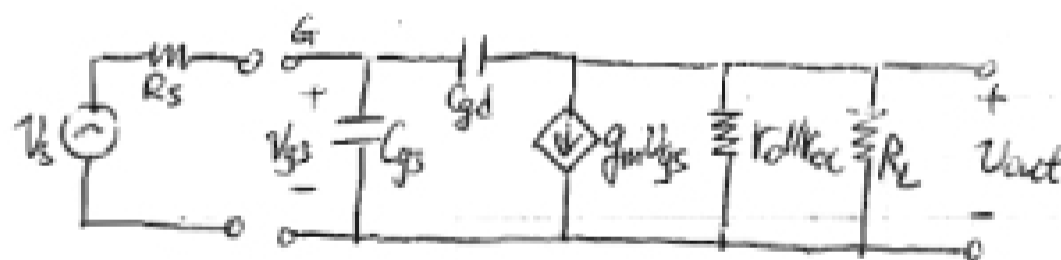

Low frequency voltage gain (ignoring the two capacitors)

$$A_{v,LF} = \frac{V_{out}}{V_s} = -g_m R_{out} \text{ where } R_{out} = r_o \parallel r_{oc} \parallel R_L$$

$$(\because V_{gs} = V_s, V_{out} = -g_m R'_{out} V_{gs} \implies \frac{V_{out}}{V_s} = -g_m R'_{out})$$

Miller Approximation

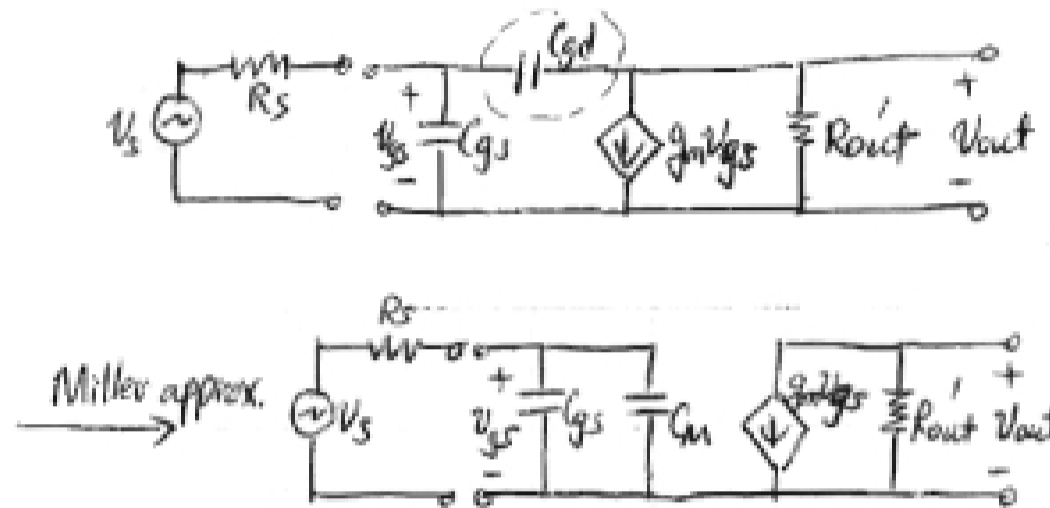

$$C_M = C_{gd}(1 - A_{vC_{gd}}) = C_{gd}(1 + g_m R'_{out})$$

C_{gd} is in the position between input and output

$$V_{out} = -g_m V_{gs} \cdot R'_{out}$$

$$V_{gs} = \frac{Z_c}{Z_c + R_s} \cdot V_s, \text{ where } Z_c = \text{impedance of 2 capacitors } (C_{gs} \text{ \& } C_M) \text{ in parallel}$$

$$Z_c = \frac{1}{j\omega(C_{gs} + C_M)}$$

$$V_{gs} = V_s \frac{1/j\omega(C_{gs} + C_M)}{1/j\omega(C_{gs} + C_M) + R_s} = \frac{1}{1 + R_s(j\omega(C_{gs} + C_M))} \cdot V_s$$

$$\therefore \frac{V_{out}}{V_s} = -\frac{g_m R'_{out} \cdot V_{gs}}{V_s} = -g_m R'_{out} \frac{1}{1 + j\omega R_s(C_{gs} + C_M)}$$

$$\omega_{3dB} = \frac{1}{R_s(C_{gs} + C_M)} = \frac{1}{R_s(C_{gs} + C_{gd}(1 + g_m R'_{out}))}$$

To compare with CE Amplifier,

$$\omega_{3dB} = \frac{1}{R'_{in}(C_\pi + C_\mu(1 + g_m R'_{out}))} \quad R'_{in} = R_s || r_\pi$$

Open Circuit Time Constant Analysis

Assumptions

1. No zeros (or zeros can be ignored)
2. One dominant pole ($\frac{1}{\tau_1} \ll \frac{1}{\tau_2}, \frac{1}{\tau_3} \dots$)

Procedures

1. Open circuit all capacitors

2. Turn off all independent sources, find Thevenin resistance for each capacitor

3. Sum up the $R_{TH} \cdot C_i \Rightarrow b_1 = \sum_i C_i R_{TH_i}$, $\omega_{3dB} \simeq \frac{1}{b_1}$

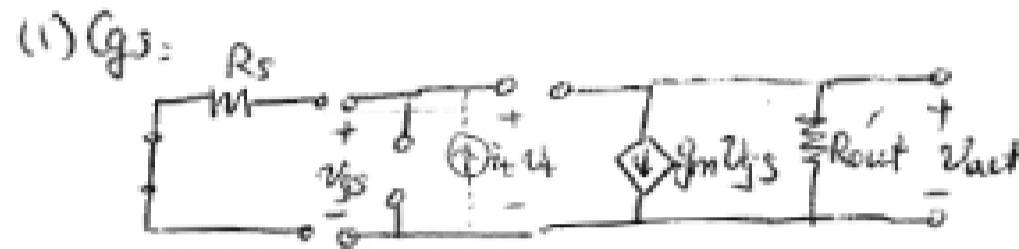

$$R_{TH1} = R_s$$

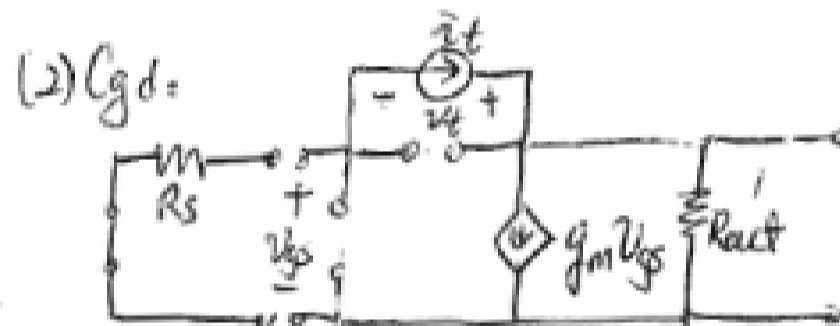

$$i_t = -\frac{V_{gs}}{R_s}, \quad i_t = g_m V_{gs} + \frac{V_t + V_{gs}}{R'_{out}}$$

$$\Rightarrow i_t = g_m(-R_s \cdot i_t) + \frac{V_t + (-R_s \cdot i_t)}{R'_{out}}$$

$$i_t \cdot R'_{out} = (-g_m R'_{out} \cdot R_s - R_s) \cdot i_t + V_t$$

$$V_t = i_t (R'_{out} + R_s(1 + g_m R'_{out}))$$

$$R_{TH2} = \frac{V_t}{i_t} = R'_{out} + R_s(1 + g_m R'_{out})$$

$$\Rightarrow b_1 = C_{gs} \cdot R_{TH1} + C_{gd} \cdot R_{TH2}$$

$$= C_{gs} \cdot R_s + C_{gd} \cdot (R'_{out} + R_s(1 + g_m R'_{out}))$$

$$\omega_{3dB} \simeq \frac{1}{b_1} = \frac{1}{R_s(C_{gs} + C_{gd}(1 + g_m R'_{out})) + R'_{out} \cdot C_{gd}}$$

This is actually also the result if we do full analysis