

PmodLS1™ Infrared Light Detector Module Reference Manual

Revision: August 14, 2007

Note: This document applies to REV A of the board.



215 E Main Suite D | Pullman, WA 99163
(509) 334 6306 Voice and Fax

Overview

The PmodLS1 module is an interface module for connecting optical sensors to digital inputs on a Digilent system board. When used with reflective infrared light detector sensors (available from Digilent), the PmodLS1 is ideally suited for use in line-sensing robots. It is also well-suited for use as a general-purpose interface for either reflective or transmissive photo detectors.

The module can be used with Digilent microcontroller boards or Digilent FPGA boards.

Functional Description

The PmodLS1 is designed to be used with sensors containing an infrared LED and an infrared-sensitive photo-transistor. The module supports up to four sensors connected at the S1, S2, S3, and S4 headers. Digilent has reflective-type sensors available for use with the PmodLS1. When using Digilent's sensors, refer to the print on the board for the orientation of the wire. If third-party sensors are used, refer to the connection diagram in figure 2 or the board schematic available at www.digilentinc.com for the proper connection of the LED and photo-transistor.

The PmodLS1 uses the VCC pin (pin 6) of the Pmod connector J1 to power the infrared LEDs. The module uses analog comparators to determine when the infrared detectors have sensed more infrared light than the threshold limit. The sensitivity of the sensors can be adjusted by adjusting the onboard potentiometer.

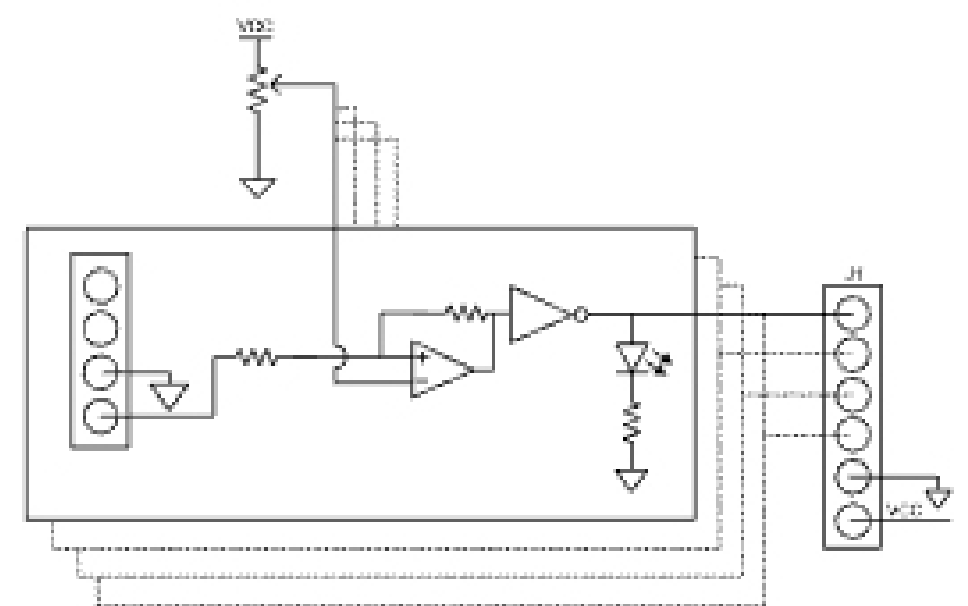
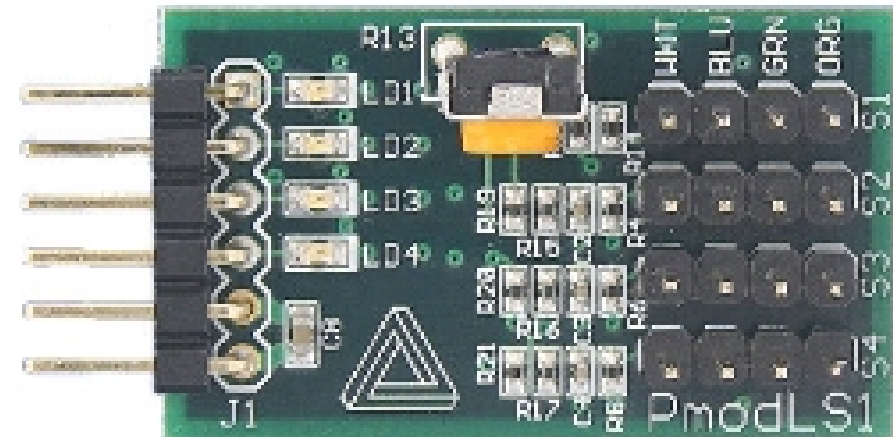

Figure 1 PmodLS1 Circuit Diagram

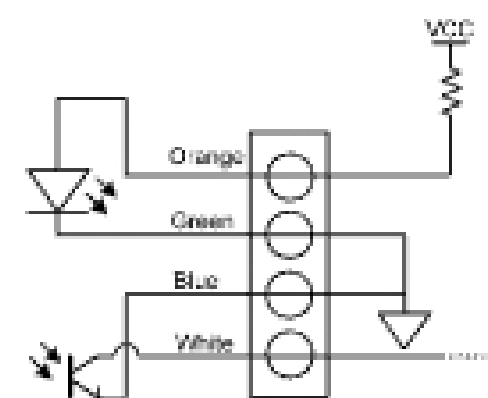

Figure 2 Sensor Connection Diagram

The PmodLS1 is equipped with onboard LEDs that are used as visual indicators of the status of the four available sensors inputs. When a sensor is picking up more infrared light than the threshold limit, the corresponding LED will be illuminated and the corresponding output pin on J1 will output a logic 1. If the sensor is picking up less light than the threshold limit, the corresponding LED will be off and the corresponding output pin on J1 will output a logic 0.