

Name (print): _____

Section _____ Table _____ Group _____

Honor Code: I have neither given nor received unauthorized aid
on this test

Signature: _____

ME 201 Sample Test #3

Fall 2007

NOTES:

- Sign and provide identifying info on every sheet.*
- Use proper vector notation in all cases where vectors are used.*
- In cases involving Newton's Laws, you are **REQUIRED** to draw complete and correct FBDs and when the problem is dynamics, you must also draw complete and correct KDs. Then use these to develop your governing equations.*
- If you use you calculator to perform any calculus that might involve trig or similar functions, set your calculator to the radian mode first.*
- In all cases, remember to show results with magnitude, direction, units and put your answer in a box.*

Sample Test 3a Many more problems are given here than you should expect, however these are a representative samples of the material we covered in this section of the course.

3. (a) (10 pts) The pin at B is attached to member ABCD and an slide along the slot in member BE. Neglecting all friction, determine the magnitude of the couple M needed to hold the system in equilibrium.
- (b) (5 pts) If the coefficient of static friction is 0.25 between the pin and the slot, find the smallest value of the couple M that will keep the system in equilibrium.

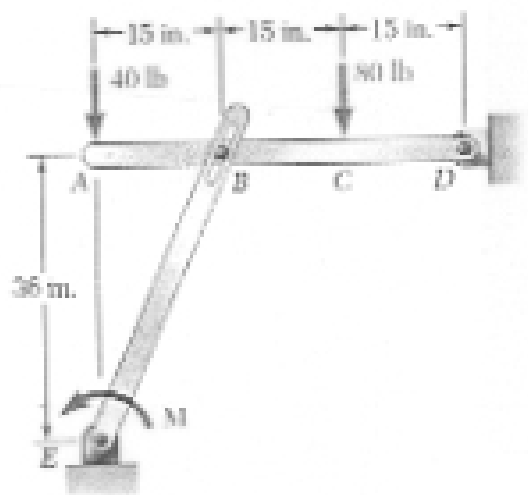

EM 201 Sample Test 3

- ① Write the shear & moment equations (using our standard sign convention for beams) for the beam. Reactions are given. All units are kips & ft.

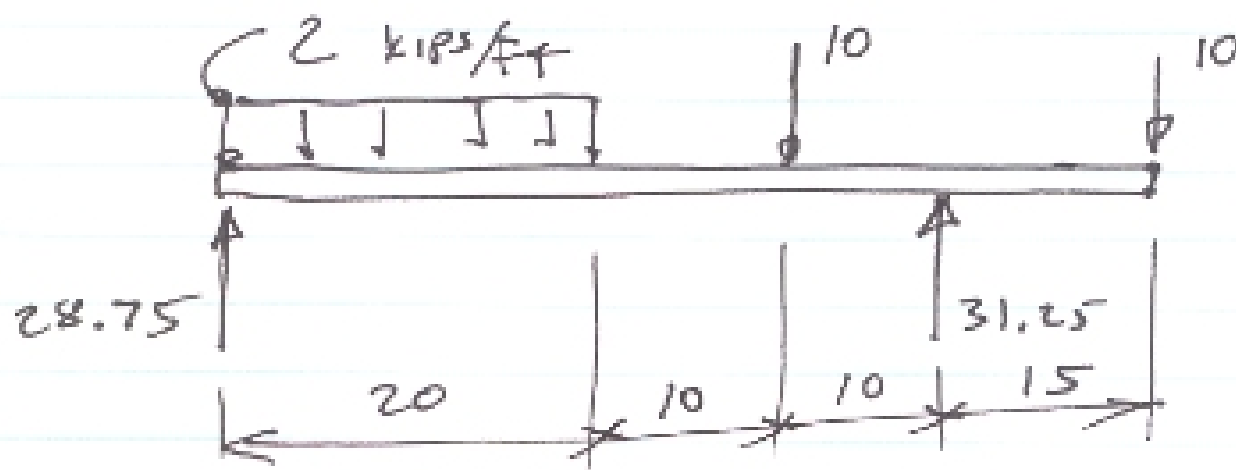

Now plot the diagrams using standard shear and bending moment convention for beams.