

UNIVERSITY OF CALIFORNIA AT BERKELEY
 College of Engineering
 Department of Electrical Engineering and Computer Science

R. W. Brodersen
 Sohrab Emami
 David Sobel

Design Problem 2
 (Due 11/10/04)

EECS 140
 Fall 2004

You can work in groups of two, or alone. If you work in groups of two, submit only one project report per group. There will be no extra credit for working alone. Information on what to include in the report and how to submit your circuit will be available later.

Design Objective

The objective of this project is to design an operational amplifier (Figure 1) with a differential input and a single-ended output. It must meet the following specifications:

Specification	Condition	Notes
L_{min}	0.13 μ m	L must be integer multiple of 0.01 μ m
W_{min}	0.15 μ m	W must be integer multiple of 0.01 μ m
V_{DD-min}	1.2V	Supply voltage, V_{DD} , varies from V_{DD-min} to V_{DD-max} .
V_{DD-max}	1.4V	
V_{SS}	0V	
R_L	1k Ω	Don't include the load in your schematic. It is automatically included in the testbenches
R_S	500 Ω	Don't include the source resistance in your schematic. It is included in the testbenches
$A_{DM0} (=V_{out}/V_{id})$	≥ 1000	Low frequency small-signal differential-mode voltage gain
$A_{CM0} (=V_{out}/V_{ic})$	≤ 0.1	Low frequency small-signal common-mode voltage gain
$V_{ICM,max} - V_{ICM,min}$	$\geq 0.3V$	A_{DM0} and A_{CM0} specs must be met over this common-mode swing for both V_{DD-min} and V_{DD-max} @ $V_{OUT}=0.6V$
$V_{out,pp}$	$\geq 0.6V$	A_{DM0} spec must be met over this output swing for both V_{DD-min} and V_{DD-max} @ $V_{ICM,Q}$. (i.e. V_{OUT} must swing from 300mV to 900mV while maintaining A_{DM0} spec.)
Maximum supply current	1mA	Maximum supply current over the entire range of V_{out} and V_{DD} .
3dB-bandwidth of $A_{DM}(f) (=V_{out}(f)/V_{id}(f))$	Maximize	At $V_{out}=0.6V$, $V_{DD}=1.2V$, and $V_{ICM}=V_{ICM,Q}$. Also $ A_{CM}(f) $ must remain less than 0.1 over this bandwidth.

And the design goal is to **maximize the 3dB-bandwidth** of the differential to single-ended voltage gain of the amplifier.

The available circuit components are NMOS transistors, PMOS transistors, and resistors. (Ideal internal sources can not be used to generate bias currents or voltages.)

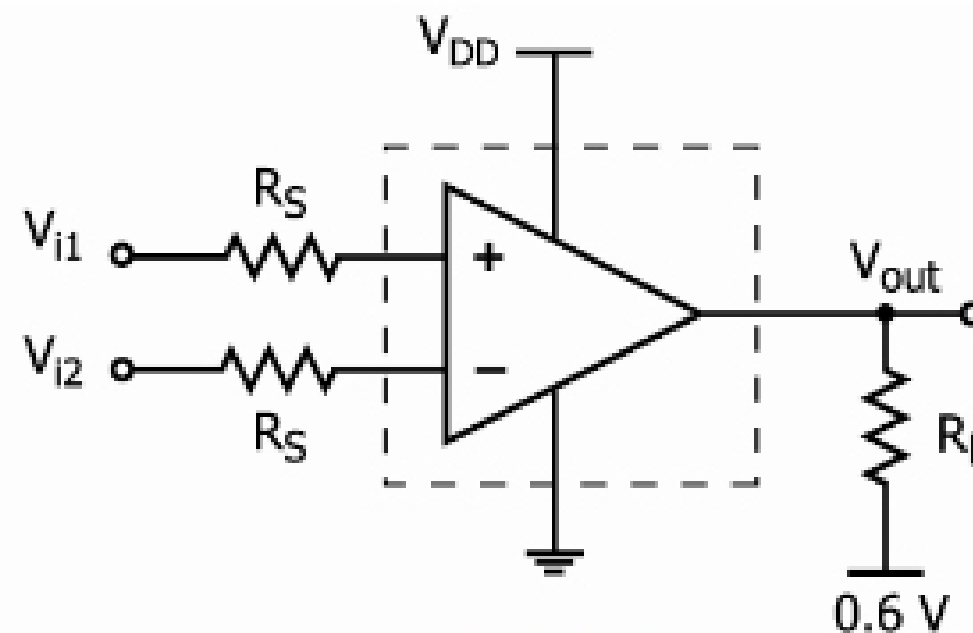

Figure 1

Device Models

http://bwrc.eecs.berkeley.edu/classes/ee140/dp/model_ee140.sp

The device models are encapsulated in a sub-circuit; use:

```
x1 d g s b nmos w=10u l=0.13u
x2 d g s b pmos w=10u l=0.13u
```

to instantiate an NMOS and a PMOS transistor respectively (you have to use the prefix 'x' instead of 'm'). The reason for using a subcircuit is to allow λ to decrease with increasing transistor length. The output resistance parameter λ will stay the same as before for minimum length transistors ($L_{min}=0.13\mu\text{m}$), but will decrease with increasing L (drawn L , not effective L). Since the output resistance is proportional to $1/\lambda$, the output resistance increases with increasing L .

Spice testbenches

Test benches will be provided for you to run a set of simulation tests on your circuit. Ultimately, your final circuit performance will be evaluated by these testbenches. More information on the testbenches (and the testbenches themselves) will be released in another document on the website.

Please note that the testbench files will include all your input sources (power, signal) as well as your source and output resistances. Therefore, you do NOT need to include these devices in your own netlist.

What to include in your report

See handout on webpage

Grading

100 points total:

25 points for conciseness and clearness of the report

40 points for meeting the specifications

25 points for how well the 3-dB bandwidth is maximized.

10 points for originality of the design.