

Name: Solutions

ID#: _____

DO NOT TURN THIS PAGE UNTIL YOU ARE TOLD TO DO SO

Problem	Weight	Score
1	25	
2	25	
3	25	
4	25	
Total	100	

This test consists of four problems. Answer each problem on the exam itself; if you use additional paper, repeat the identifying information above, and staple it to the rest of your exam when you hand it in. The quality of your analysis and evaluation is as important as your answers. Your reasoning must be precise and clear; your complete English sentences should convey what you are doing.

Problem 1: (25 points)

The closed-loop system in Figure 1 contains the plant

$$G_p(s) = \frac{s^2 - 2s + 2}{s(s+1)}$$

and proportional controller

$$G_c(s) = K_o.$$

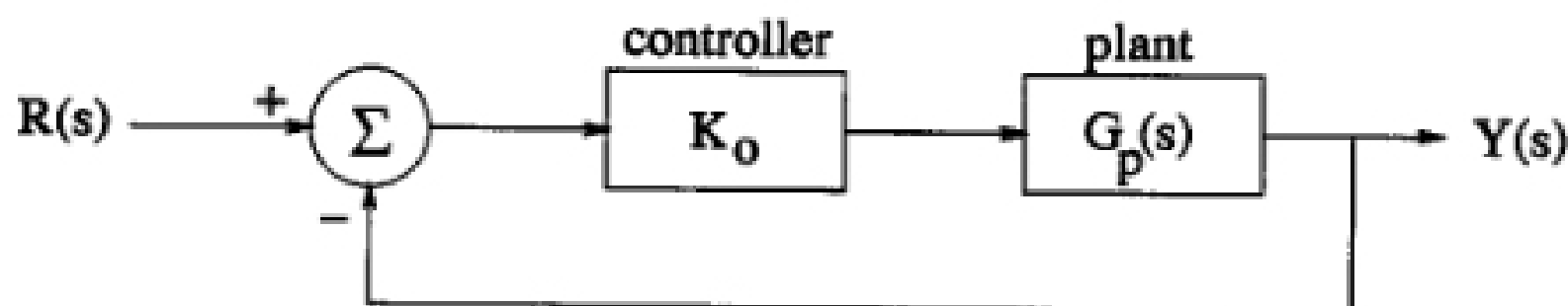

Figure 1: Closed-loop system with cascade compensation.

1. (4 points) Express the characteristic equation of the closed-loop system in a form suitable for constructing the root locus of the closed-loop system as the proportional gain K_o is varied from zero to infinity.
2. (4 points) Calculate the location of the break away point.
3. (4 points) Determine the value of the control gain K_o for which the closed-loop poles cross the $j\omega$ axis. Specify the location of the crossing point on the imaginary axis.
4. (4 points) Determine the angles of arrival at the complex zeros.
5. (4 points) Sketch the complete root locus using the graph in Figure 2. Appropriately label the break away point, $j\omega$ axis crossings, and angles of arrival. Use arrows to indicate the direction of travel along the loci as K_o increases towards infinity.

1.
$$1 + K_o \frac{s^2 - 2s + 2}{s(s+1)} = 0$$

2.
$$\frac{d}{ds} \left(- \frac{s^2 + s}{s^2 - 2s + 2} \right) = \frac{-(2s+1)(s^2 - 2s + 2) + (s^2 + s)(2s - 2)}{(s^2 - 2s + 2)^2} = 0$$

$$3s^2 - 4s - 2 = 0 \Rightarrow s^2 - \frac{4}{3}s - \frac{2}{3} = 0$$

$$s_{1,2} = +\frac{4}{6} \pm \sqrt{\frac{16}{36} + \frac{2}{3}} = +\frac{4}{6} \pm \sqrt{\frac{40}{36}} = \frac{4}{6} \pm \frac{2}{6}\sqrt{10}$$

The breakaway point must lie on the real axis between the poles at -1 and 0. And so we need to use the negative root.

The breakaway point is $\frac{2}{3} - \frac{1}{3}\sqrt{10} = -0.387$

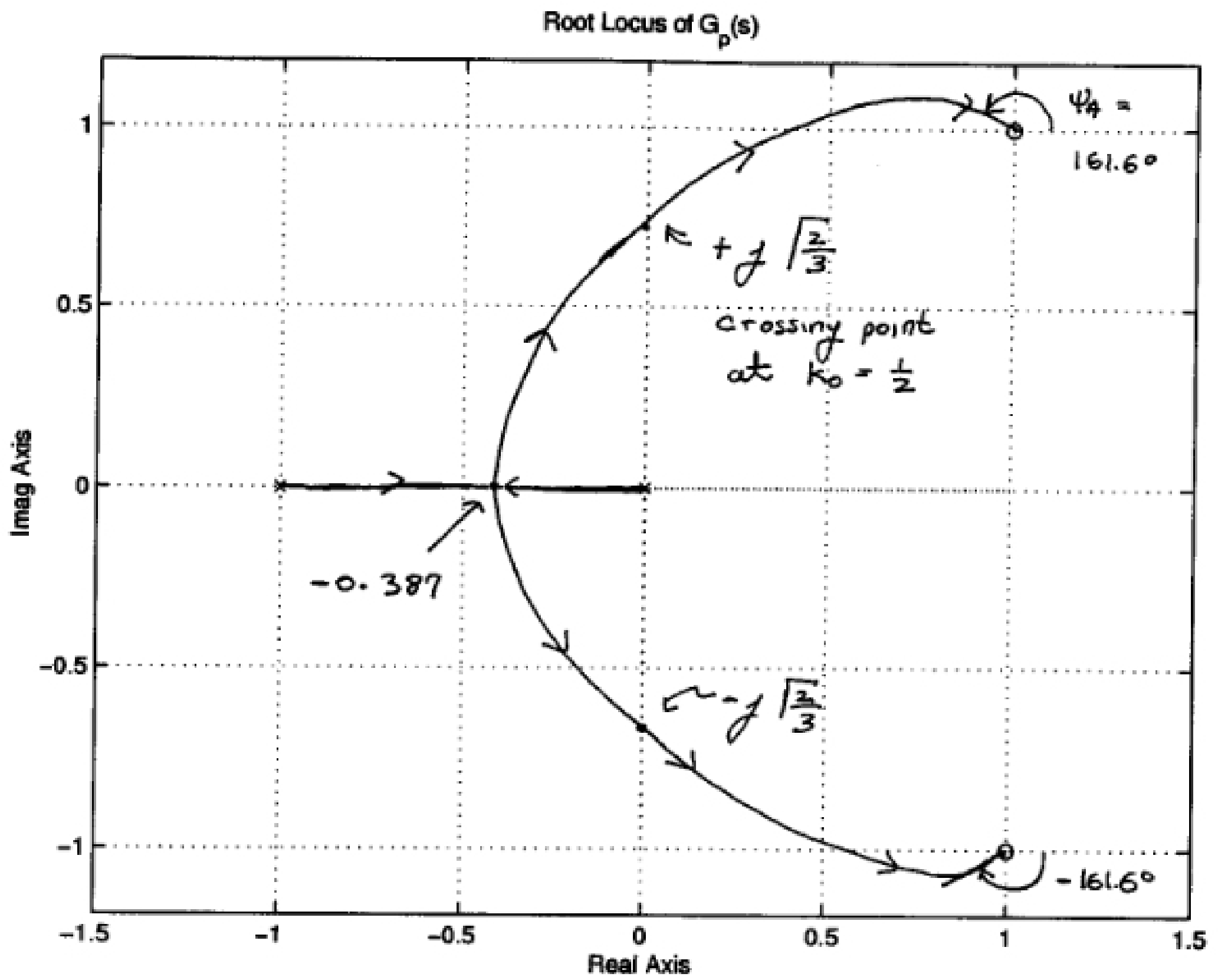

Figure 2: Root locus of the closed-loop system as the proportional gain K_0 is varied from zero towards infinity.