

1. (20 pts) The member OBC and pulley at C together have a mass of 500 kg, with a combined center of mass (center of gravity) at G . The size of the pulley is negligible compared to the other dimensions. The collar at A can provide support only in the horizontal direction and contacts the member on one side or the other. Calculate the reaction forces at the collar A and at the frictionless pin connection at O when the 3-kN load is applied.

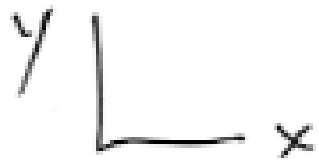
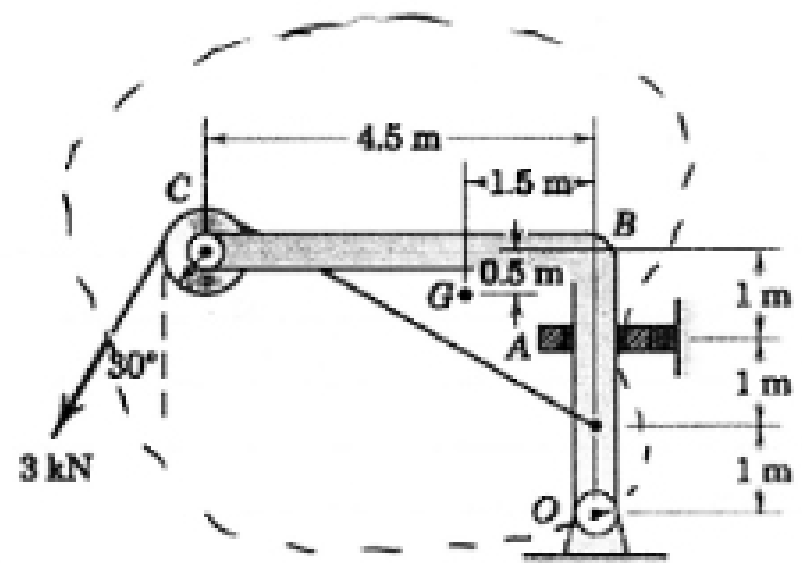

$$\rightarrow \sum F_x = 0 = -1500 + A_x - O_x$$

$$\uparrow \sum F_y = 0 = -2598 - 4905 + O_y$$

$$\therefore \boxed{O_y = 7503 \text{ N } \uparrow}$$

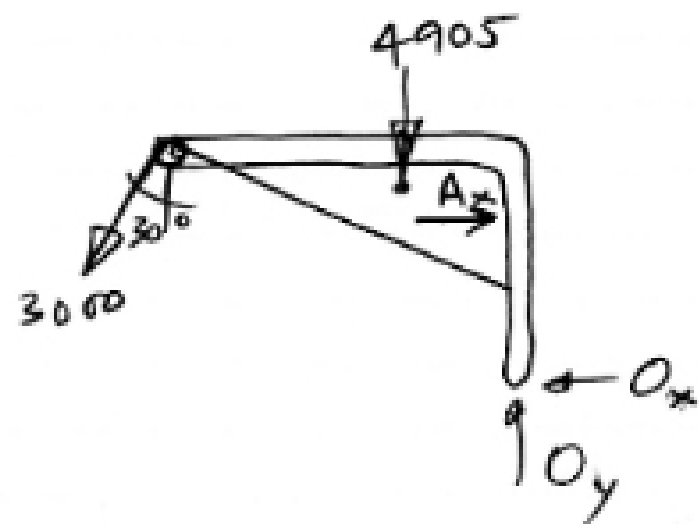

$$\curvearrow \sum M_o = 0 = 4905(1.5) + 1500(3) + 2598(4.5) - A_x(2)$$

$$\therefore \boxed{A_x = 11,774 \text{ N } \rightarrow}$$

$$\boxed{O_x = 10,274 \text{ N } \leftarrow}$$

2. (20 pts) The force P is applied to the 200-lb block A which rests atop the 100-lb crate. The system is at rest when P is first applied. The dimensions of the block and crate are negligible. Determine the forces between A and B and at the bottom of the crate B if (a) $P = 60$ lb, (b) $P = 80$ lb, and (c) $P = 120$ lb. If either body is not in equilibrium in either of the three load cases, calculate the accelerations of the bodies.

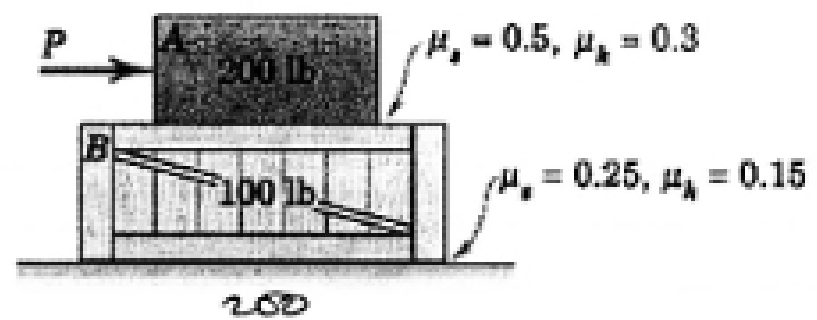

All cases:

$$F_{n_{AB}} = 200 \text{ lb}$$

$$F_{n_B} = 300 \text{ lb}$$

$$(F_{f_{AB}})_{\max} = .5(200) = 100 \text{ lb}$$

$$(F_{f_B})_{\max} = .25(300) = 75 \text{ lb}$$

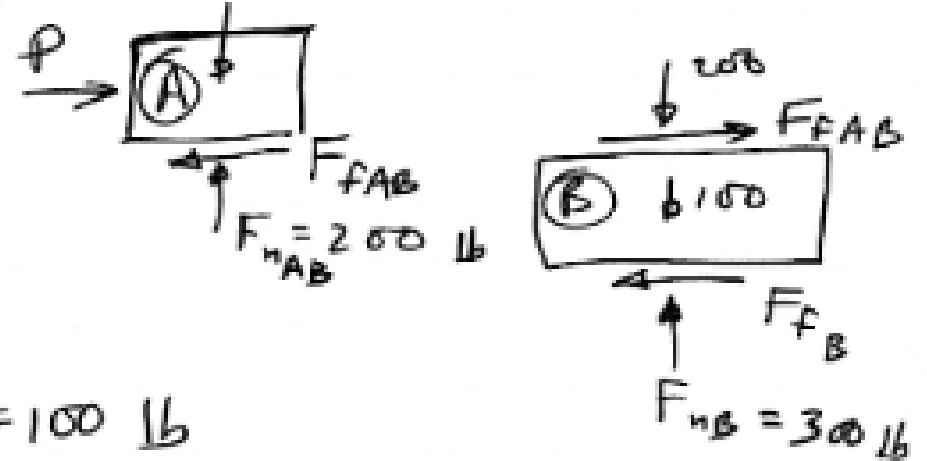

② $P = 60$:



Does \textcircled{A} slide on \textcircled{B} ?
 $\rightarrow \Sigma F_x = 60 - F_{f_{AB}} = 0?$

$$F_{f_{AB}} = 60 \text{ lb} < 100 \text{ lb}$$

$\therefore \textcircled{A}$ does NOT slide on B

Does \textcircled{B} slide on Floor

$$\rightarrow \Sigma F_x = 60 - F_{f_B} = 0?$$

$$F_{f_B} = 60 \text{ lb} < 75 \text{ lb}$$

$\therefore \textcircled{B}$ does NOT slide either

\therefore NO MOTION — equilibrium

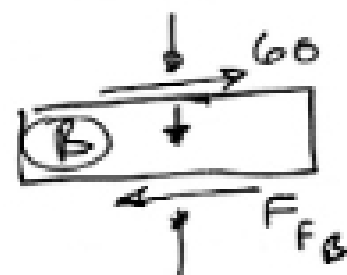

(b) $P = 80 \text{ lb}$

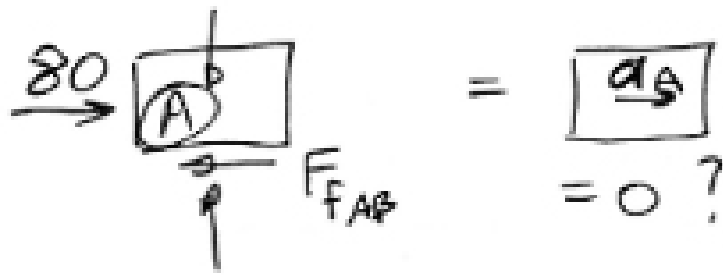

if $a_A = 0$

$F_{FAB} = 80 < (F_{FAB})_{\max}$

\therefore NO SLIDE ON (B)

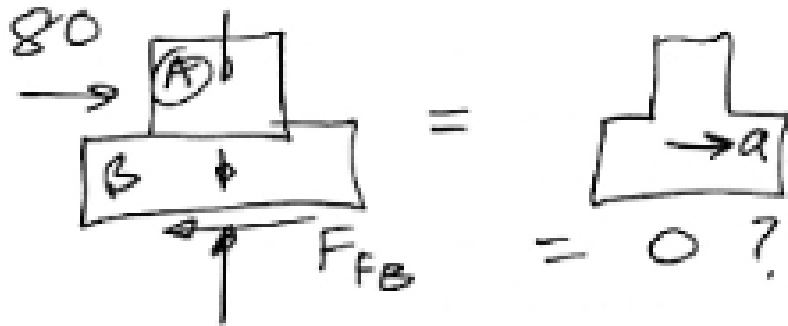

if $a_A > 0$

$F_{FAB} < 80 \therefore$ NO SLIDE ON (B)

if $a = 0$, $F_{FB} = 80 > (F_B)_{\max} = 75$

\therefore A & B slide together as one body

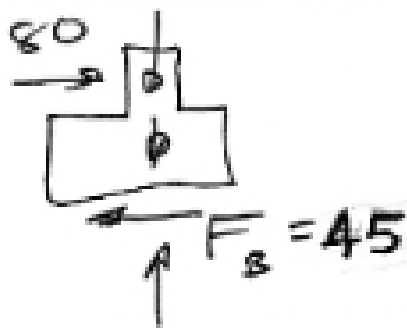

$F_{FB} = .15(300) = 45 \text{ lb}$

$\rightarrow \sum F_x = 80 - 45 = \frac{300}{32.2} a$

$a = 3.757 \text{ ft/sec}^2 \rightarrow$

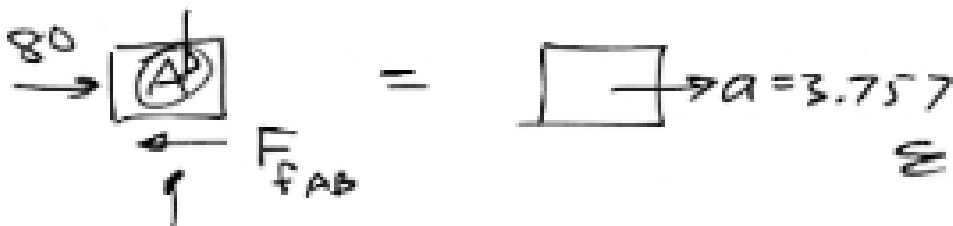

$\sum F_x = 80 - F_{FAB} = \frac{200}{32.2} (3.757)$

$F_{AB} = 56.66 \text{ lb}$