

# Power Semiconductor Devices

Xi Liu, *Department of Biomedical Engineering, University of Rochester*

**Abstract**—Classification, essential properties, important applications and development of power semiconductor devices will be explained. Some common power semiconductor devices, power metal oxide semiconductor field-effect transistor (MOSFET), thyristor and some new power devices will be described and discussed.

**Index Terms**—Power Semiconductor Devices, Thyristor, Power MOSFET.

## I. INTRODUCTION

Power semiconductor device has played an essential role in the development of power electronics as its key system topologies [1]. Compared to normal electronic devices, power semiconductor devices require large voltages in the off state and high current capability in the on state, which demand geometry differences from the low-power devices.

## II. COMMON POWER DEVICES

Power semiconductor can be divided into two main categories based on terminal numbers: two-terminal devices and three-terminal devices [2]. A second classification can be based on the device performance: majority carrier devices (Schottky diode, MOSFET) and minority carrier devices (Thyristor, bipolar transistor, IGBT), shown in Fig. 1. I will discuss the properties of several common power semiconductor devices in detail.

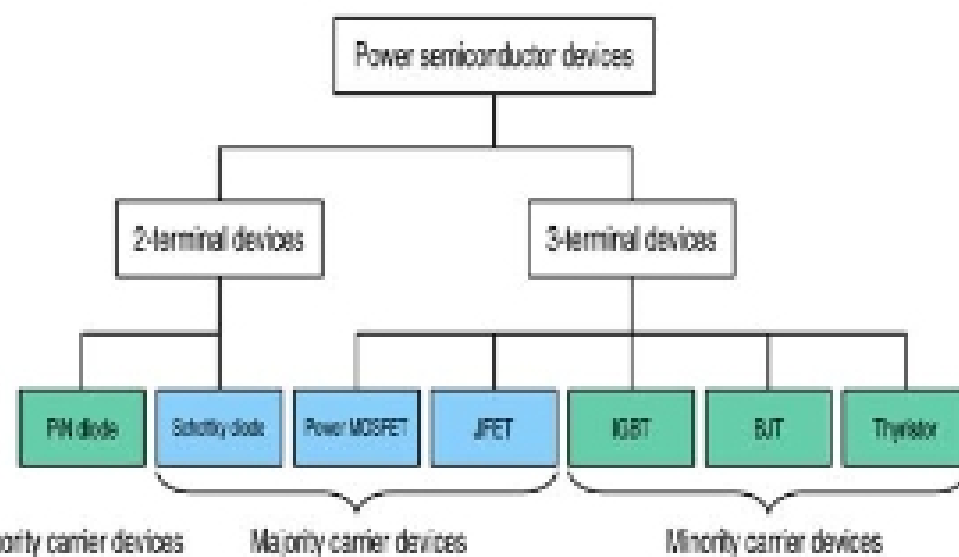

Fig. 1. The power devices family, showing the principal power switches

X. Liu is a graduate student in Department of Biomedical Engineering, University of Rochester, Rochester, NY 14627 USA (e-mail: liuxi@bme.rochester.edu).

### A. Power MOSFET

Power MOSFET has much higher current handling capability in ampere range and drain to source blocking voltage (50-100V) compared to other MOSFET. Large currents can be obtained with a large channel width, so power MOSFETs are fabricated with a repetitive pattern of small cells operating in parallel (Fig.2) [3].

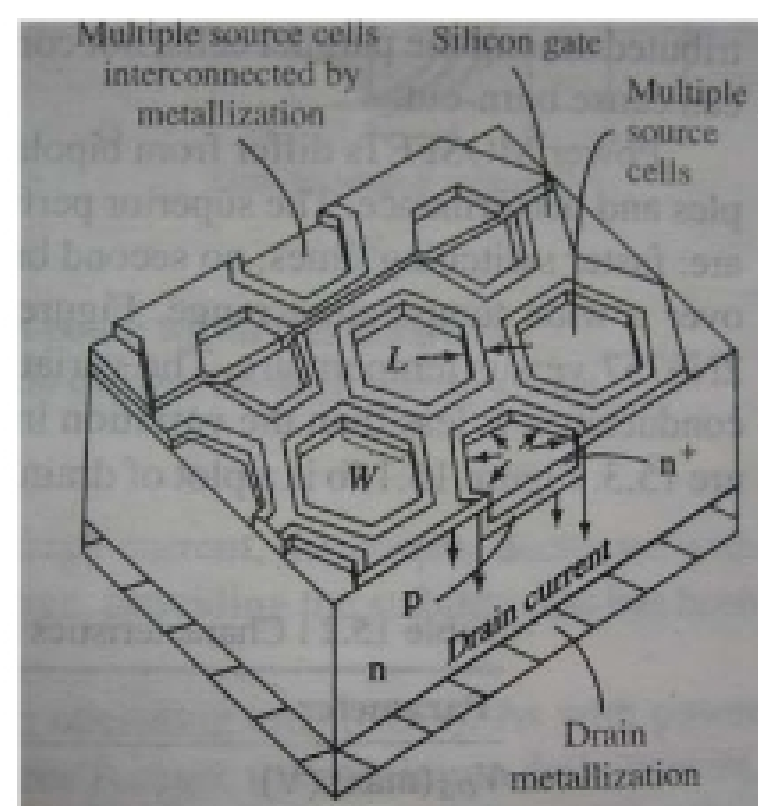

Fig.2 Repetitive pattern of the cells structure in power MOSFET

The input impedance of power MOSFET is extremely large, so given a very small control currents, relatively large currents can be switched between on and off states [4]. Thus, resistance is an important parameter for a power MOSFET, which can be written as

$$R_{on} = R_S + R_{CH} + R_D, \quad (1)$$

where  $R_S$ ,  $R_D$  are the resistance associated with the source contact and the drain contact respectively, and  $R_{CH}$  is the channel resistance. In linear region of operation,  $R_{CH}$  can be written as

$$R_{CH} = \frac{L}{W \mu_n C_{ox} (V_{GS} - V_T)} \quad (2)$$

From the equation above, we can find if the current in any particular cell begins to increase, the resulting temperature rise will increase the on-resistance, thus limiting the current. The "on-resistance" characteristic as a function of drain current is

shown in Fig. 3, which provides stability for the power MOSFET.

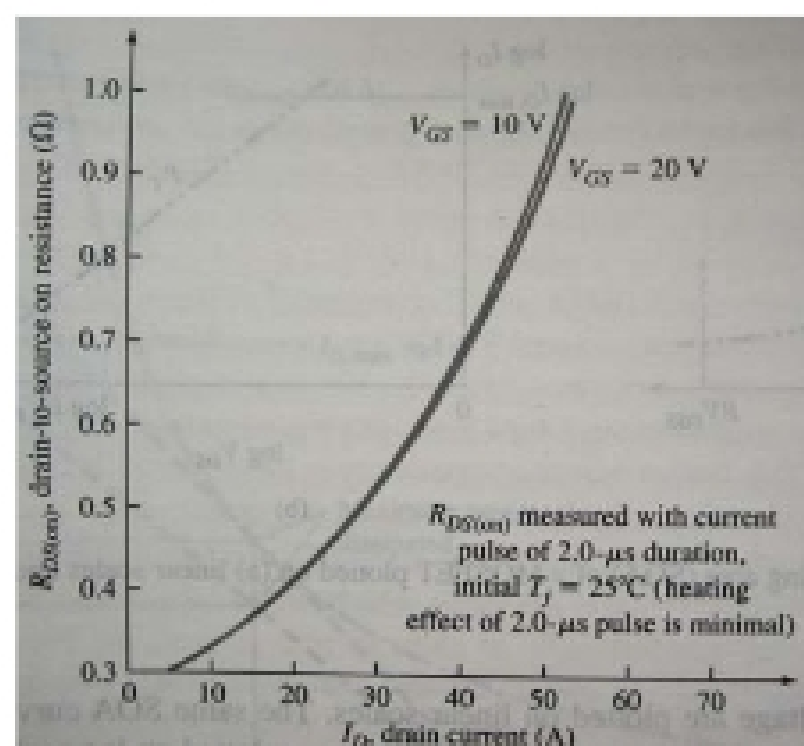

Fig. 3. Typical drain-to-source resistance versus drain current characteristics of a MOSFET.

### B. Thyristor

Thyristor is a general class of a four-layer pnpn semiconducting device, which exhibits bistable regenerative switching characteristics [3]. The structure of thyristor, which has three pn junctions, can be modeled as coupled npn and pnp bipolar transistor (Fig.4).

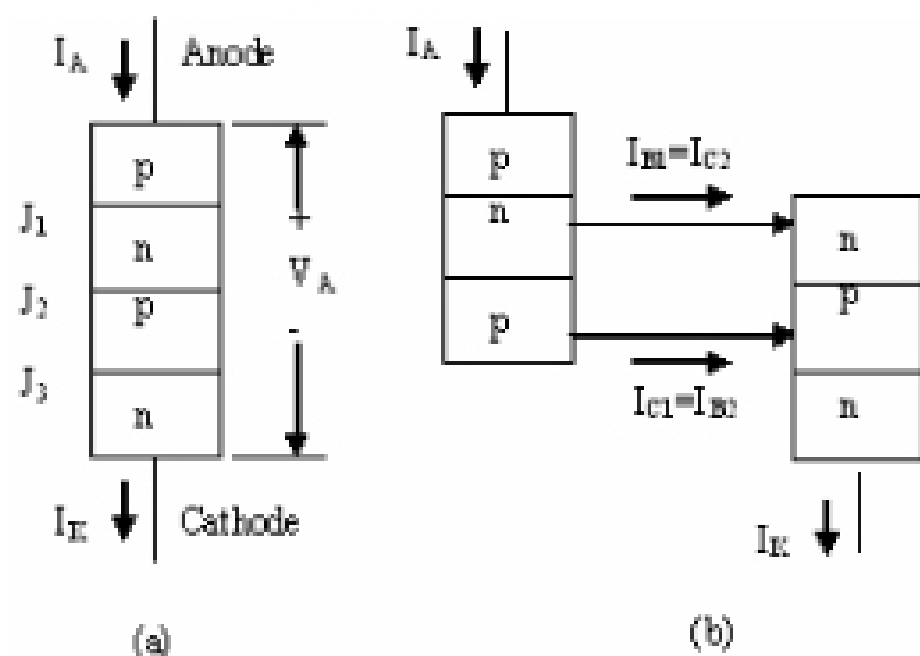

Fig. 4 (a) The basic four-layer pnpn structure. (b) Two two-transistor equivalent circuit of the four-layer pnpn device.

So the anode current  $I_A$  can be written as

$$I_A = \frac{I_{C01} + I_{C02}}{1 - (\alpha_1 + \alpha_2)}, \quad (3)$$

where  $I_{C01}$  and  $I_{C02}$  are the reverse B-C junction saturation currents of the pnp and npn transistors, and  $\alpha_1, \alpha_2$  are the common base currents gain in the two devices.

The current voltage characteristic of the pnpn device is shown in Fig.5. There are three states: forward conducting, reverse blocking and forward blocking. For a small value of  $V_A$ , the collector current in each device is the reverse saturation

current. If  $V_A$  is large enough to cause  $J_2$  junction to breakdown,  $I_A$  will increase rapidly and have a regenerative positive feedback. As  $I_A$  increases, two equivalent bipolar transistors are driven into saturation and the junction  $J_2$  becomes forward biased. The total voltage decreases and the voltage drop across may increase slightly if the current keeps increasing.

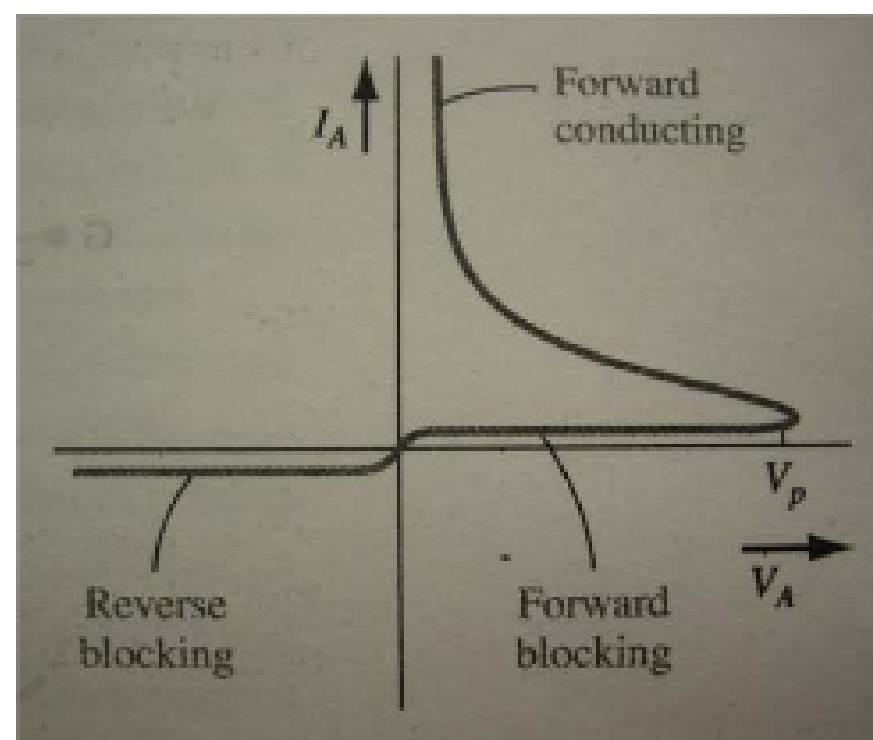

Fig. 5 The current-voltage characteristics of the pnpn device.

Thyristor is a device that will remain in a blocking state until switched to the low-impedance state by a control signal, which then does not necessarily have to remain on, which can be used as a efficient switch for a large currents at low frequencies.

### III. APPLICATIONS

Power semiconductor devices have widespread applications in three major consumer markets: automotive, entertainment and appliance [4], e.g. high-voltage power transistors phase into television or alternator regulators switch to large area integrated circuitry. Automotive industry is one of the most important applications of power semiconductor devices (Table 1).

Nowadays, automotive industry requires the diagnostic capability and switch-mode regulation [5]. Intelligence electronics, fulfilling the requirement of both high current and low resistance, are important. The multichip approach offers flexibility and gives cost-effective power switching for higher current switches. TLP410 is an example shown in Fig 6. It is designed specifically for automotive high-sided switching up to 6A of lamp, solenoid, relay and motor loads. It features high current gain and low leakage characteristics. A temperature sense diode is built into the power transistor.

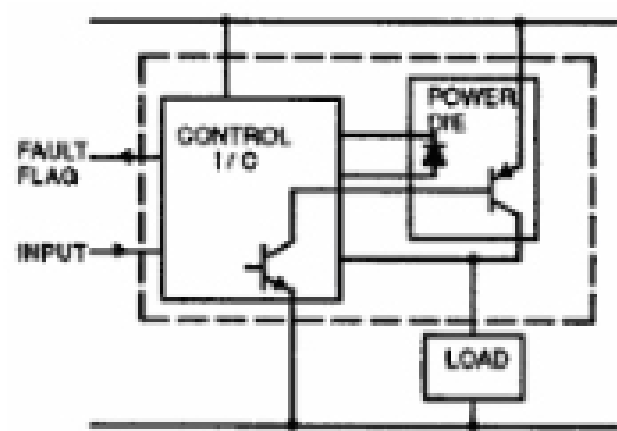

Fig. 6. TLP 410 multidiode headlamp driver.

Table. 1. Power Devices in automotive systems.

Present Applications	Device	Future Applications [23], [24]
Alternator	Rectifier	Same as present
Regulator—field switch	Power transistor	Integrated circuit
Ignition—coil switch or for CDI; inverter and capacitor switch	Power transistor and SCR	Same as present
Radio/stereo tape	Power transistor	Probably going to integrated circuit
	Power transistor or SCR	Sequential flasher
	SCR	Windshield wiper
	SCR or TRIAC	Remote switching system (single wire harness in ac car)
	Power transistor	Inverter in ac car
	SCR or power transistor	All-electric car pulse width or cycloconverter speed control
	SCR or power transistor	Comfort controls

#### IV. FUTURE DEVELOPMENTS

For future power conversion applications, new structures or semiconductor materials can be investigated for prospective power semiconductor devices.

##### A. Structure Improvement

Insulated gate bipolar transistor (IGBT), static induction transistor (SIT) and MOS-controlled thyristor (MCT) [1] are three new structure of power devices. IGBT is most common used power electronic devices nowadays, whose structure is shown in Fig. 7.

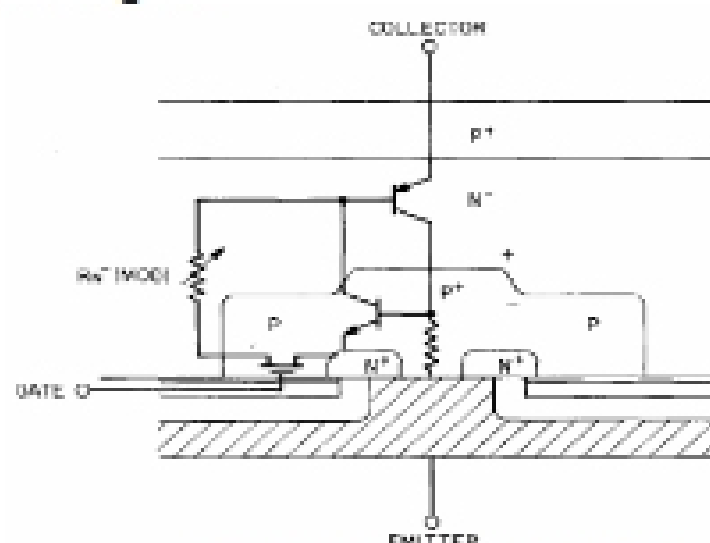

Fig. 7. Basic Structure of IGBT

An IGBT is basically a hybrid MOS-gated turn on/off bipolar transistor that combines the attributes of a MOSFET, BJT, and thyristor. A SIT is a high-power high-frequency device and is essentially the solid-state version of a triode vacuum tube. An MCT is a thyristor like trigger-into-conduction device that can be turned on or off by a short pulse on the MOS gate. It is a high-power high-frequency low conduction drop switching device.

##### B. Materials Improvement

In previous discussion, I mainly focused on the prospects of silicon based power semiconductors. However the silicon based power switching devices are reaching fundamental limits imposed by the low breakdown field of the material. Silicon carbide, with a higher field characteristic, is a promising choice for high power, high temperature and high frequency applications [6] due to the reasons below:

- 1) SiC has a high electric breakdown property, which will support a very voltage across a thin layer.
- 2) SiC has a high carrier drift velocity, which is essential for high frequency operation particularly for minority carrier driven bipolar devices.
- 3) SiC has a high thermal conductivity realizing high temperature operation and better thermal management of power control applications.
- 4) The native oxide of SiC being SiO<sub>2</sub>, the same oxide as silicon, the whole family of MOS gated power devices used in silicon, i.e. the power MOSFET and the IGBT, can all be fabricated in SiC.

Due to the superior material properties, SiC power devices can give a much better performance than silicon power devices, e.g., the on-resistance of SiC can be 700 times lower than similar silicon devices.

#### V. CONCLUSION

From the discussion above, we can find that development of power semiconductor devices is very essential for modern electronics devices. The new power devices based on new structure, e.g., IGBT, have been widely used. Some new material, SiC, is a promising candidate and commercially realistic.

#### REFERENCES

- [1] Bose, B.K., "Evaluation of modern power semiconductor devices and future trends of converters," IEEE Transactions on Vol. 28, pp. 403 - 413, 1992
- [2] B. Jayant Baliga, *Power Semiconductor Devices*, (PWS publishing Company, Boston, 1996).
- [3] Donald A. Neaman, *Semiconductor Physics and Devices: Basic Principles*, (McGraw-Hill Companies, 2003), Chap. 15.
- [4] Ralph Greenburg, "Consumer Applications of Power Semiconductors", Proceedings of the IEEE, Vol. 55, pp. 1426-1434, 1967.
- [5] Andrew Marshall, Kenneth G. Buss, "Automotive semiconductor switch technologies", Electronic Applications in Transportation, 1990. IEEE Workshop on 18-19, pp. 68 - 72, 1990
- [6] Gourab Majumdar, "Future of power semiconductors" PESC 04. 2004 IEEE 35th Annual Vol. 1, pp. 10 - 15, 2004