

## Concurrent processes and real-time scheduling

55:036  
Embedded Systems and System Software

## Concurrency in Embedded Systems

- Often, an embedded system must carry out more than one task simultaneously
  - monitoring multiple sensors
  - controlling multiple devices
  - etc.
- A single embedded processor may be responsible for multiple tasks
- An embedded system may utilize multiple embedded processors

## Simple Example of Concurrency in Embedded Systems

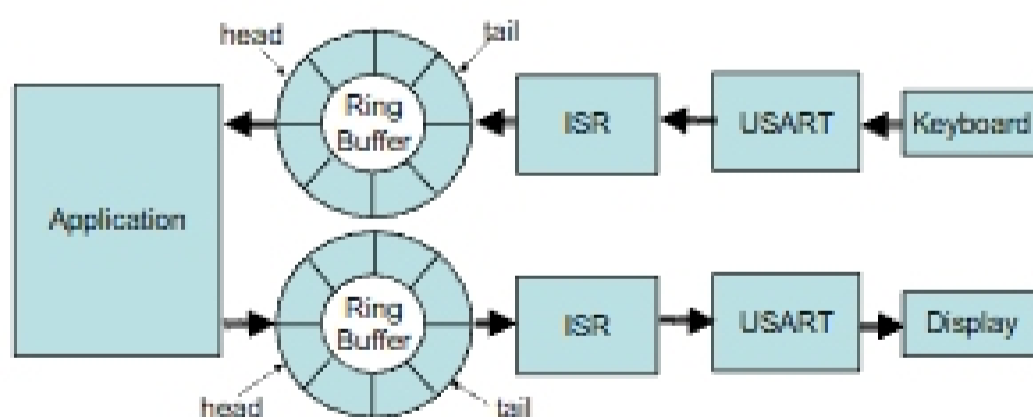

## Concurrency Pitfalls—An Example

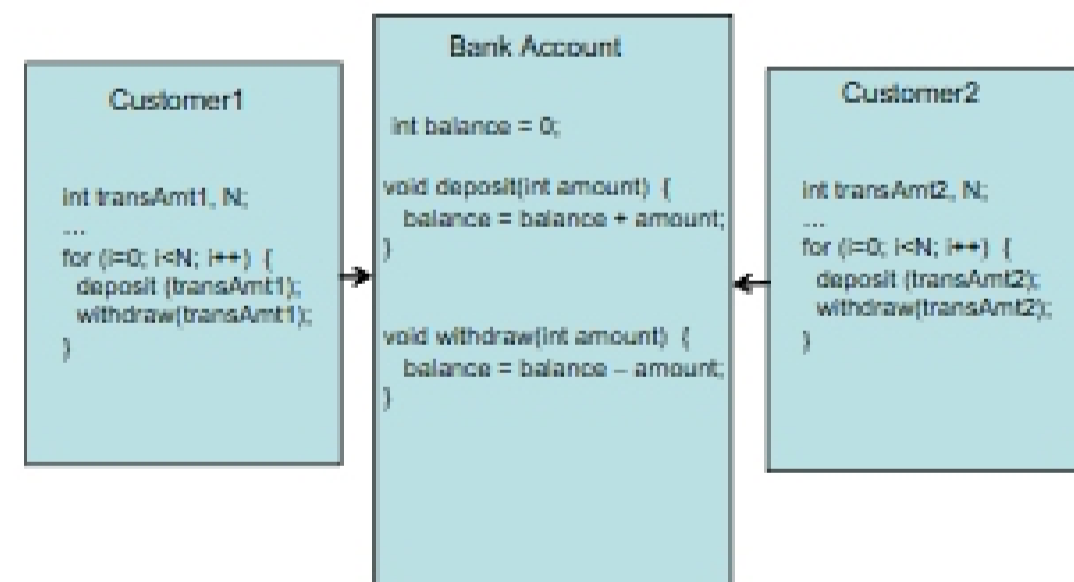

## Concurrency Pitfalls—An Example

1. read (old) balance
2. add amount to balance
3. write updated balance

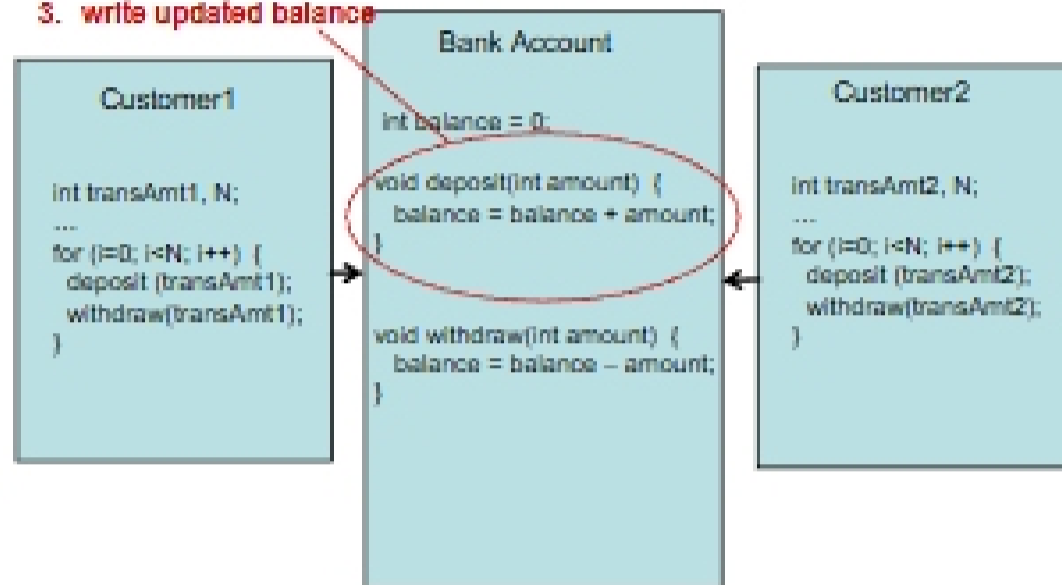

## Concurrency Pitfalls—An Example

1. read (old) balance
2. add amount to old balance
3. write updated balance

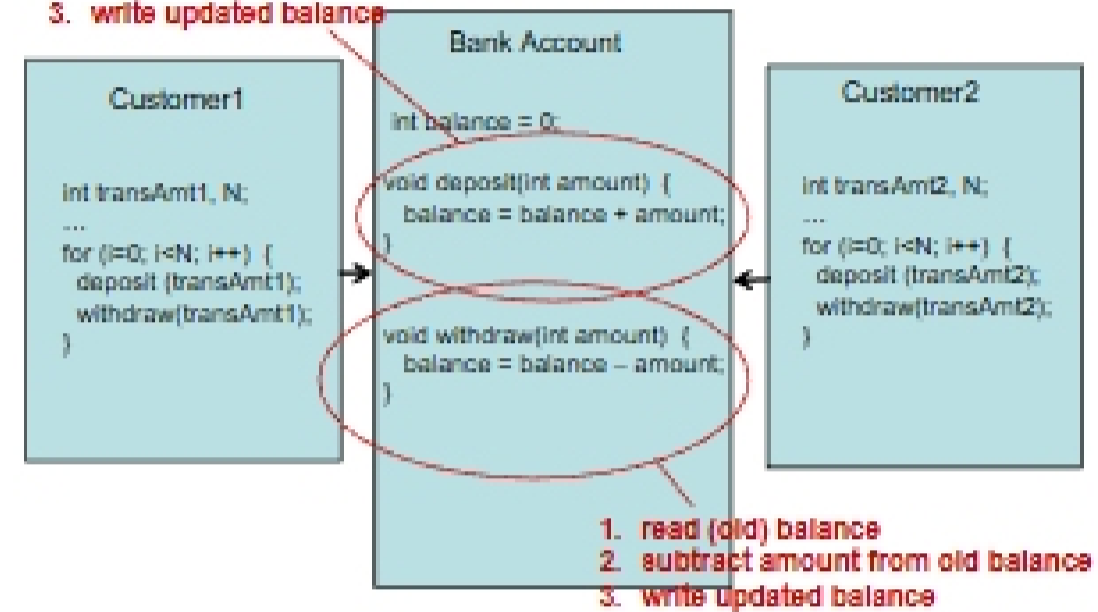

1. read (old) balance
2. subtract amount from old balance
3. write updated balance

## Concurrency Pitfalls—An Example

1. read (old) balance
2. add amount to old balance
3. write updated balance

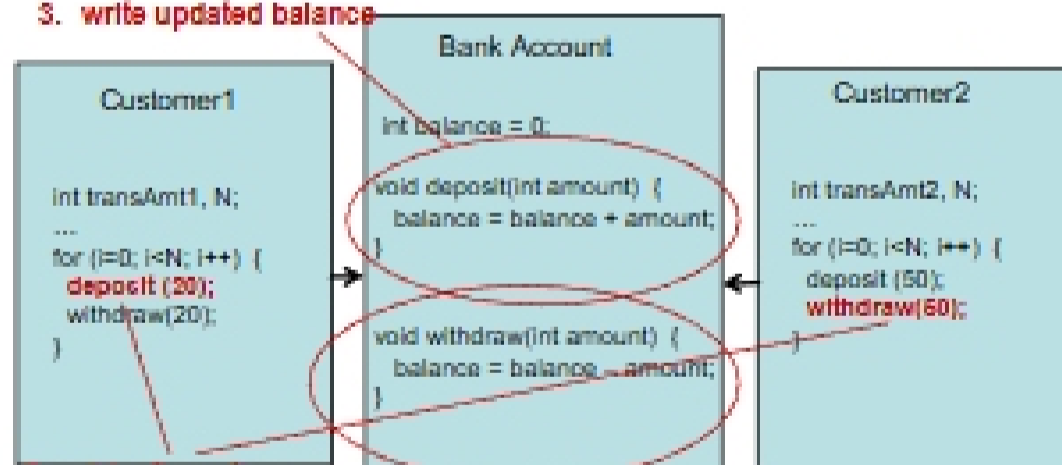

Consider these two operations being performed concurrently. Net Result: Balance should be reduced by \$30

1. read (old) balance
2. subtract amount from old balance
3. write updated balance

## Concurrency Pitfalls—An Example

1. read (old) balance
2. add amount to old balance
3. write updated balance

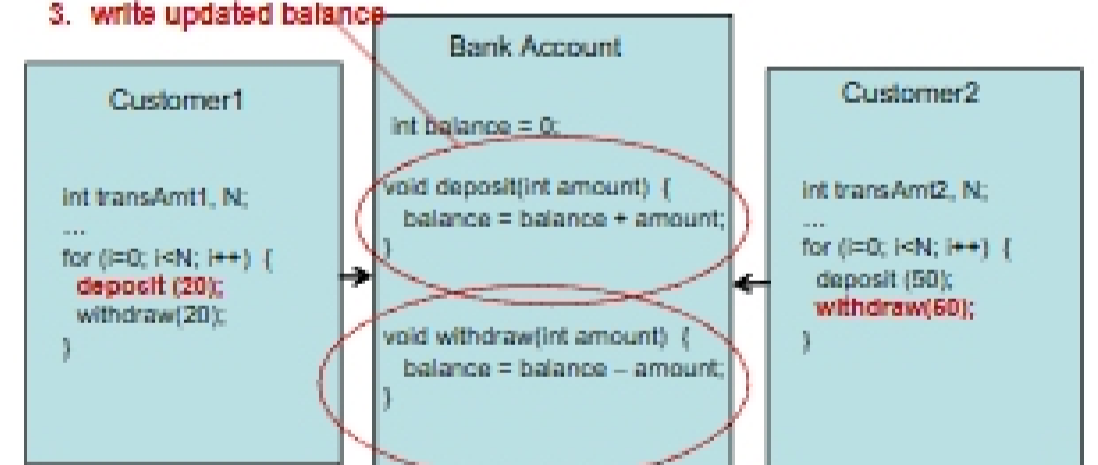

1 e.g. old balance = \$100

1. read (old) balance
2. subtract amount from old balance
3. write updated balance

