

Field Effect Transistors and Op Amps I

The Field Effect Transistor

This lab begins with some experiments on a junction field effect transistor (JFET), type 2N5458 and then continues with op amps using the TL082/084 dual/quad op amp chips. Details of these devices, including pin-out, can be found on the data sheets in the supplementary reading section on your web page. Items marked with an asterisk (*) should be done before coming to lab.

Pinch-off bias

Set up the circuit below. Use the LabView program JFET.vi to measure the drain current I_D as a function of the Gate-Source voltage V_{GS} . Remember that the variable gate voltage is negative and you should keep it in the range 0 to 5V. You should find that the drain current decreases with the gate voltage until a point where it is essentially zero. This is the so-called pinch-off voltage.

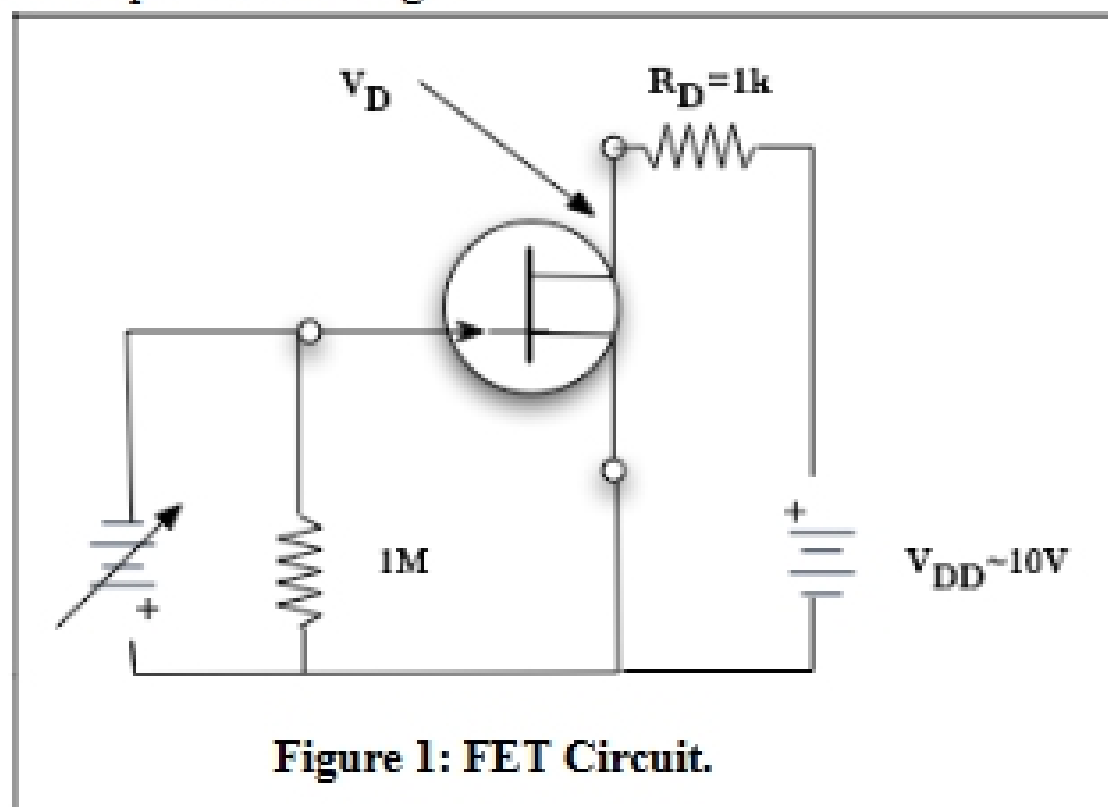

Figure 1: FET Circuit.

Compare your answer for the pinch-off voltage with the rather liberal limits given on the data page for “Gate-Source Cutoff Voltage”.

Common-source transfer characteristics

The program measures the current by measuring the voltage drop across the 1kΩ drain resistor. Make a copy of the computer plot of drain current vs. gate-source voltage and paste it into your notebook. Compare your plot to the one in the data sheet. Are the plots similar? Does your plot have the right curvature? The plot should have the form:

$$I_D = I_{DSS} \left(1 - \frac{V_{GS}}{V_p} \right)^2$$

where I_D is the drain current and V_{GS} the Gate-Source voltage. From your plot determine the parameters I_{DSS} and V_p .

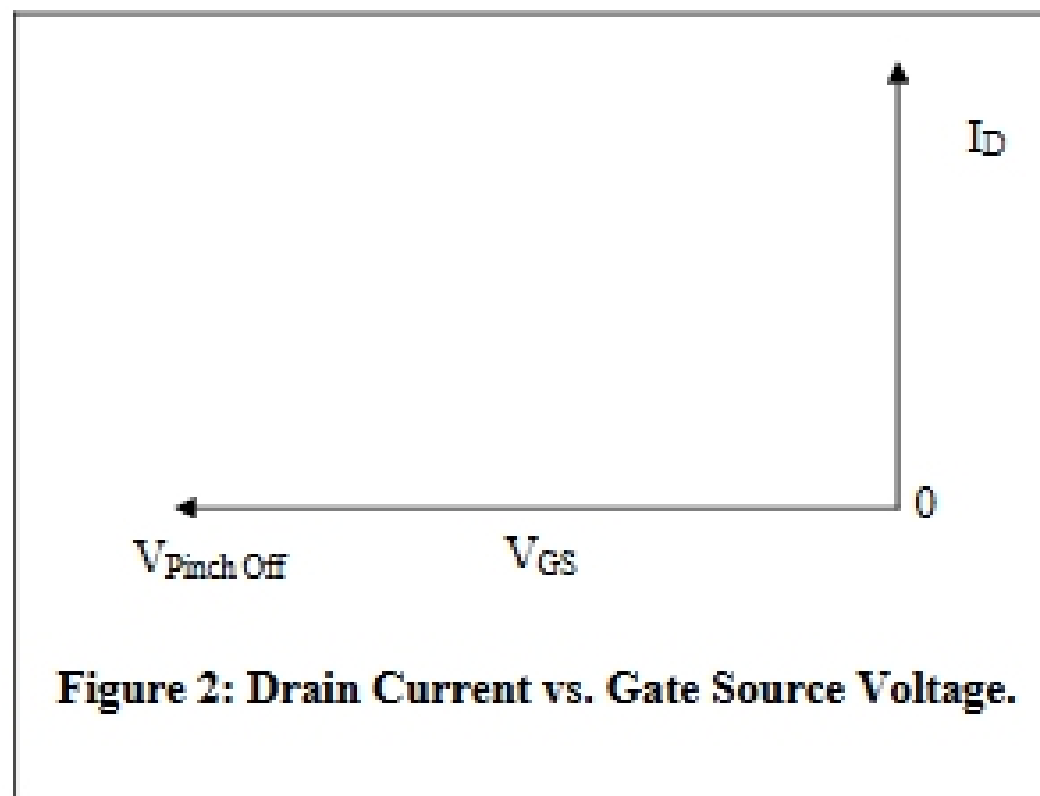

Self-bias

Redo the circuit replacing the computer-generated voltages with a power supply for V_{DD} and a signal generator for the variable input voltages as shown in Figure 3. Choose values for R_D and R_S to give the following circuit a good operating point. For a good operating point, the drain voltage is between 3 and 7 volts. Note that the AC signal on the input is not relevant in determining the operating point and may be disconnected for this part.

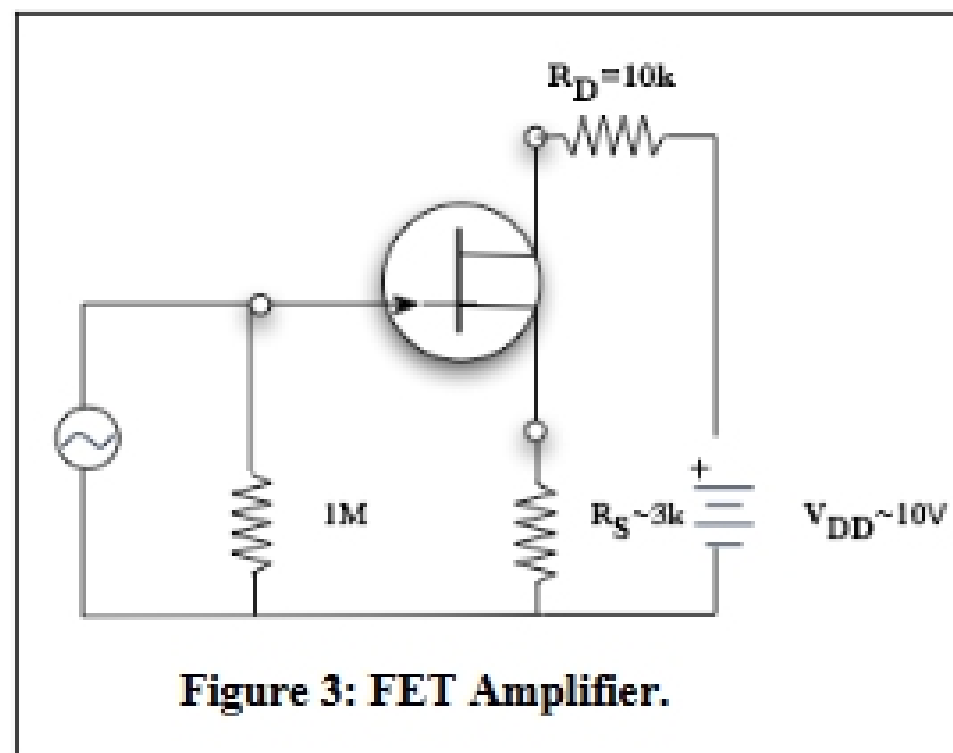

Amplifier

The circuit above is an amplifier. The output signal at the drain will be larger than the input signal on the gate.

- (a) *Explain why this is an inverting amplifier.
- (b) The gain of the amplifier depends upon the transconductance g_m . From your earlier measurements determine the value of $g_m = \Delta i_D / \Delta V_{GS}$ at your operating point. The units of this parameter are mhos or reciprocal ohms.
- (c) *The gain is defined as $G = V_{out} / V_{in}$

Show that:
$$G = \frac{g_m R_D}{1 + g_m R_S}$$

And therefore that you expect a gain of about 2.5 if $g_m = 1 \times 10^{-3}$ mhos, $R_D = 5k\Omega$ and $R_S = 1k\Omega$.

- (d) Measure the gain of your amplifier circuit and compare with expectation.

Op Amps I

Build the circuits below using the TL082 dual or TL084 quad op amp. Remember to connect ± 15 volt supplies to the chip. Make sure that the indicated grounds include your power supply ground.

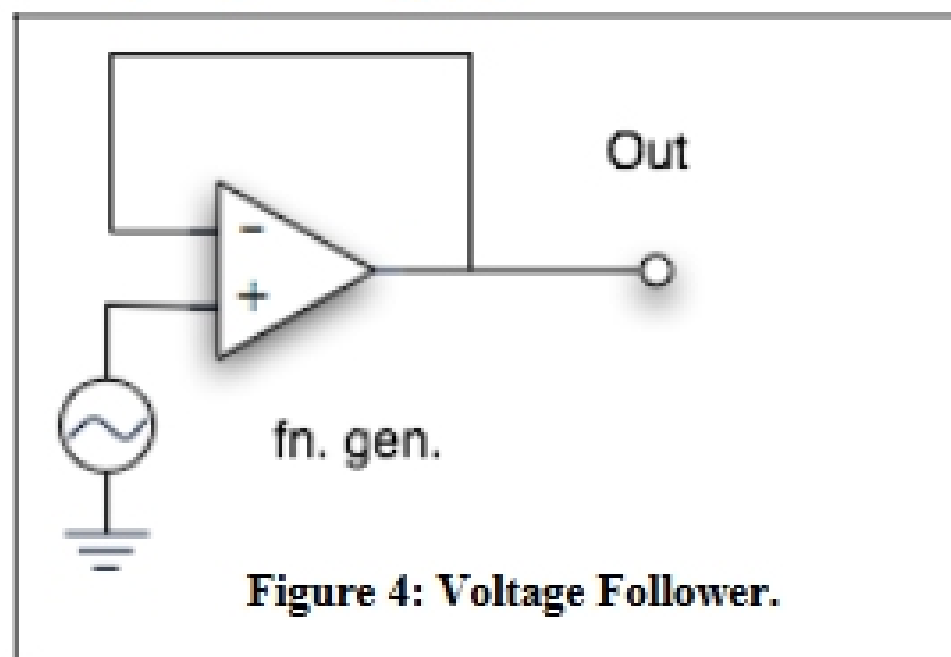

The voltage follower

- (a) Use an oscilloscope to compare the input and output. Are they the same? Include a copy of the DPO output showing input and output wave forms.
- (b) Make the input zero volts by grounding it. Use a DMM to discover whether the output is precisely zero volts. Possible the output will be a few millivolts. That represents offset within the op amp.