

Bipolar Transistors II

Transistor circuits can be used to obtain stable sources of constant voltage. The following sections trace the development of a simple voltage source using a single transistor. Items marked with an asterisk (*) should be done before coming to lab.

The pass transistor

Build the emitter follower circuit below, called the “pass-transistor” circuit.

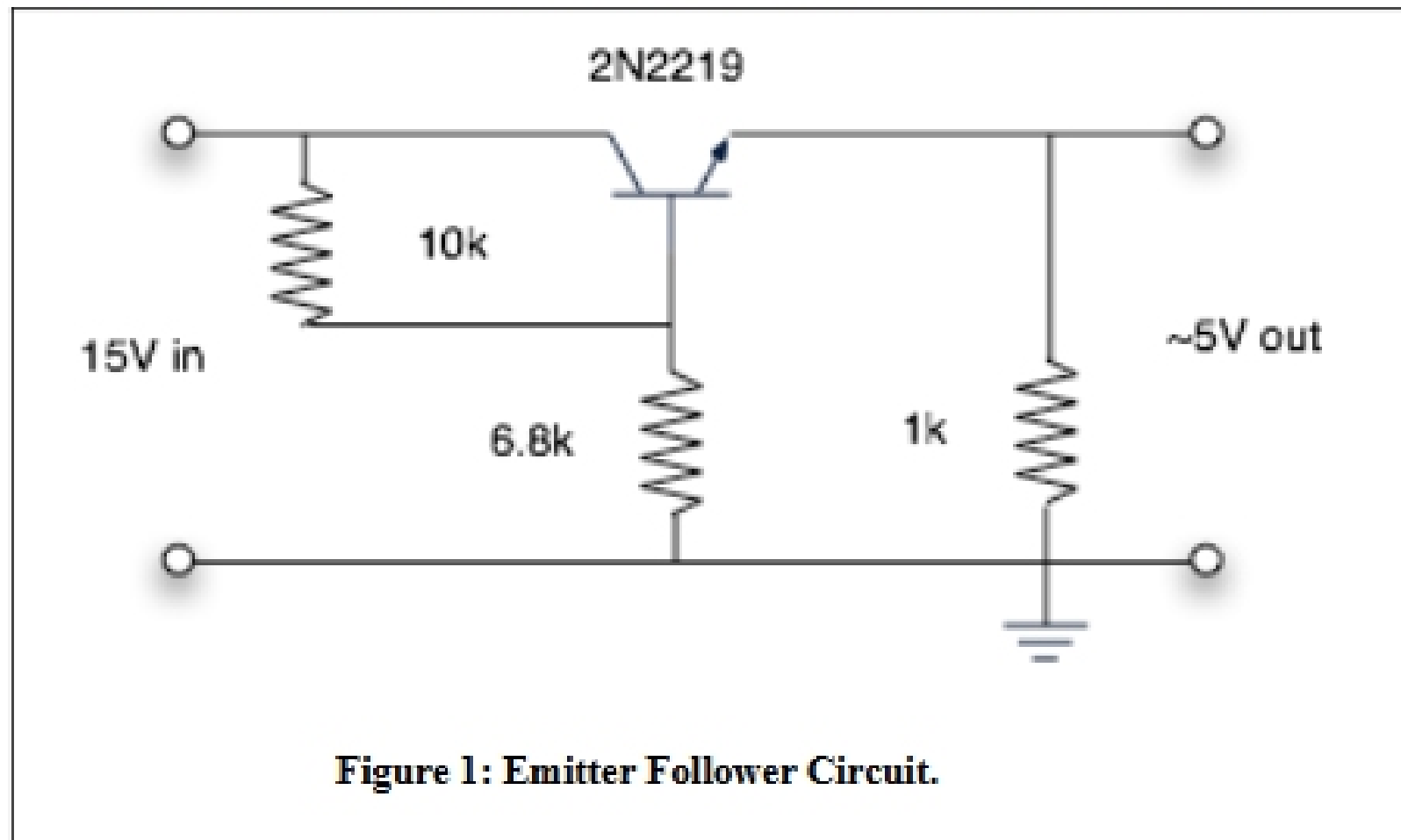

- *Calculate the output impedance of the transistor, assuming $\beta=200$. Hint: As you have seen in lecture, it is approximately equal to the input impedance divided by β . The input impedance involves the 10k and 6.8k
- Measure the output impedance by finding the change in voltage when the circuit is loaded by 150 ohms.
- Reduce the input voltage from 15 volts to 10 volts, a 33% change. What is the percentage change in the output voltage?

The Zener-regulated pass transistor

Replace the 6.8k resistor by a reverse-biased 5.6 volt Zener diode (Fig. 2).

- Measure the output impedance as above.
- Find the change in output voltage when the input voltage changes from 15 to 10 volts.

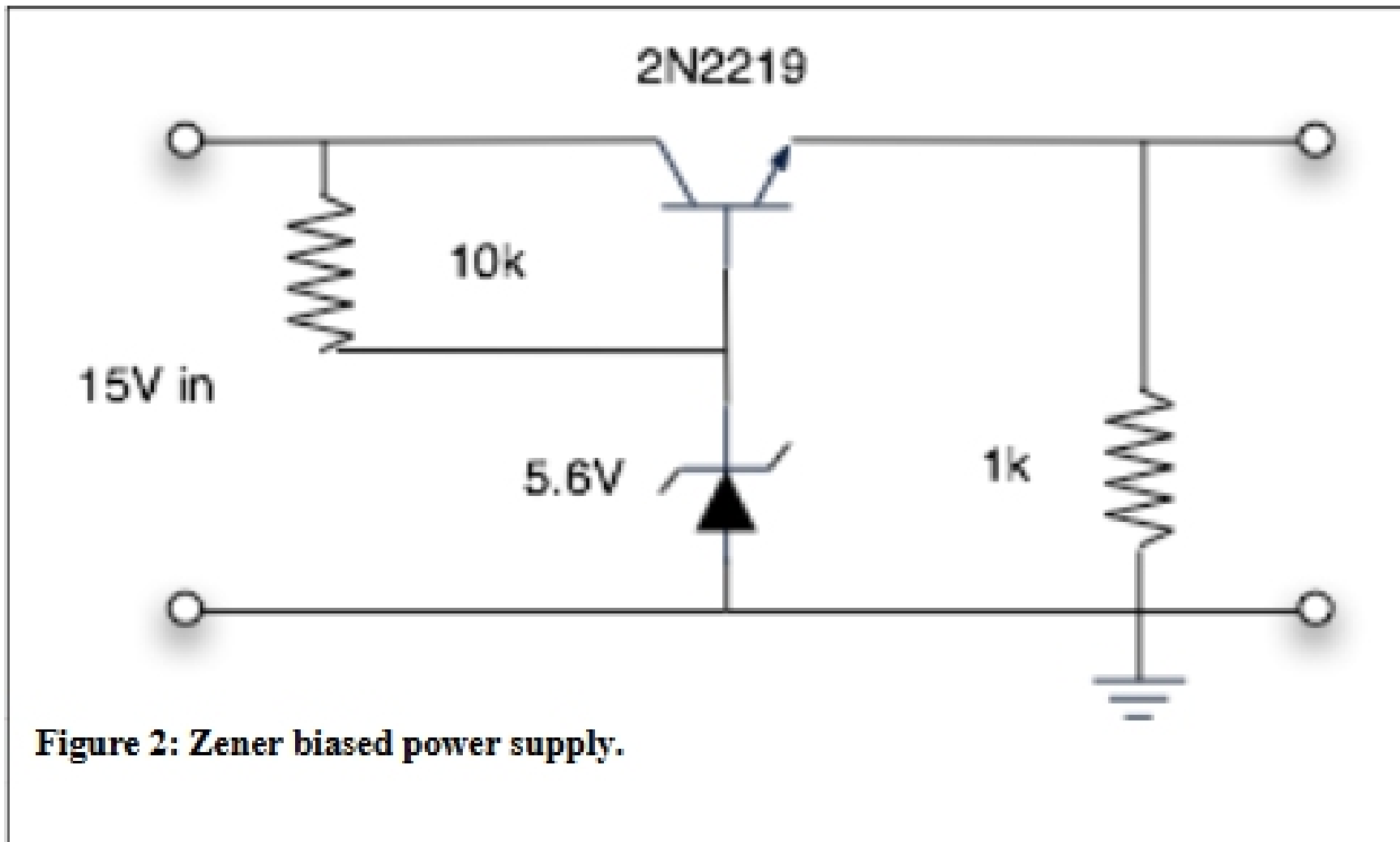

Figure 2: Zener biased power supply.

Construction of a power supply

On a piece of perforated board solder together the following circuit:

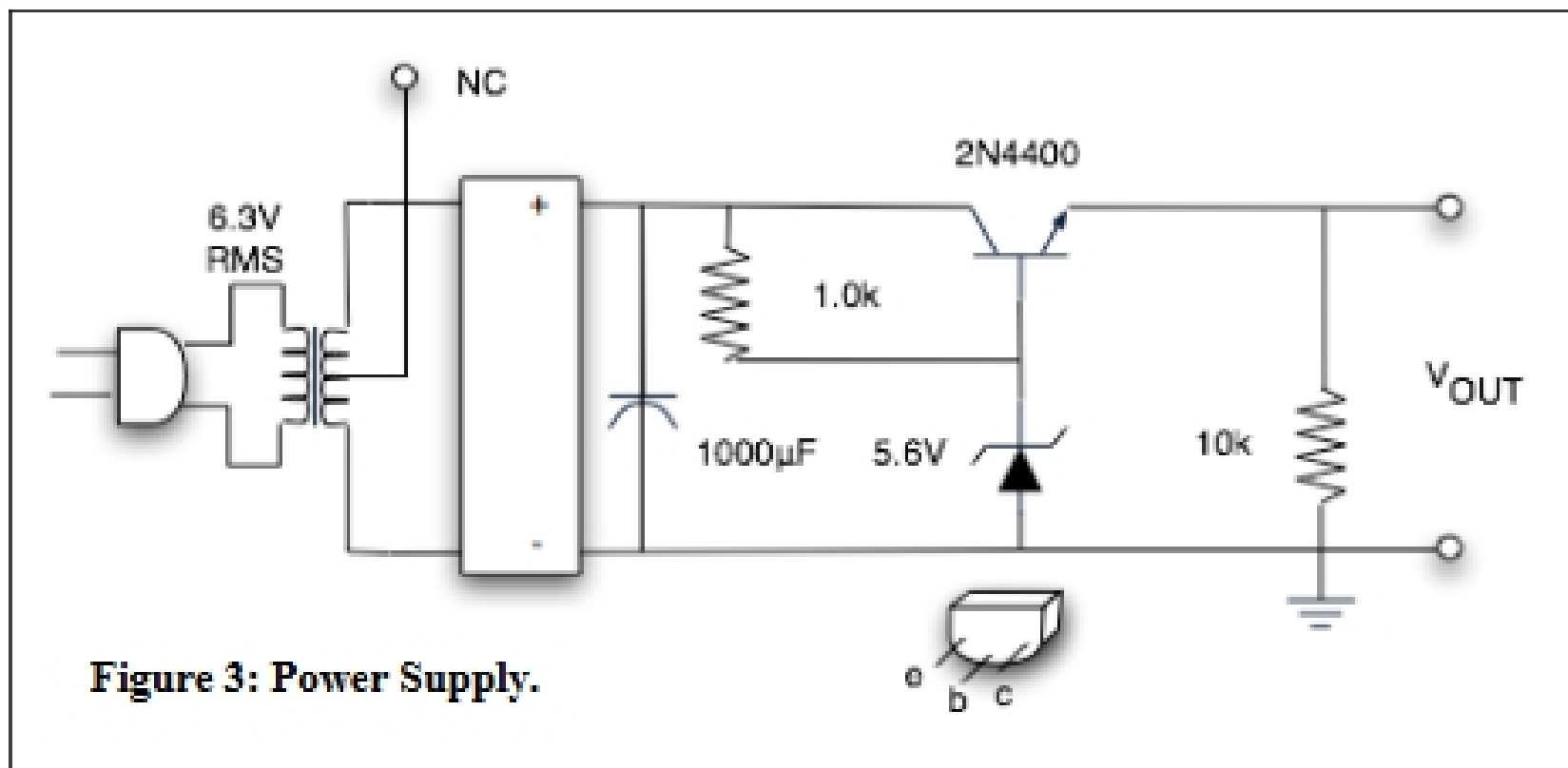
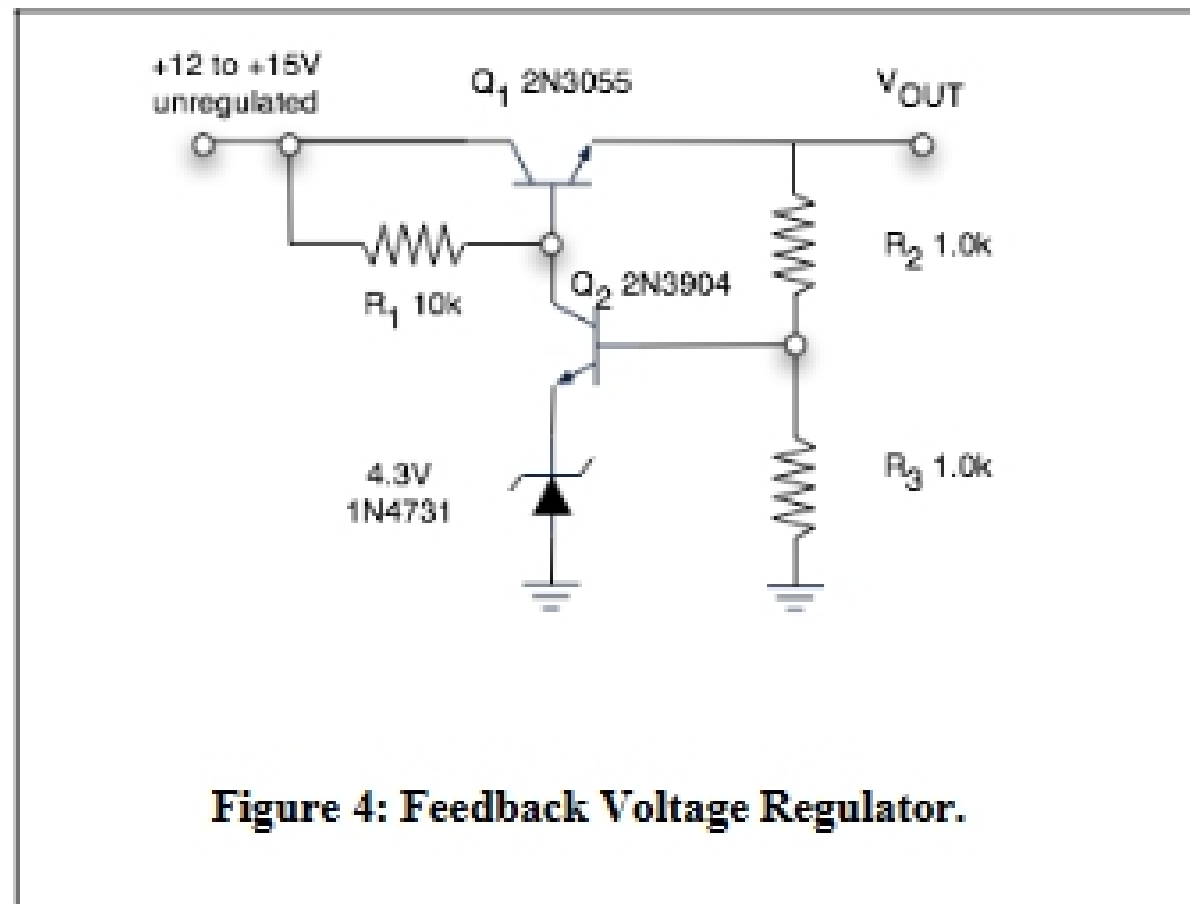

Figure 3: Power Supply.

The rectangular box refers to the full-wave rectifier WL02F, and "NC" means no connections to the center tap on the transformer. The output should be about 5 volts.

Plot V vs. I for this supply by loading it. Choose several load resistors from $2k\Omega$ to 100Ω . As the current increases do you note any change in the curve? If yes, comment on possible reasons.

Note: The zener-regulated pass transistor developed in this lab is an acceptable source of stable voltage to be used when circumstances are not demanding. Transistorized power supplies with two or three transistors in a fast negative feedback circuit are used when the



load conditions are variable. These can give output impedances less than an ohm and high stability against temperature variation. Figure 4 is a common example of a negative-feedback circuit. Transistor Q_1 is normally conducting because of the bias current through R_1 . When the output voltage reaches 10 volts, Q_2 begins to conduct, shunting current away from the base of Q_1 and preventing further rise of the output voltage. *Explain why this happens.