

Circuits II

EE221

Unit 10

Instructor: Kevin D. Donohue

Magnetically Coupled Circuits, Linear
Transformers, Transformer Circuits

Coupling Coefficient

The coupling coefficient is a measure of the percentage of flux from one coil that links another (mutual inductance) coil. The coupling coefficient for 2 mutual inductors is given by:

$$k = \frac{M}{\sqrt{L_2 L_1}}$$

If $k > 0.5$, then most of the flux from the one coil links the other and the coils are said to be *tightly coupled*. If $k < 0.5$, then most of the flux is not shared between the 2 coils and in this case the coils are said to be *loosely coupled*.

Linear Transformers

A transformer is a 4-terminal device comprised of 2 or more magnetically coupled coils.

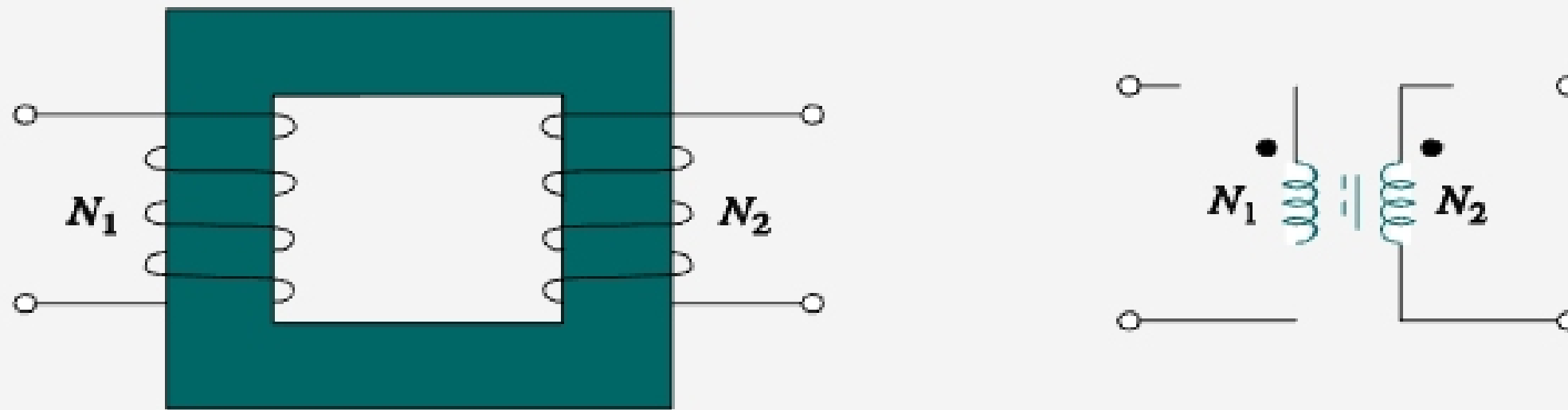

In a typical application they are used to change the ratio of current to voltage (maintaining constant power) from a source to a load.

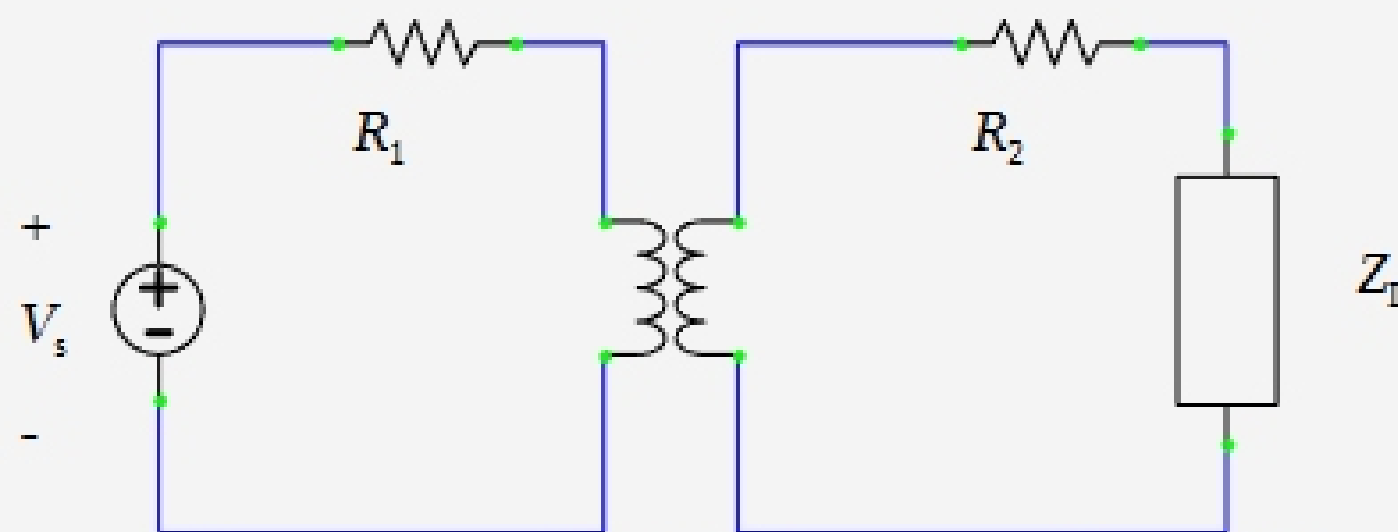

Primary Coil Secondary Coil