

Reading Assignment: Chapter 1 in *Electric Circuits, 9th Edition* by Nilsson

Chapter 1 - Circuit Variables

Five key quantities are introduced in this chapter:

- charge, q
 - current, I
 - voltage, v
 - power, p
 - energy, w
- introduced last class
- introduced this class

Voltage – change in energy with respect to charge

$$v(t) = \frac{dW}{dq} \quad \text{in units of} \quad \frac{\text{joules}}{\text{coulomb}} = \text{volts, V} \quad (\text{so } 1\text{V} = 1\text{J/C})$$

- The definition above is not generally familiar to the layman
- voltage is also referred to as **potential difference**
- voltage should always be expressed with a polarity (+ and - terminals)

Polarity: voltage should always be expressed with a polarity (+ and - terminals)

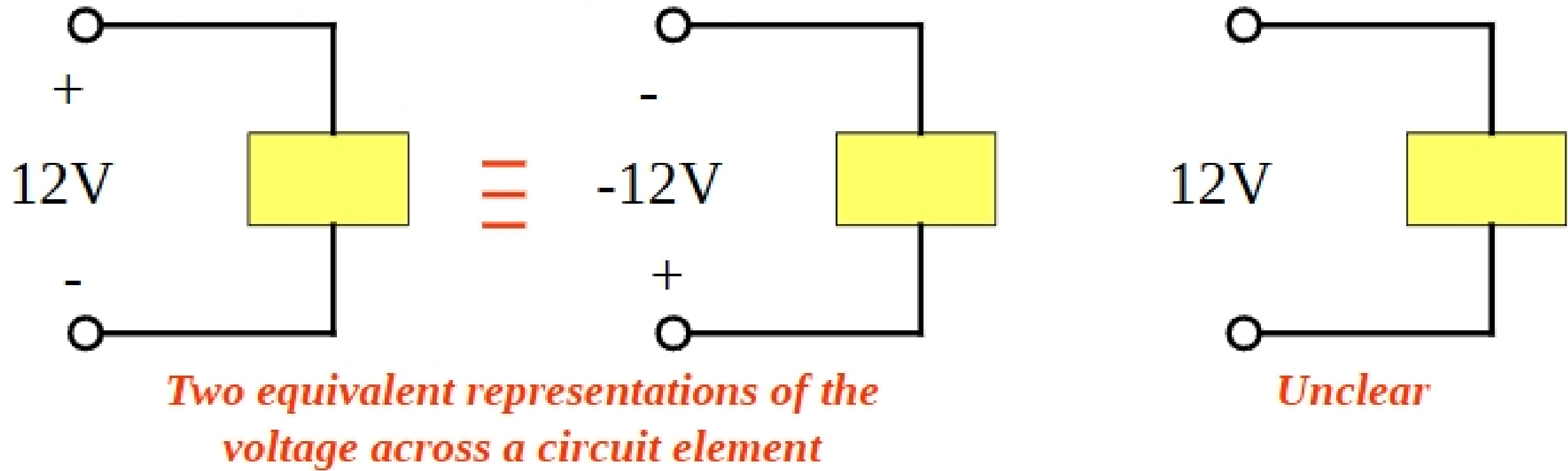

If $1V = 1 J/C$, then 1V of potential difference exists across an element if 1J of energy is expended in passing 1C of charge through the element as illustrated below:

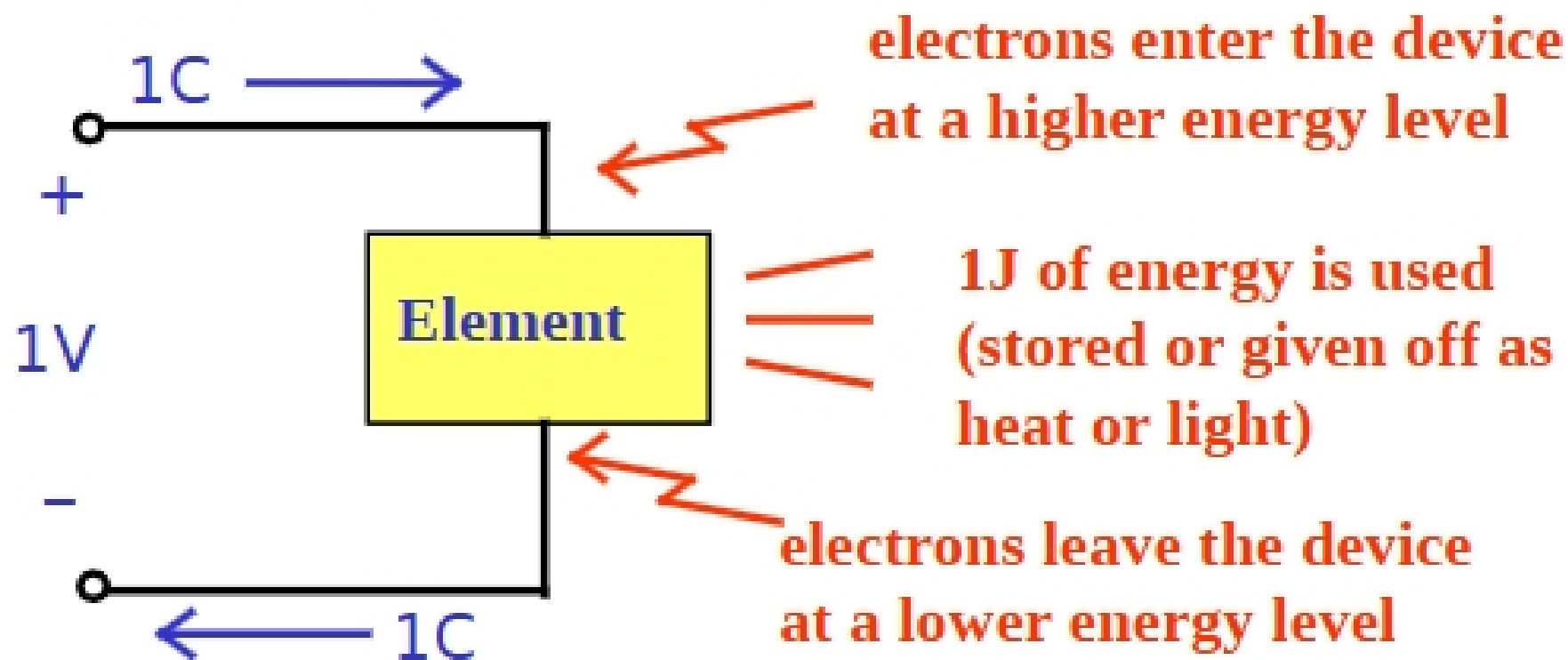

Voltage is sometimes referred to as an “electrical pressure” which forces charge through a circuit.

Water pipe analogy: Sometimes an analogy is made between an electric circuit and a water system. This may help to give a more intuitive feel to terms like charge, current, and voltage.

Electrical System	Water System